

Sixnet® Series ST-IPm-8460 SixTRAK IPm™ RTU/Controller

Hardware Guide | January 2025
LP1106 | Revision C



COPYRIGHT

© 2025 Red Lion Controls, Inc. All Rights Reserved. The terms Red Lion, the Red Lion logo, Sixnet, SixTRAK IPm and EtherTRAK are trademarks or registered trademarks of Red Lion Controls. All other marks are the property of their respective owners.

Corporate Headquarters
Red Lion Controls, Inc.
1750 5th Avenue
York, PA 17403

CONTACT INFORMATION:

AMERICAS

Inside US: +1 (877) 432-9908
Outside US: +1 (717) 767-6511
Hours: 8 am-6 pm Eastern Standard Time
(UTC/GMT -5 hours)

ASIA-PACIFIC

Shanghai, P.R. China: +86 21-6113-3688 x767
Hours: 9 am-6 pm China Standard Time
(UTC/GMT +8 hours)

EUROPE

Netherlands: +31 33-4723-225
France: +33 (0) 1 84 88 75 25
Germany: +49 (0) 1 89 5795-9421
UK: +44 (0) 20 3868 0909
Hours: 9 am-5 pm Central European Time
(UTC/GMT +1 hour)

Website: www.redlion.net

Support: support.redlion.net

Table of Contents

Preface	1
Disclaimer	1
Compliance Information	1
Part 15 of the Federal Communications Commission (FCC) - A Rules: Interference ...	1
Industry Canada	1
Environmental Impact Statement	1
Toxic Emissions	2
Trademark Acknowledgments	2
Document History and Related Publications	2
Additional Product Information	2
Warnings and Cautions	2
General Safety Cautions and Warnings	3
Electrical Safety Warnings	3
Environmental Safety Cautions and Warnings	4
Safety Information	4
Environmental	4
Electrical	4
Safety Standards	4
Chapter 1 Introduction and Specifications	7
Introduction	7
Software Tools	7
Sixnet I/O Tool Kit	7
Sixlog	7
Straton	7
ISaGRAF	7
SixTRAK IPm Industrial RTU Specifications	8
Ordering Information	9
Chapter 2 Installation and Assembly	11
Introduction	11
Contents of Package	11
Getting Started Installing Red Lion Hardware	11
DIN Rail Mounting and Removal	12
Panel Assembly	13
Chapter 3 Power and ST-Bus Wiring	15
Power Requirements	15
Current Requirements	15
DC Power Wiring	15
Redundant Power Inputs	15
SixTRAK IPm Power Connections	16
ST-Bus Wiring Guidelines	16

ST-Bus Capability	16
EtherTRAK-2 Wiring Guidelines	16
EtherTRAK-2 Guidelines	16
Network Topology	17
Ring Topology	17
Passthru Topology	17
Star Topology	18
Recommended Switches	18
Chapter 4 Communications Connections	19
Communication Ports	19
RS232 Ports A & B	19
RS485 Port C	19
RS232 Port D	20
Ethernet Port 1 (Primary)	20
Ethernet Port 2 with Built-in Switch	20
Chapter 5 Operation and Maintenance	21
Location Diagnostics	21
Status LED	21
SixTRAK IPm RTU/Controller Memory	21
Chapter 6 Red Lion Windows Software	23
Red Lion Software	23
Basic Configuration	23
Exporting I/O Definitions (optional, requires the SCS feature set)	23
Datalogging (optional, requires the SCS feature set)	23
IEC 61131 Programming (optional, requires the SCS feature set)	23
LINUX Capabilities (optional, requires the IPm Advanced feature set)	23
Service and Support Information	25
Service Information	25
For Your Convenience:	25
Product Support	25
LIMITED WARRANTY	26

Preface

Disclaimer

Portions of this document are intended solely as an outline of methodologies to be followed during the installation maintenance and operation of Sixnet® Series ST-IPm-8460 equipment. It is not intended as a step-by-step guide or a complete set of all procedures necessary and sufficient to complete all operations.

While every effort has been made to ensure that this document is complete and accurate at the time of release, the information that it contains is subject to change. Red Lion Controls, Inc is not responsible for any additions to or alterations of the original document. Industrial networks vary widely in their configurations, topologies, and traffic conditions. This document is intended as a general guide only. It has not been tested for all possible applications, and it may not be complete or accurate for some situations.

Users of this document are urged to heed warnings and cautions summarized at the front of the document, such as electrical hazard warnings.

Compliance Information

It is recommended that the owner of this equipment determine and ensure conformance with any specific and applicable local regulations.

Part 15 of the Federal Communications Commission (FCC) - A Rules: Interference

Every effort has been made to ensure that this equipment is designed to comply with the limits for a Class A digital device, as described in the FCC Rules.

This product complies with Part 15 of the FCC-A Rules.

Operation is subject to the following conditions:

1. This device may not cause harmful interference.
2. This device must accept any interference received, including interference that may cause undesired operation.

This equipment has been tested and found to comply with the limits for a Class A digital device, pursuant to Part 15 of the FCC Rules. These limits are designed to provide reasonable protection against harmful interference in a residential installation. This equipment generates, uses, and can radiate radio frequency energy and, if not installed and used in accordance with the instructions, may cause harmful interference to radio communications. Operation of this device in a residential area is likely to cause harmful interference in which case the user will be required to correct the interference at their own expense.

Industry Canada

This Class A digital apparatus meets all requirements of the Canadian Interference Causing Equipment Regulations. Operation is subject to the following two conditions; (1) this device may not cause harmful interference, and (2) this device must accept any interference received, including interference that may cause undesired operation.

Cet appareillage numérique de la classe A répond à toutes les exigences de l'interférence canadienne causant des règlements d'équipement. L'opération est sujette aux deux conditions suivantes: (1) ce dispositif peut ne pas causer l'interférence nocive, et (2) ce dispositif doit accepter n'importe quelle interférence reçue, y compris l'interférence qui peut causer l'opération peu désirée.

Environmental Impact Statement

Red Lion equipment contains no hazardous materials as defined by the United States Environmental Protection Agency (USEPA). Red Lion recommends that all failed product be returned to Red Lion for failure analysis and proper disposal.

Toxic Emissions

Red Lion equipment releases no toxic emissions.

Trademark Acknowledgments

Red Lion Controls acknowledges and recognizes ownership of the following trademarked terms used in this document.

Microsoft® and Windows® are registered trademarks of Microsoft Corporation in the United States and/or other countries.

Ethernet is a registered trademark of Xerox Corporation.

Tera Term is a registered trademark of T. Teranishi.

All other marks are the property of their respective owners.

Document History and Related Publications

The hard copy and electronic media versions of this document are revised only at major releases and therefore, may not always contain the latest product information. Tech Notes and/or product addendums will be provided as needed between major releases to describe any new information or document changes.

The latest online version of this document can be accessed through the Red Lion website at

www.redlion.net/support/documentation.

Additional Product Information

Additional product information can be obtained by contacting the local sales representative or Red Lion through the contact numbers and/or support website address listed on the inside of the front cover.

Warnings and Cautions

Warnings apply to situations where personal injury or death may result.

Cautions apply to where reduced function or damage to equipment may result.

These products should not be used to replace proper safety interlocking. No software-based device (or any other solid-state device) should ever be designed to be responsible for the maintenance of consequential equipment or personnel safety. In particular, Red Lion disclaims any responsibility for damages, either direct or consequential, that result from the use of this equipment in any application.

All power, input and output (I/O) wiring must be in accordance with Class I, Division 2 wiring methods and in accordance with the authority having jurisdiction.

Ces produits ne doivent pas être utilisés pour remplacer le verrouillage de sécurité approprié. Aucun dispositif basé sur un logiciel (ou tout autre dispositif à l'état solide) devraient jamais être conçus pour être responsable de l'entretien de l'équipement consécutifs ou la sécurité du personnel. En particulier, Red Lion décline toute responsabilité pour les dommages, directs ou indirects, résultant de l'utilisation de cet équipement dans n'importe quelle application.

Tout courant, câblage entrée et sortie (I / O) doit être conforme aux méthodes de câblage à la Classe I, Division 2 et conformément à l'autorité compétente.

General Safety Cautions and Warnings



CAUTION: If the Sixnet series equipment is used in the manner not specified by Red Lion, the protection provided by the equipment may be impaired.

ATTENTION: Si l' Sixnet série équipement est utilisé d'une manière non spécifiée par Red Lion, la protection fournie par l'équipement peut être compromise.



CAUTION: Do not perform any services on the unit unless qualified to do so. Do not substitute unauthorized parts or make unauthorized modifications to the unit.

ATTENTION: Ne pas effectuer de services sur l'appareil s'il n'est pas qualifié pour le faire. Ne pas substituer pièces non autorisées ou de modifications non autorisées de l'appareil.



CAUTION: Do not operate the equipment in a manner not specified by this manual.

ATTENTION: Ne pas faire fonctionner l'équipement d'une manière non spécifiée par ce manuel.



WARNING: Install only in accordance with Local and National Codes of authorities having jurisdiction.

ALERTE: Installer uniquement, conformément aux codes locaux et nationaux des autorités ayant compétence.

Electrical Safety Warnings



WARNING: Do not work on equipment or cables during periods of lightning activity.

ALERTE: Ne pas travailler sur le matériel ou les câbles pendant les périodes d'activité de la foudre.



WARNING: Properly ground the unit before connecting anything else to the unit. Units not properly grounded may result in a safety risk and could be hazardous and may void the warranty. See the grounding technique section of this Hardware Guide for proper ways to ground the unit.

ALERTE: Correctement à la terre de l'unité avant tout raccordement à l'unité. Unités pas correctement mise à la terre peut entraîner un risque de sécurité et pourraient être dangereux et peut annuler la garantie. Voir la section technique de mise à la terre de ce mode d'emploi des moyens appropriés à la masse de l'appareil.



WARNING: Do not operate the unit with the end plates removed, as this could create a shock or fire hazard.

ALERTE: Ne pas faire fonctionner l'unité avec les plaques d'extrémité retiré, ce qui pourrait créer une décharge électrique ou un incendie.



CAUTION: Observe proper DC Voltage polarity when installing power input cables. Reversing voltage polarity can cause permanent damage to the unit and voids the warranty.

ATTENTION: Respecter la polarité correcte de tension DC lors de l'installation des câbles d'alimentation d'entrée. Inversion de polarité de tension peut causer des dommages permanents à l'appareil et annule la garantie.

Environmental Safety Cautions and Warnings



CAUTION: This equipment is suitable for use in Class I, Division 2, Groups A, B, C, and D or non-hazardous locations only.

ATTENTION: Cet équipement est adapté pour une utilisation dans la classe I, Division 2, Groupes A, B, C et D ou non dangereux endroits seulement.



WARNING: Explosion Hazard – Substitution of components may impair suitability for Class I, Division 2.

ALERTE: Risque d'explosion - Remplacement d'un composant peut empêcher la conformité de Classe I, Division 2.



WARNING: Explosion Hazard - When in hazardous locations, disconnect power before replacing or wiring modules.

ALERTE: Risque d'explosion - Ne débranchez pas l'équipement à moins que l'alimentation ait été coupée ou que l'environnement est connu pour être non dangereux.



WARNING: Explosion Hazard – Do not connect or disconnect any connections while circuit is live unless area is known to be non-hazardous.

ALERTE: Risque d'explosion - Ne pas brancher ou débrancher les connexions lorsque le circuit est sous tension sauf si la zone est connue pour être non dangereux.

Safety Information

Environmental

Pollution degree: 2 (Per IEC 61010-1)

Electrical

Properly ground the unit before connecting anything else to it. If the equipment is used in a manner “not” specified by Red Lion, the protection provided by the equipment may be impaired.

Overvoltage category: II (Per IEC 61010-1)

Safety Standards

This unit meets the standards listed below, plus others.

Note: Some ratings may be pending on newer models. Contact Red Lion for the latest information.



Electrical safety:

CE per Low Voltage Directive and IEC 61010-1

UL recognition per UL508

CSA per C22.2/142



Markings:

Direct Current: 10-30 VDC (minimum/maximum)



Protective Conductor Terminal



See warnings below.

Install the controller in accordance with local and national electrical codes.

Installer le contrôleur conformément aux codes électriques locaux et nationaux.

Lightning Danger: Do not work on equipment during periods of lightning activity.

Danger lié à la foudre : Ne pas travailler sur l'équipement pendant les périodes d'activité de la foudre.

Do not connect a telephone line into one of the Ethernet RJ45 connectors.

Ne connectez pas de ligne téléphonique sur l'un des connecteurs Ethernet RJ45.





EMC (emissions and immunity):
CE per the EMC directive, EN 55022 or EN 61000-6-2/4



FCC part 15 and ICES 003; Class A. See FCC statement on previous page.



Marine, maritime and offshore:

These devices, when installed in an appropriately IP rated enclosure, comply with the ABS standards which are similar to DNV No. 2.4 and equivalent to Lloyds. See warning below.



For marine and maritime compliance, do not install this product within 5 meters of a standard or a steering magnetic compass.



WEEE compliance:

These devices comply with the WEEE directive. Do not throw away these devices in the standard trash. Contact Red Lion regarding proper disposal.



RoHS

RoHS compliance:

These devices comply with the RoHS directive and are consider lead and other hazardous substance free.



Hazardous Locations:

UL per ISA12.12.01 (Class I, Div. 2), Groups A,B,C,D (UL File # 317425)
CSA per C22.2/213 (Class 1, Div. 2), Groups A,B,C,D (cUL File # E317425)



ATEX per IEC 60079-0 and IEC 60079-7, Zone 2

Chapter 1 Introduction and Specifications

Introduction

The products covered by this manual are designed for use in industrial control and data acquisition systems. Refer to the Red Lion Electronic catalog and the individual technical documents for complete features and benefits. This manual covers the aspects of hardware installation and maintenance. For software features and capabilities, please refer to Red Lion's Electronic help System accessible from within the Sixnet I/O Tool Kit software and the virtual helpdesk on www.redlion.net.

A typical Red Lion station consists of an AC to DC power supply, a Red Lion HMI, Sixnet Series RTU/Controller, and EtherTRAK®-2 I/O modules. The I/O modules can be interfaced via Ethernet (EtherTRAK-2 dual Ethernet I/O modules), RS485 (EtherTRAK-2 dual Ethernet I/O modules), or the ST-BUS (Legacy SixTRAK I/O modules; supported for backward compatibility). Almost any combination of these components along with third party hardware and software can be used to make a system.

Software Tools

Red Lion supplies the "mission-oriented" tools you need for every step of your project from the initial specification, through startup, and years of trouble free operation. Configuration information flows between Red Lion Windows®, saving you time (you don't have to enter data multiple times) and dramatically reducing data entry errors. Refer to the online help in the Sixnet I/O Tool Kit for complete details.

Sixnet I/O Tool Kit

The Sixnet I/O Tool Kit is a configuration, calibration and maintenance tool for Red Lion hardware. Use the I/O Tool Kit to configure I/O features, perform channel-by-channel calibrations in meaningful engineering units, and perform live diagnostics at each station. Refer to the electronic help for details.

Here are the optional Feature Sets for the Sixnet I/O Tool Kit:

- **SCS (Scalable Control System) features:** Includes importing, tag exporting, I/O transfers and advanced load options. The SCS option is required to develop ISaGRAF programs, using the ISaGRAF Workbench.
- **Data logging:** Includes Sixlog data logging including automatic host and client transfers.
- **IPm™ Advanced feature:** Gain access to LINUX-visible features in SixTRAK IPm RTU/Controller, including file loading and advanced diagnostics. A library of functions to access the IPm I/O registers and other services is supplied with this enhanced license.

Sixlog

Sixlog is data logging software for Red Lion Sixnet Series IPm RTU/Controller, controllers, and RTUs. Data is logged into protected memory in the unit. Then Sixlog uploads the data files and saves them into ASCII format files that are easy to import into databases, spreadsheets and other Windows applications. Access the Sixlog functions from within the Sixnet I/O Tool Kit.

Straton

The Straton Workbench allows you to write IEC 61131 Control Programs for a Red Lion SixTRAK IPm RTU/Controller. Five IEC 61131 languages are supported (FBD, LD, ST, SFC, IL). The Straton Workbench may be downloaded from www.redlion.net. Within the Electronic help are extensive help topics and several tutorials.

ISaGRAF

The ISaGRAF Workbench allows you to write an IEC 61131 control program for a Red Lion SixTRAK IPm RTU/Controller. All 5 of the IEC 61131 languages are supported, including Ladder Logic and Function Blocks.

SixTRAK IPm Industrial RTU Specifications

Table 1.1 SixTRAK IPm Industrial RTU Specifications

Performance Specifications	<p>Processor: Industrial PPC (32-bit) Dynamic Memory (RAM): 512 MB (478 MB available) Program Memory (Flash): 512 MB (272 MB for application data and programs) Data Logging Memory (RAM): 8 MB (Battery backed) Data Logging: Sixnet SixLog or Red Lion Workbench IEC 61131 Programming: Red Lion Workbench (Sixnet ISaGRAF is supported for backward compatibility)</p>
Power Input	<p>Input Voltage: 10-30 VDC Steady Input Current: 150 mA @ 24 V (6.2 W max.) Inrush: 3.0 A / 60 μs @ 24 VDC BTU/HR: 12.29</p>
Switch Properties	<p>Operation: Unmanaged Number of MAC Addresses: 2 IEEE Compliance: 802.3u, 802.3x Protocols: TCP/IP, ARP, UDP, IGMP, DHCP, Modbus UDP/TCP, Sixnet UDR, Modbus ASCII/RTU, DNP3.0 and IEC 60870-101/104 Latency (typical): 10 Mbps: 16 μs, 100 Mbps: 5 μs Switching Method: Store-and-Forward Maximum Throughput: 90 Mbps (Network 2) MDIX Auto Cable Sensing Auto Sensing Speed and Flow Control MTBF: >820,000 hours per MIL-HNDBK-217F2</p>
Connectors	<p>Ethernet Ports Independent Networks with Unique MAC & IP Addresses Network 1 Port: One (1) shielded 10/100Base-T(X) port Network 2 Ports: Five (5) shielded 10/100Base-T(X) ports</p> <p>Serial Ports Supports speeds up to 115,200 baud RS-232 (Port A): RJ45 (TD, RD, CTS, RTS, CD, DTR, DSR, GND) RS-232 (Port B): RJ45 (TD, RD, CTS, RTS, CD, DTR, DSR, GND) RS-485 (Port C): Screw block (485+, 485-, GND) 2-wire half-duplex half-duplex, isolated 1,500 Vrms RS-232 (Port D): Screw block (TD, RD, RTS, CTS, GND) isolated 1,500 Vrms USB Port: Type B for diagnostics only</p>
Network Media	<p>10BaseT: >Cat3 cable 100BaseTX: >Cat5 cable</p>
Recommended Wiring Clearance	<p>Front: 3" (7.62 cm) Top: 2.5" (6.35 cm)</p>
Environmental	<p>Operating Temperature Range: -40 °C to 70 °C Storage Temperature: -40 °C to 85 °C Operating Humidity: 10% to 95% (non-condensing) Operating Altitude: 0 to 2,000 ft. Shock: IEC60068-2-6; Half Sine, 31 G, 11 ms duration Vibration: IEC60068-2-27; 9-200 Hz 2 G, 200-500 Hz 1.5 G</p>

Certification & Compliance	<p>Hazardous Locations: ISA12.12.01, CSA C22.2/213, Class 1, Division 2 Groups A, B, C, D ABS Type Approval for Shipboard Applications DNV Type Approved Electrical Safety: UL 508, CSA C22.2/142, IEC61010-1, CE EMI Emissions: FCC part 15, ICES-003, Class A, EN61000-6-4, CE EMC Immunity: EN61000-6-2, CE Flammability: UL 94V-0 materials</p>
ATEX (Zone 2)	<p>Protection string: Ex II 3 G Ex ec IIC T4 X Ambient temperature range: $-20\text{ }^{\circ}\text{C} \leq T_{\text{amb}} \leq 65\text{ }^{\circ}\text{C}$ Use field wiring with insulation rated to at least 105 °C Standards evaluated for ATEX: IEC 60079-0 Edition 7.0, IEC 60079-7 Edition 5.1 The equipment shall be installed in an enclosure that provides a degree of protection not less than IP54 in accordance with EN/IEC 60079-7 and used in an environment of not more than Pollution Degree 2 in accordance with EN/IEC60664-1 when applied in Zone 2 environments. The enclosure must be accessible only by the use of a tool.</p>
Mechanical	<p>Case Dimensions: Height: 3.17" (8.05 cm) Width: 4.75" (12.07 cm) Depth: 3.00" (7.62 cm) Weight: 0.75 lbs (0.34 kg) Mount: DIN rail 35 mm or flat panel mount</p>

Ordering Information

The Sixnet Series ST-IPm-8460 model part numbers and network applications are presented below.

PART NUMBER	DESCRIPTION	STATIC RAM	DYNAMIC RAM	FLASH MEMORY
ST-IPM-8460	Industrial RTU	8 MB	512 MB	512 MB

Chapter 2 Installation and Assembly

Introduction

This section contains the information and procedures necessary to unpack, inspect, install and connect the Sixnet Series ST-IPm-8460 equipment.

Contents of Package

The shipping package should contain the items listed below in undamaged condition. If the package contents are damaged, contact your carrier and file a damage claim with them.

- 1 ST-IPm-8460 unit
- 1 RJ45-DB9-KIT which includes 2 unwired adapters and 1 RJ45-DB9F-IPM
- 1 Quick Start Guide

Getting Started Installing Red Lion Hardware

Following these steps will make installation and start-up of your unit easier.

1. **Mount the Hardware:** Refer to "DIN Rail Mounting and Removal" for information on installing the Red Lion Hardware.
2. **Install ST-BUS or Communication Wiring to I/O Modules:** Make ST-BUS wiring connections to any legacy SixTRAK I/O modules. Refer to a following section for ST-BUS wiring guidelines. Make the necessary communication connections to any EtherTRAK-2 I/O modules.
3. **Connect Power and I/O Wiring to the Modules:** Connect AC power to the Red Lion or user supplied power supply. Make DC power connections from the power supply to the Red Lion components. Make field wiring connections to the Sixnet I/O modules and any peripheral equipment. Refer to the appropriate user manuals for I/O connection details. (refer to the "SixTRAK IPm Power Connections" diagram)
4. **Install Communication Cabling:** The unit covered by this manual comes with communication accessories. Snap the pre-wired RJ45 to DB9 adapter to the RJ45 patch cord (not supplied). Connect this cable between one of the serial RS232 ports (RJ45 connector) on your SixTRAK IPM RTU/Controller and a serial RS232 port (DB9 connector) on your PC. (refer to "Communication Ports")
5. **Fabricate and install RS232 and RS485 cables** as needed to connect to other devices. If you are using Ethernet units, install the correct cabling and peripherals. Refer to the documentation for your Ethernet communication devices for details. (refer to "Communication Ports")
6. **Apply Power:** Power up the Red Lion component and related peripherals. Observe the status LED on each unit. Typically a solid ON indicates proper operation. A blinking LED may indicate that the unit needs to be configured. Refer to the appropriate Red Lion manual for details. (refer to "Status LED")
7. **Configure Using the Sixnet I/O Tool Kit:** Use the Sixnet I/O Tool Kit to create a hardware configuration for each Red Lion station. Use RS232 or Ethernet to communicate to the RTU/Controller via the Tool kit. The default station number (slave address) used for Sixnet UDR and Modbus Protocols is one. The default IP address of network 1 is 10.1.0.1. Refer to the electronic help in the I/O Tool Kit for details. (refer to "Red Lion Software")
8. **Test the Hardware:** Use the Test I/O window in the I/O Tool Kit program to verify proper I/O operation of all Red Lion stations. Refer to the I/O Tool Kit electronic help system. (refer to Chapter 6)
9. **Configure Your PC Software to Communicate with the Red Lion Station(s):** Refer to the software documentation.
10. **If You Have Difficulty:** If you experience startup trouble, visit our Knowledge Base for some troubleshooting tips. If you still need assistance, please contact Red Lion Technical Support.

DIN Rail Mounting and Removal

The Sixnet Series ST-IPm-8460 units can be snapped onto a standard DIN rail (EN50022) or screwed directly to a flat panel. Refer to Figure 2.1 to properly mount the ST-IPm-8460 unit.

Note: Allow enough room to route Ethernet copper or fiber optic cables.

Figure 2.1 Mounting and Removal Instructions

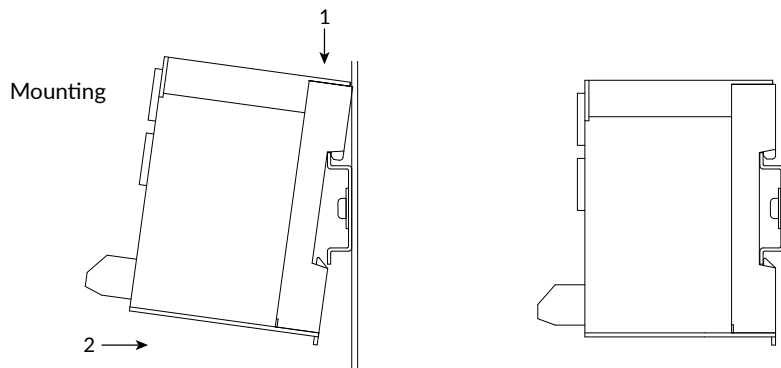

Recommended DIN rail mounting steps:

1. Hook the top of the unit over the DIN rail.
2. Push the bottom of the unit towards the DIN rail until it snaps into place.

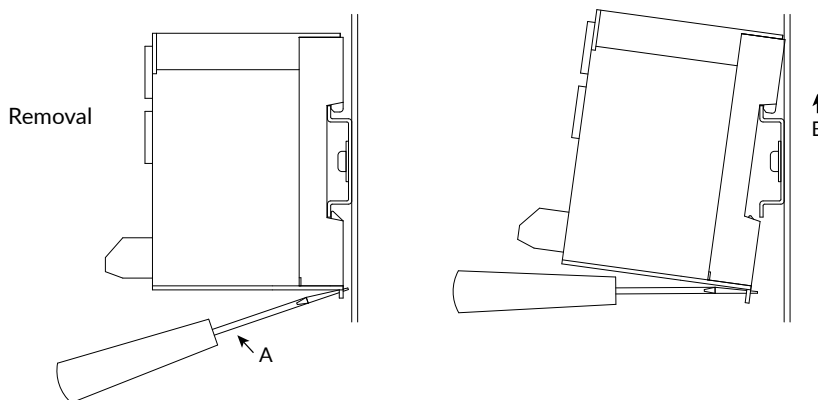

Recommended DIN rail removal steps:

- A. Insert screwdriver into DIN clip and pry until the bottom of the unit releases from the DIN rail.
- B. Unhook the top of the unit and remove it from the DIN rail.

Panel Assembly

Most Red Lion components snap onto DIN rail strips fastened to a sub panel. The figure below (Figure 2.2) shows a sample panel with DIN rail strips and wire duct attached. Recommended DIN rail spacing is 8 inches. This spacing allows room for wire duct to be installed without obstructing field wiring installation.

The Red Lion components are typically installed against one another, but space may be left between modules to accommodate other DIN rail mounted components such as terminal blocks and fuse holders. End clamps are recommended to restrict side-to-side movement.

Red Lion components can be installed in any orientation and order on your panel.

Figure 2.2 Sample Layout for a 36" x 30" Enclosure:

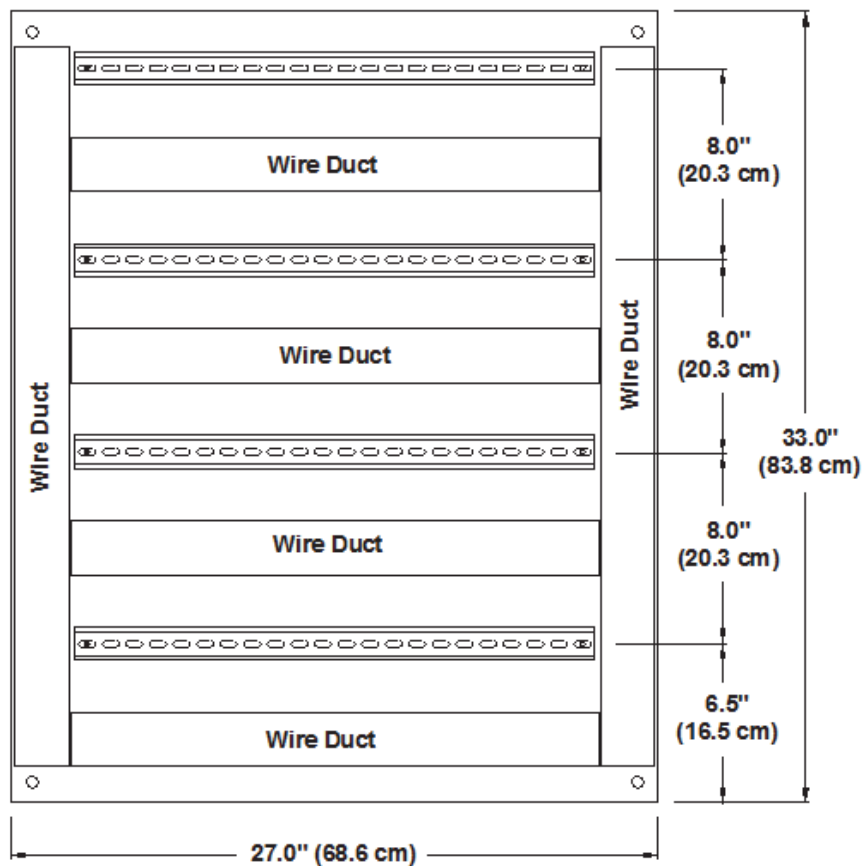
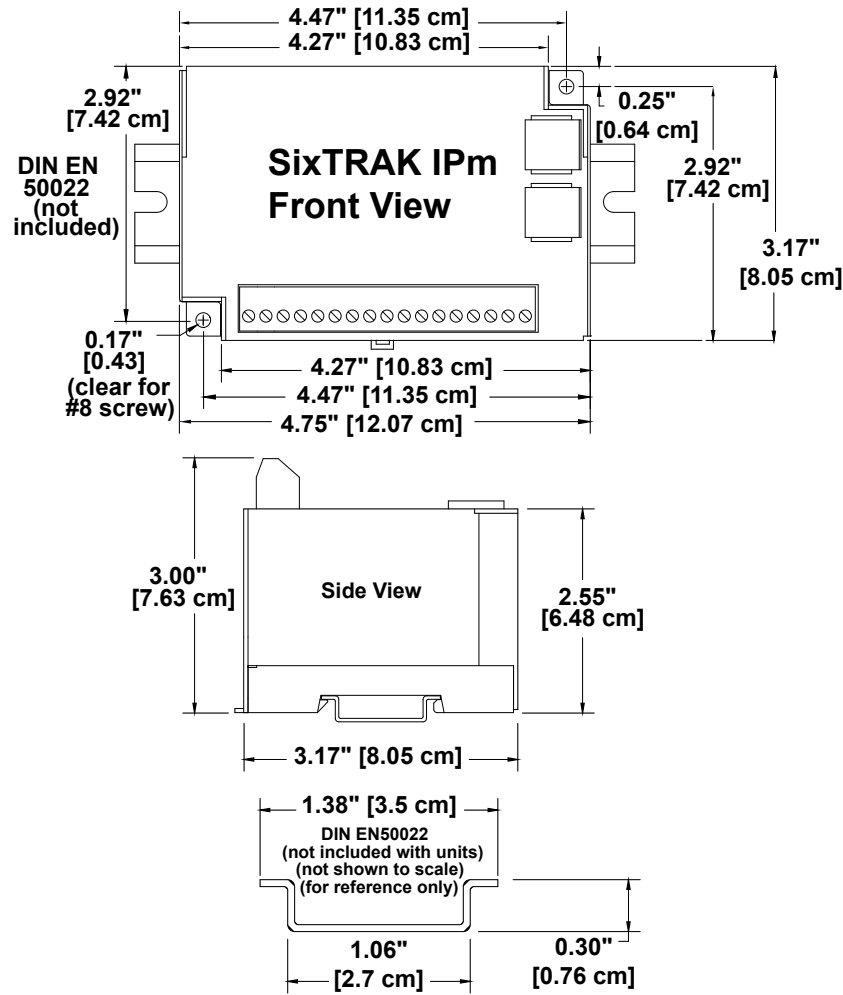

Figure 2.3 SixTRAK IPm RTU/Controller Dimensions:



Chapter 3 Power and ST-Bus Wiring

Power Requirements

Red Lion SixTRAK IPm RTU/Controller accepts a user DC power source of 10 to 30 VDC or a 24 VDC power from a Red Lion power supply. Although not required, Red Lion has the following power supplies:

- 24 VDC power supply @ 30 W (NTPS-24-1-3)
- 24 VDC power supply @ 72 W (NTPS-24-3)
- 24 VDC power supply @ 120 W (NTPS-24-5)

Current Requirements

To calculate the current requirements, add the wattage required for the Red Lion SixTRAK IPm RTU/Controller, and modules in use. Then divide the total wattage by the DC power source voltage. Then add any current needed for user instrumentation loops.

DC Power Wiring

All Red Lion units and user instrumentation loops may be powered from a single DC source. The user DC power source must be between 10 to 30 volts.

Wire Gauge Capacity of terminal plug: 12 to 28 AWG (3.31 TO 0.081 mm²) copper wire

Torque: 4.4 inch-lbs (0.5 N-m)

Strip insulation back on conductor: 0.25" to 0.27"

Redundant Power Inputs

The Red Lion SixTRAK IPm RTU/Controller has redundant power + input terminals. (There is one common power - terminal.) This allows you to connect two separate power supplies. If one fails then the other will take over powering your hardware. The SixTRAK IPm RTU/Controller can also have redundant power inputs but requires an externally wired diode. See figure below.

Note: In the SixTRAK IPm RTU/Controller, the ST C (+) and ST D (-) of the SixTRAK ST-BUS are internally connected to only the primary power input (terminals 2 and 4). Therefore, when running on only auxiliary power (terminals 3 and 4) there will be no power on terminals 16 and 17 (ST C and ST D). If redundant power is desired for the ST-BUS, it is recommended that the auxiliary power + be connected to terminal 16 through an external diode. The diode should be appropriately sized (current rating) for the number of legacy SixTRAK I/O modules being powered.

SixTRAK IPm Power Connections

Figure 3.1. Power Connections

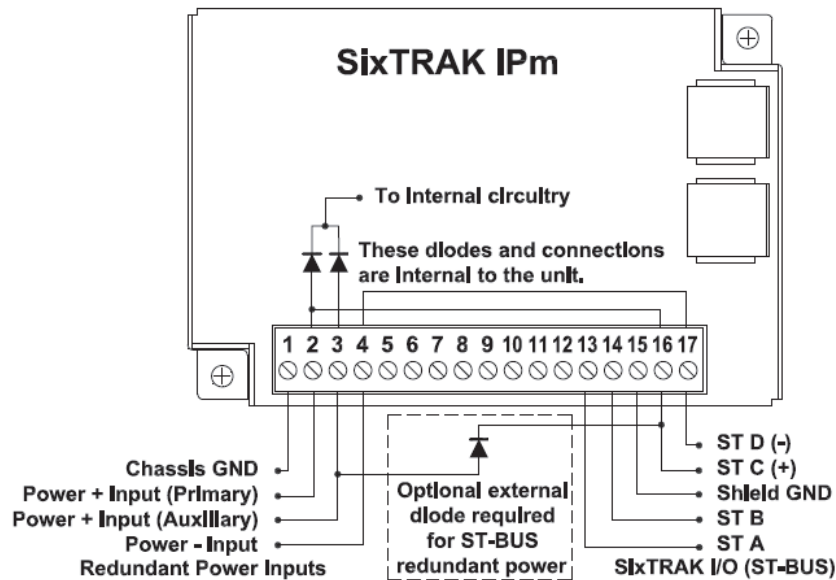

ST-Bus Wiring Guidelines

ST-Bus wiring connects the legacy SixTRAK I/O modules and expanders to the SixTRAK IPm RTU/Controller. Follow the upcoming guidelines for reliable performance.

ST-Bus Capability

- Max. modules or expanders connected directly to SixTRAK IPm RTU/Controller 10
- Max. modules connected to expander output 20 (any mix)
- Required cable type: any with 2 individually shielded pairs, 22 AWG min.
- Recommended cables: Alpha 2466C, Belden 8723, Carol C1352
- Max. cabling off each SixTRAK IPm RTU/Controller or expander 25 ft.

EtherTRAK-2 Wiring Guidelines

Connection to Dual Network I/O modules is standard 802.3 Ethernet. Best performance is seen when following the guidelines set out in that standard.

EtherTRAK-2 Guidelines

The specifications below are application guidelines to get the best performance from the SixTRAK IPm RTU/Controller. Depending on the specifics of the application these numbers can be tweaked. Factors that can affect performance are scan time, network, protocol and load from other programs running in the RTU.

- Maximum number of 3rd party stations and I/O modules per RTU: 128
- Ring Network limit (Switches and I/O modules): <50 per ring for best performance
- Passthru network limit (Switches and I/O modules): <25 for best results
- Minimum recommended cable quality: Cat 5
- Maximum length of Ethernet cable (per hop): 100 meters
- Maximum number of 3rd party stations and I/O modules at 10ms poll time: 16
- Maximum number of 3rd party stations and I/O modules at 100ms poll time: 50
- Poll time is not exact. Please allow for variance of poll time by up to 30% depending on application details.

Please contact Technical Support for more information.

Network Topology

Connecting the EtherTRAK-2 I/O modules to the SixTRAK IPm RTU/Controller is typically done with one or combination of one or more network topologies. These topologies are ring, passthru and star. They are defined below.

Ring Topology

Connect a ring of I/O modules to the SixTRAK IPm RTU/Controller using a Red Lion Sixnet Monitored and Managed Series switches. The Ring network creates a reliable redundant ring capable of recovering very quickly. Multiple Rings may be connected to the SixTRAK IPm RTU/Controller through switches and can be connected to either Network 1 or Network 2. The EtherTRAK-2 I/O modules must be in Ring mode to use this network configuration.

Figure 3.4. Ring Topology

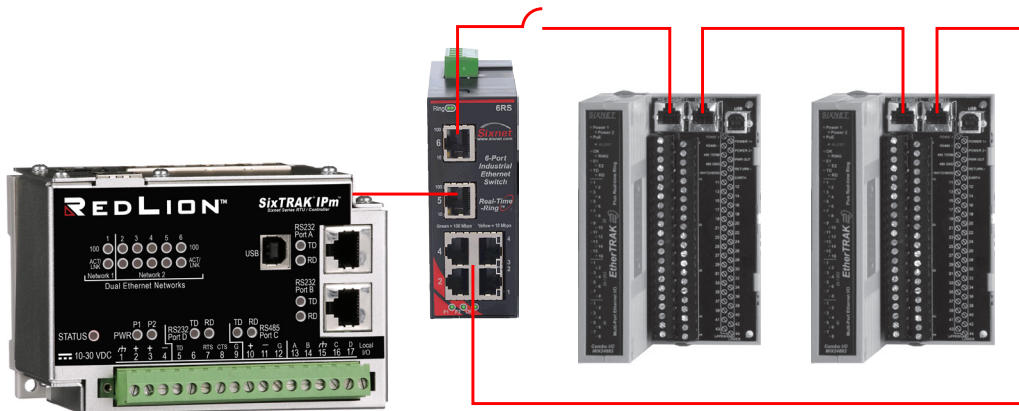

Passthru Topology

In this configuration no additional switches are needed. Simply daisy chain the EtherTRAK-2 I/O modules together and connect the first in the chain to the SixTRAK IPm RTU/Controller. Multiple chains may be connected to either Network 1 or Network 2. The EtherTRAK-2 I/O modules must be in PASsthru mode to use this network configuration.

Figure 3.5. Passthru Topology

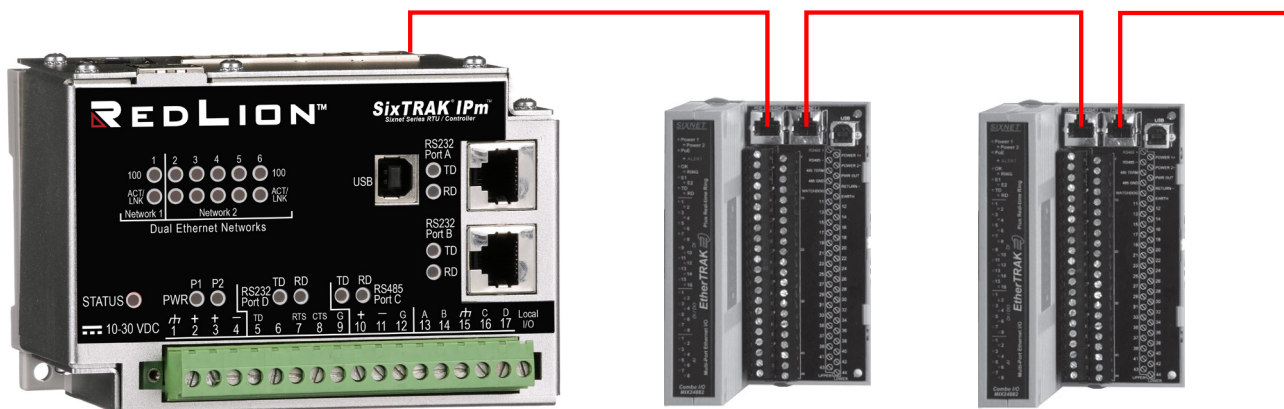

Star Topology

Using an external switch or the six Ethernet ports, connect one device to each port. The EtherTRAK-2 I/O modules must be in 2-Network/Star mode to use this network configuration.

Figure 3.2. Star Topology



Recommended Switches

The SixTRAK IPm RTU/Controller and EtherTRAK-2 I/O modules will work with all 802.3 switches. For applications using the Ring topology, Red Lion Sixnet Monitored and Managed switches are recommended.

- SLX-6RS-x
- SLX-xMS-x

Chapter 4 Communications Connections

Communication Ports

The Red Lion SixTRAK IPm RTU/Controller covered by this manual has various combinations of Ethernet and serial ports as shown in Table 4.1 below.

Table 4.1

PRODUCT	USB PORT	RS232 PORT A	RS232 PORT B	RS485 PORT C	RS232 PORT D	ETHERNET PORT 1	ETHERNET PORT 2	BUILT-IN SWITCH
ST-IPM-8460	X	X	X	X	X	X	X	X

RS232 Ports A & B

These ports are identical in connection and functionality. A RJ45 female connector is provided for each. The pin-outs follow the EIA/TIA-561 standard. A pre-wired DB9F to RJ45F adapter is included with these units. Use this adapter along with a RJ45 male to RJ45 male straight-thru wired patch cable (not included) to make a connection between a com port on your PC (DB9 male) and either Port A or B (RJ45 female). Refer to the Red Lion Electronic catalog for more information on connecting to other equipment.

RJ45 Pin Locations (for RS232 or Ethernet):

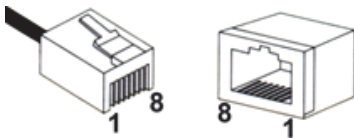

RS485 Port C

This port is found on all units. It provides a RS485 (2-wire, half duplex only) connection to Red Lion's EtherTRAK-2 I/O modules or other equipment. Three terminals (for signal gnd, 485+, and 485-) are provided. Generally, you connect + to + and - to - between units. However, since there is no standard for RS485 terminal designations you may need to connect + to - and - to + in some cases. No damage will result if you connect incorrectly. It is highly recommended that you tie the signal ground to an appropriate ground (if available) between all RS485 units. Make sure to use a good quality communication cable with three conductors (twisted is preferred) plus a shield. To prevent ground loops, the shield should be connected to chassis ground on only one end of any cable run.

Note: If you have existing wiring that has only two conductors and a shield, you can use the shield to connect the signal grounds between stations. This is not optimal (especially for long cable runs) but should work in most situations.

RS485 Termination: RS485 Termination is achieved through software configuration. In the port C configuration check the RS-485 Termination check box. Once the configuration is loaded to the SixTRAK IPm RTU/Controller the termination will take affect (150 ohm and a 0.1 μ F capacitor connected in series). It is recommended that both end stations of your RS485 network be terminated. Avoid terminating more than two stations. Refer to the EtherTRAK-2 I/O modules User Manual on how to terminate an EtherTRAK-2 module. For 3rd party devices, please refer to their user manual for termination instructions. Red Lion manuals can be found on the Red Lion website.

Bias Resistors: On a RS485 2-wire network, a pair of bias resistors (1K ohm typically) acting upon the transmit/receive wires may be required. If bias resistors are not present, the receive inputs on some RS485 devices may react to noise on the floating wires. The bias resistors will force the transmit/receive wires to a known (non-floating) state when none of the RS485 devices are transmitting data. Some RS485 devices have bias resistors built-in, and are enabled through DIP-switch or jumper settings. Make sure there is only one pair of bias resistors acting upon the network.

Note: If your RS485 network is made up exclusively of Red Lion devices, then these bias resistors are not necessary.

RS232 Port D

Five screw terminals (for TD, RD, RTS, CTS, and GND) are provided to make your connections.

Ethernet Port 1 (Primary)

This port is found on all units. It is a 10/100BaseTx auto-detecting and auto-crossover Ethernet port. This means it will auto-detect the speed, and work with either a straight-thru or cross-wired Ethernet cable. A standard shielded RJ45 connector is provided. See the figures below for the pin-outs. This port has a fixed unique MAC address. The IP address can be set with the Sixnet I/O Tool Kit software. Refer to the online help for details.

Ethernet Port 2 with Built-in Switch

This port is found on only the SixTRAK IPm RTU/Controller. It is internally tied to an industrial Ethernet switch. This provides four switched ports (standard shielded RJ45 connectors) to connect to peripheral equipment such as Red Lion's EtherTRAK-2 I/O modules. All are 10/100BaseTx auto-detecting and auto-crossover Ethernet ports. This means they will auto-detect the speed, and work with either a straight-thru or cross-wired Ethernet cable. This port has a fixed unique MAC address. The IP address can be set with the Sixnet I/O Tool Kit software. Refer to the online help for details.

Note: The primary Ethernet port is not internally tied to the internal Ethernet switch or the second Ethernet port. The first and second Ethernet ports act independently from each other. Refer to the Red Lion Electronic Help system for more details and usage tips.

Figure 4-1 SixTRAK IPm Communication Connections

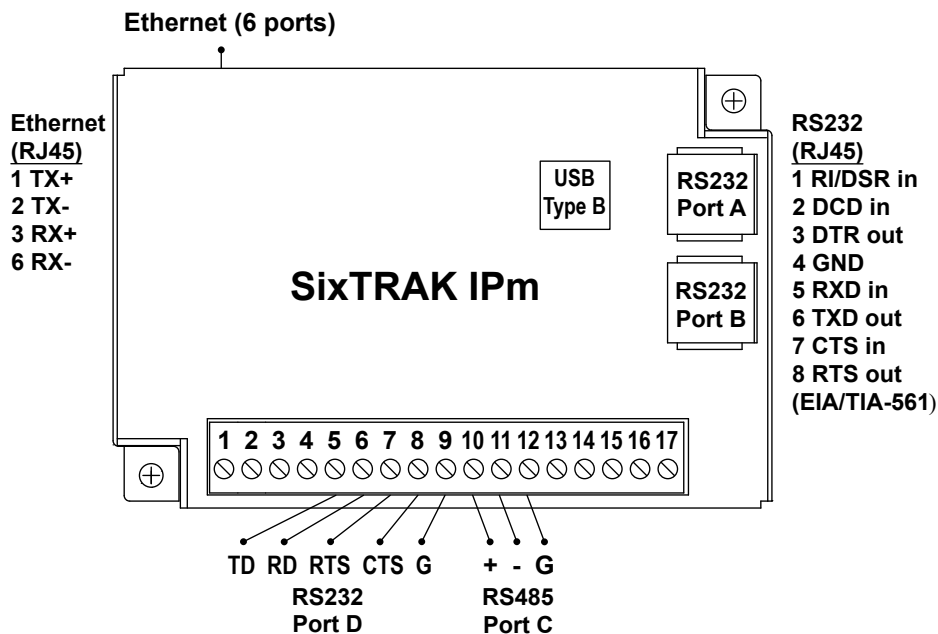

Chapter 5 Operation and Maintenance

Location Diagnostics

Local diagnostics can be performed through any available port while SixTRAK IPm RTU/Controller is responding to messages from the other port. Diagnostic software, such as the Sixnet® I/O Tool Kit, can be used to display the status of the I/O registers. Refer to the software's online help for details.

Status LED

The "Status" LED on the SixTRAK IPm RTU/Controller indicates its operational status:

ON: The SixTRAK IPm RTU/Controller is operating properly.

OFF: There is no power to the SixTRAK IPm RTU/Controller or service is required. Contact Red Lion technical support.

Fast blink: This may occur when then the SixTRAK IPm RTU/Controller is being reset, or firmware is to be downloaded from the I/O Tool Kit software.

Slow or periodic blink: This indicates that the internal watchdog has detected a problem. Try clearing the memory and reloading the project from the I/O Tool Kit.

Long ON Blink: Using controller redundancy a long on blink (90% ON 10% OFF) indicates that the controller is the primary controller.

Long OFF Blink: Using controller redundancy a long on blink (90% OFF 10% ON) indicates that controller is the backup controller.

Note: Please refer to the section on "Redundant Power Inputs".

SixTRAK IPm RTU/Controller Memory

These Red Lion controllers and RTUs have nonvolatile (battery-free) memory for storing configuration data from the I/O Tool Kit utility.

They also have battery-backed memory for storage of program variables and logged data. The battery is a rechargeable lithium cell that is kept fresh by the power circuitry in the SixTRAK IPm RTU/Controller. The memory retention period for an unpowered SixTRAK IPm RTU/Controller is at least 6 months at room temperature. The retention time will be shorter at higher temperatures. The life expectancy of the lithium battery is approximately 10 years or more. This battery is not field replaceable. To replace the battery, the SixTRAK IPm RTU/Controller must sent back to Red Lion.

Chapter 6 Red Lion Windows Software

Red Lion Software

Below is a quick overview on using the Sixnet I/O Tool Kit. It may be downloaded from www.redlion.net and for Level 1 (basic features) is free.

Note: An expanded version of this page has been provided as online help. To access the online help, click on the Getting Started icon in the I/O Tool Kit online help.

Basic Configuration

Run the Sixnet I/O Tool Kit program and create your panel layouts. Then configure operating parameters for each Red Lion component, including channel tag names. Link the SixTRAK I/O modules (if any) and load your configuration to the SixTRAK IPm RTU/Controller. Assign virtual I/O modules and I/O transfers for any EtherTRAK or RemoteTRAK® modules you wish to have the SixTRAK IPm RTU/Controller poll. Save this information to a project file. Using the Test I/O function, verify that you can read and write all your I/O.

Note: Set tag name restrictions in the Sixnet I/O Tool Kit program before creating tag names to ensure compatibility when exporting them for usage in other Windows applications.

Your Sixnet components are now ready to exchange I/O data with your Windows applications via DDE, OPC, or direct DLL calls. (Refer to the “How to Access Sixnet I/O From a Windows Application” topic in the Sixnet I/O Tool Kit online help.) If you will be running a Windows application, then continue with the following steps.

Exporting I/O Definitions (optional, requires the SCS feature set)

Some Windows applications, such as Straton/ISaGRAF, Citect and Intellution FIX, can import Sixnet tag names. If your Windows application supports this feature, run the Sixnet I/O Tool Kit and open your project file. Export your tag names to a file using the appropriate format.

Note: If you are exporting tag names for Straton/ISaGRAF, Citect or Intellution, you must create, or already have, a project to export tag data into

Datalogging (optional, requires the SCS feature set)

If you will be logging data in the SixTRAK IPm RTU/Controller, then create the appropriate datalog configuration(s) and load them into the unit. Refer to the Sixlog topics in the Sixnet I/O Tool Kit online help for details.

IEC 61131 Programming (optional, requires the SCS feature set)

If you are using the Straton/ISaGRAF IEC1131 programming software, refer to the Sixnet ISaGRAF on-line help for detailed instructions.

LINUX Capabilities (optional, requires the IPm Advanced feature set)

If you are using the advanced LINUX IPm capabilities, refer to the Sixnet I/O Tool Kit online help for detailed instructions.

Service and Support Information

Service Information

We sincerely hope that you never experience a problem with any of our products. If you do need service, call Red Lion at 1-877-432-9908 for Technical Support. A trained specialist will help you determine the source of the problem. Many problems are easily resolved with a single phone call. If it is necessary to return a unit to us, an RO (Repair Order) can be obtained on the Red Lion website.

Red Lion tracks the flow of returned material with our RO system to ensure speedy service. You must include this RO number on the outside of the box so that your return can be processed immediately.

Be sure to have your original purchase order number and date purchased available.

We suggest that you give us a repair purchase order number in case the repair is not covered under our warranty. You will not be billed if the repair is covered under warranty.

Please supply us with as many details about the problem as you can. The information you supply will be written on the RO form and supplied to the repair department before your unit arrives. This helps us to provide you with the best service, in the fastest manner. Repairs are completed as soon as possible. If you need a quicker turnaround, ship the unit to us by air freight. We give priority service to equipment that arrives by overnight delivery.

We apologize for any inconvenience that the need for repair may cause you. We hope that our rapid service meets your needs. If you have any suggestions to help us improve our service, please give us a call. We appreciate your ideas and will respond to them.

For Your Convenience:

Please fill in the following and keep this manual with your Red Lion system for future reference.

P.O. #: _____ Date Purchased: _____
Purchased From: _____
Serial Number: _____

Product Support

Technical Support:

Inside US: +1 (877) 432-9908
Outside US: +1 (717) 767-6511
Support: support.redlion.net
Hours: 8:00 am to 6:00 pm EST

Corporate Headquarters
Red Lion Controls
1750 5th Avenue
York, PA 17403
Website: www.redlion.net

LIMITED WARRANTY

(a) Red Lion Controls Inc. (the "Company") warrants that all Products shall be free from defects in materials and workmanship with normal use as specified in "Statement of Warranty Periods" (available at www.redlion.net). **EXCEPT FOR THE ABOVE- STATED WARRANTY, COMPANY MAKES NO WARRANTY WHATSOEVER WITH RESPECT TO THE PRODUCTS, INCLUDING ANY (A) WARRANTY OF MERCHANTABILITY; (B) WARRANTY OF FITNESS FOR A PARTICULAR PURPOSE; OR (C) WARRANTY AGAINST INFRINGEMENT OF INTELLECTUAL PROPERTY RIGHTS OF A THIRD PARTY; WHETHER EXPRESS OR IMPLIED BY LAW, COURSE OF DEALING, COURSE OF PERFORMANCE, USAGE OF TRADE OR OTHERWISE.** Customer shall be responsible for determining that a Product is suitable for Customer's use and that such use complies with any applicable local, state or federal law.

(b) The Company shall not be liable for a breach of the warranty set forth in paragraph (a) if (i) the defect is a result of Customer's failure to store, install, commission or maintain the Product according to specifications; (ii) Customer alters or repairs such Product without the prior written consent of Company.

(c) Subject to paragraph (b), with respect to any such Product during the Warranty Period, Company shall, in its sole discretion, either (i) repair or replace the Product; or (ii) credit or refund the price of Product provided that, if Company so requests, Customer shall, at Company's expense, return such Product to Company.

(d) **THE REMEDIES SET FORTH IN PARAGRAPH (c) SHALL BE THE CUSTOMER'S SOLE AND EXCLUSIVE REMEDY AND COMPANY'S ENTIRE LIABILITY FOR ANY BREACH OF THE LIMITED WARRANTY SET FORTH IN PARAGRAPH (a).**

BY INSTALLING THIS PRODUCT, YOU AGREE TO THE TERMS OF THIS WARRANTY, AS WELL AS ALL OTHER DISCLAIMERS AND WARRANTIES IN THIS DOCUMENT.