



PM-50 Analog Meter User Manual

LP1145 | August 2024

Firmware Version 1.4.1 or higher

COPYRIGHT

© 2024 Red Lion Controls, Inc. All Rights Reserved. The terms Red Lion and the Red Lion logo are registered trademarks of Red Lion Controls. All other marks are the property of their respective owners.

Corporate Headquarters
Red Lion Controls, Inc.
1750 5th Avenue
York, PA 17403

Table of Contents

Programming the PM-50

Programming Methods

Programming Wizard

Wi-Fi Setup and Remote Access:

 Wi-Fi Status

 How to connect to the PM-50 Wi-Fi Client

 How to connect to the PM-50 Wi-Fi Access Point

Push Notification

 How Push Notification Works

 Pre-Requisites For Push Notifications To Work:

 Wi-Fi Notes

 Update Firmware

Programming Wizard

 Initial Setup Wizard

 Quick Setup

Device Configuration

Main Display Icon Descriptions

Display Configuration

Network Configuration

Account Configuration

Signal Input Configuration

SP & Analog Configuration

Function Configuration

Totalizer Configuration

Modbus Configuration

Misc. Configuration

Home Screen

Supervisor/Quick Access Mode

Admin Mode

Supervisor Mode

Function Key Configurations

Home Screen

Admin Mode

Logged Out Mode (Supervisor)

Logged Out Mode (Admin)

Function Key Scenarios

Admin User Logged In On The Website

Admin User Logged In On Device:

Active State On Device And Website:

Page Timeout for Each Login

Serial RLC Protocol Communications

Command Chart

Command String Construction

Sending Numeric Data

Register Identification Chart

Command String Examples

Receiving Data From the Unit

Full Field Transmission (Address, Mnemonic, Numeric data)

Abbreviated Transmission (Numeric data only)

Unit Response Examples:

Auto/Manual Mode Register (MMR) ID: U

Analog Output Register (AOR) ID: W

Setpoint Output Register (SOR) ID: X

Hardware Setup

Specifications

Ordering Information

Accessories

DIMENSIONS In inches [mm]

INSTALLATION ENVIRONMENT

METER INSTALLATION

Adding Modules

To a 4.3 inch Host

Module Installation Variations for 4.3 Inch (1/8 DIN) PM-50

To a 3.5 inch Host

Wiring

Power Wiring

Service and Support Information

Service Information

Product Support

LIMITED WARRANTY

Programming the PM-50

Programming Methods

There are several methods to program a PM-50. On first power up, there is a default configuration that allows you to configure using the Initial Setup Wizard (also referred to as Programming Wizard). The Wizard has two options:

Quick Setup - This method allows you to manually configure the basic setup for Screen, Input, Output and Wi-Fi. After the configuration setup, you are directed to the HOME screen of the device.

Import Configuration - This method allows you to import a config.txt file from the microSD card. This file can be exported from another PM-50. Essentially cloning that device.

After the Initial Setup Wizard, additional touch screen programming or changes can be done by touching the Top right corner icon  called Configuration. You can also access the device configuration remotely. For remote access, you must first setup the Wi-Fi access. Once Wi-Fi is enabled, you can program remotely using web interface or mobile app (Android and iOS). It is also possible to import a config.txt file saved from another PM-50 using these remote means. An explanation of each of these methods follows.

Note: The device allows programming either using the touchscreen or remotely.

Programming Wizard

The Programming Wizard is the initial Device Setup Wizard which appears automatically:

- when the device boots for the first time or,
- when Factory Reset is enabled

The Programming Wizard can also be manually triggered by following these steps:

1. Login as the Admin user using the touchscreen
2. Go to  (Device) → Misc. Configuration → Factory Configuration → Enable Programming Wizard and set the switch to ON.
3. Click the Apply & Exit button, or continue on to the next pages and click the Apply button on the final page.
4. At the next power cycle or reboot, the Programming Wizard will start.
5. After exiting the Programming Wizard, it will automatically disable.

Note: Enable Programming Wizard cannot be enabled remotely using Wi-Fi through a web browser or through the Mobile app.

The complete Programming Wizard setup details can be found [here](#).

Wi-Fi Setup and Remote Access:

The Wi-Fi setup can be done during the Initial Setup Wizard, by importing the configuration from another device, or using the Quick Setup section.

Note: The Admin password must be enabled for Wi-Fi setup to be accessed.

1. If not using the Wizard or importing the configuration then, login to the device as the Admin user using the touchscreen.
2. Go to  [System Configuration](#) → [Network Configuration](#) → [Wi-Fi Configuration](#)
 - a. Set Enable Wi-Fi to ON and click the right navigation arrow.
 - b. If the Admin Password is configured already, then the next page will be Wi-Fi Connection Mode. Else “Set Admin Password” page will be loaded to configure the Admin password and proceed.
3. Set the Wi-Fi Connection Mode to Client or Access Point based on the remote connection requirement as follows:

Client Mode:

- In Client Mode, set Enable DHCP Client to ON and the connected running DHCP Server will assign the IP information. Otherwise, set Enable DHCP Client to OFF, then click on the right navigation arrow and setup the IP Address, Subnet Mask and Gateway.
- Configure the Access Point SSID and Password to connect to the running DHCP Server network.

Access Point:

- In Access Point mode, set Enable DHCP Server to ON if the user has to get the IP assigned automatically when they connect to the device’s Access Point.
- When Enable DHCP Server is ON, the user has to setup the IP Address, Subnet Mask, Gateway, Starting Address, and Ending Address.
- The Starting and Ending Addresses are used by the DHCP Server to assign a range of IP addresses allowed to connect to the PM-50.
- If Enable DHCP Server is OFF, then the user has to setup the IP Address, Subnet Mask and Gateway.
- Set the Encryption Mode based on the Access Point encryption requirement

4. Once the Wi-Fi Configuration setup is complete, turn Enable Modbus/TCP over Wi-Fi ON or OFF based on the necessary requirements. (This is not in the Wizard.)
5. Click the Apply button on the final page to configure the Wi-Fi settings.

Wi-Fi Status

The Menu bar should load with the Wi-Fi Icon after returning to the main display. There are two methods to check the status of the Wi-Fi:

1. Return to the configuration mode and click the Wi-Fi Icon in the menu bar. A page will load with the device IP details.
2. Go to  [Device](#) → [Misc. Configuration](#) → [About this Device](#) and click the right navigation arrow to go to the Network Configuration section.

<On Successful configuration>

IP Info: (AP) https://xxx.xxx.x.xx (your IP address)

Subnet Mask: 255.255.255.0

Gateway: 192.168.1.1

Wi-Fi Status: Cfg Success, AP 1 devices

<On connection failure with invalid SSID or password>

IP Info: (No Wi-Fi) 0.0.0.0

Wi-Fi Status: Cfg Success, Disconnected

<On configuration failure with Wi-Fi setup>

IP Info: (No Wi-Fi) 0.0.0.0

Wi-Fi Status: Configuration Failed

<On Wi-Fi setup is not initialized>

IP Info: (No Wi-Fi) 0.0.0.0

Wi-Fi Status: Cfg not initialized

The Network Configuration section provides the Wi-Fi configuration details with its IP Information or any connection issue.

Once the Wi-Fi Setup is successful with the IP assigned to the device and your PC/Mobile is connected, based on the “Wi-Fi communication mode”, follow the steps below to access the device configuration.

How to connect to the PM-50 Wi-Fi Client

1. Once the PM-50 is configured in Client mode successfully, the Wi-Fi icon will appear. Connect the PC/Mobile to the same network with the SSID and password.
2. To view the Wi-Fi configuration status with the IP details, click the Wi-Fi Icon in the menu bar while in Configuration mode, or go to  [Device](#) → [Misc. Configuration](#) → [About this Device](#). Then click the

right navigation arrow to access the Network Information section.

<On Successful configuration>

IP Info: (AP) https://xxx.xxx.x.xx (your IP address)

Subnet Mask: 255.255.255.0

Gateway: 192.168.1.1

Wi-Fi Status: Cfg Success, Connected

3. Open a web browser (Chrome, FireFox, Safari etc) or the Mobile App and enter “https://xxx.xxx.x.xx (your IP address)” to connect to the PM-50.

Note: You must be logged out of Configuration Mode on the device to log into configuration using Wi-Fi.

How to connect to the PM-50 Wi-Fi Access Point

1. Once the PM-50 has been configured in Access Point mode successfully, enable the Wi-Fi mode on your device and search for the SSID configured in the device.
2. Select the SSID and connect with the given password.
3. To check the connection status with the IP details from the PM-50, click the Wi-Fi Icon in the menu bar, or go to  [Device](#) → [Misc. Configuration](#) → [About this Device](#). Then click the right navigation arrow to go to the Network Information section to view the Wi-Fi configuration status.

<On Successful configuration>

IP Info: (AP) https://xxx.xxx.x.xx (your IP address)

Subnet Mask: 255.255.255.0

Gateway: 192.168.1.1

Wi-Fi Status: Cfg Success, AP 1 devices

4. Open a web browser (Chrome, FireFox, Safari etc) or the Mobile App and enter “https://xxx.xxx.x.xx (your IP address)” to connect to the PM-50.

Note: You must be logged out of Configuration Mode on the device to log into configuration using Wi-Fi.

Push Notification

A push notification is a message that pops up on a user's mobile device having the PM50 App installed and connected to the PM50. The notification is "pushed" from the server to the user even if the app is closed. The PM50 uses push notification to alert the user in case of changes in setpoint (digital output) status.

How Push Notification Works

To get push notification from the PM50, at least one setpoint annunciator needs to be enabled. By default, push notification is enabled on the PM50 and the mobile application. Once the mobile application is connected to the PM50, it will start receiving push notifications as soon as the PM50 sends one.

Push notification is sent when the setpoint state is changed on the PM50 and the annunciator is enabled in the setpoint configuration. The PM50 will send push notifications to only one mobile device. However, more than one PM50 can be connected to the same mobile device.

Note: Push notification is sent only to the last connected mobile device.

Push notification can be enabled or disabled only in the mobile application settings. The push notification title and description are static and cannot be modified. Screenshots of the push notifications received on iOS and Android mobile devices are shown below:

Android Screenshot

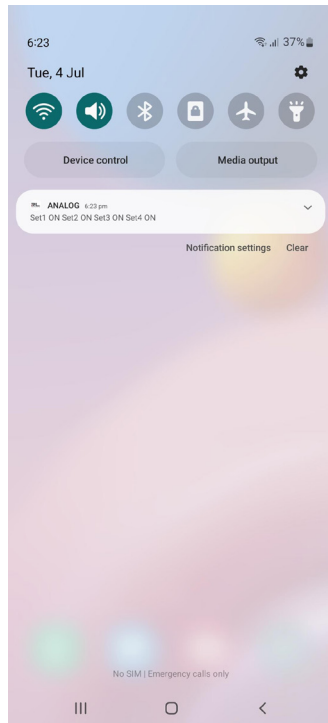

iOS Screenshot

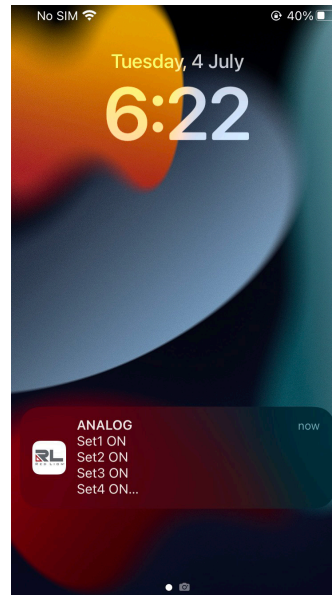

Pre-Requisites For Push Notifications To Work:

- a. The mobile device and the PM50 should always be connected to the internet
- b. Only one mobile device should be connected to the PM50.
- c. Android OS version should be greater than 9.0
- d. iOS version should be greater than 11.0

Note:

- a. Push notifications will be sent to the last connected mobile device. The previous connected device will be dropped without notification.
- b. Push notifications will be sent even when the App is closed.

- c. Push notifications will not work if the PM50 is configured in Access Point Mode.
- d. Push notification can be enabled or disabled only in the mobile application settings
- e. The content of the push notifications is static, only the IP address and setpoint number are dynamic parts.

Wi-Fi Notes

Presently, Wi-Fi is only for real time viewing and configuration of the PM-50. With DHCP Client enabled on, it is possible for the IP address to dynamically change by the server. There are only a few parameters that you cannot configure through Wi-Fi. There is a small delay to real time data update.

Update Firmware

The PM-50 allows you to update the firmware using the microSD card or remotely from a web browser. It is strongly suggested that the configuration in the PM-50 be saved to a config.txt file using a microSD card or through Wi-Fi before updating to a new firmware version.

Update Firmware Using MicroSD Card

The microSD card can be used to flash (install) new firmware onto the PM-50 by placing an image file (gpmcore.fwb) on the formatted microSD card. The microSD card should be 32 GB or smaller in size and formatted with the FAT16 or FAT32 format for the firmware update from microSD to work. Follow the steps below to flash new firmware onto the device.

1. Ensure the device is powered off and insert the microSD card loaded with the latest firmware into the microSD card slot in the device.
2. Power on the device and click the gear icon to login as the Admin User.
3. If you see the programming wizard, complete the initial setup or click the Exit button and complete the initial setup after the new firmware is installed.
4. Once the programming wizard updates are completed, login to the device with Admin user credentials.
5. Go to  [Device](#) → [Misc. Configuration](#) → [Firmware Upload](#)
6. The Firmware Upload page shows the microSD card status with the version of the firmware on it.

Note: If it shows “No SD Card”, “No Firmware in SD Card” or “Invalid FW in SD Card”, check the firmware name (gpmcore.fwb) and microSD Card size, then repeat steps 1 through 5.

7. Click the Upload button to upgrade to the new firmware.
 - The next page loads to show the Firmware Upload progress details. At the completion of the upload, the unit will proceed with reboot.
 - After the PM-50 reboots, The PM-50 will momentarily display the upgraded firmware version in the lower left screen area. The firmware version can also be verified at  [Device](#) → [Misc. Configuration](#) → [About this Device](#). User settings from the previous firmware should be retained.

Upgrade Firmware Remotely

The firmware of the PM-50 can be upgraded remotely from a web browser.

1. Login to the device remotely from a web browser.
2. Go to  [Device](#) → [Misc. Configuration](#) → [Firmware Upload](#)
3. Click the Select file button, select the firmware file (gpmcore.fwb) to upgrade to and click the [Upgrade](#) button.
4. A pop-up window warns that the firmware upgrade will reboot the device. Click on [Proceed](#) to start the firmware upgrade procedure and the PM-50 will show the upgrade status and then reboot. User settings from the previous firmware should be retained. You may lose Wi-Fi connection during reboot.
5. The PM-50 will momentarily display the upgraded firmware version in the lower left screen area.

Programming Wizard

The Programming Wizard is not available through Wi-Fi using a web browser or through the Mobile app.

Initial Setup Wizard

Select an Option to Continue
Quick Setup
Import Configuration
Exit

Quick Setup

Programming Wizard
Screen
Input
Output
Wi-Fi
Exit

From here, you have access to select the basic parameters you want to program without going through the entire configuration sequence.

For more detailed programming information for the menus, select the menu below:

[System](#)

[Device](#)

[Home Screen](#)

Items outlined in this color indicate programming wizard.

Programming Wizard Screen

Screen	
Screen Number	
1	<input checked="" type="radio"/>
2	<input type="radio"/>
3	<input type="radio"/>
4	<input type="radio"/>

Select which screen you would like to configure. Screen 1 shown.

Screen (1)	
Display Style	
None	<input checked="" type="radio"/>
Gauge	<input type="radio"/>
Temperature	<input type="radio"/>
Setpoint Status	<input type="radio"/>
Numeric	<input type="radio"/>
Max Min Total Monitor	<input type="radio"/>

If you select Setpoint Status for your display, the next menu you see will be:

Items outlined in this color indicate programming wizard.

Output Type

Setpoint 1

Setpoint 2

If you have a Dual or Quad Relay module installed, you will see additional Setpoints (up to 6). Select which setpoint statuses you want to see on the screen.

Apply settings

Save or cancel changes

Apply

Cancel

For the other Display Styles, you will see a combination of the following menus. Not all parameters are available for each of the different styles.

Signal Type

Analog Input



Totalizer



Display Units

units

Minimum Display Value

0

Items outlined in this color indicate programming wizard.

Maximum Display Value

200

Apply settings

Save or cancel changes

Apply

Cancel

Items outlined in this color indicate programming wizard.

Once back at the main Programming Wizard menu, you can choose to setup the Input, Output, Wi-Fi or Exit. All of the options are shown here. The options you see will depend on the selections you make as you step through the programming.

Programming Wizard Input

Device / Signal Input

Input Type

- Voltage
- Current
- Resistance
- RTD
- TC

Select the input range for your chosen input type.

Voltage Range

- +/- 200mV
- +/- 2V
- +/- 20V
- +/- 60V

Items outlined in this color indicate programming wizard.

Current Range

+/- 200 μ A



+/- 2mA



+/- 20mA



+/- 200mA



+/- 2A



Resistance Range

100 ohm



1000 ohm



10000 ohm



RTD Variant

r392



r672



r427



r385



Items outlined in this color indicate programming wizard.

TC Variant

tc-r	<input checked="" type="radio"/>
tc-S	<input checked="" type="radio"/>
tc-b	<input checked="" type="radio"/>
tc-n	<input checked="" type="radio"/>
tc-C	<input checked="" type="radio"/>
tc-t	<input checked="" type="radio"/>
tc-E	<input checked="" type="radio"/>
tc-J	<input checked="" type="radio"/>
tc-K	<input checked="" type="radio"/>

For RTD and TC Input Types Only:

Temperature Scale

Celsius	<input checked="" type="radio"/>
Fahrenheit	<input checked="" type="radio"/>

For TC Input Type only:

Enable Cold Junction Compensation

Off	<input checked="" type="radio"/>
On	<input checked="" type="radio"/>

Items outlined in this color indicate programming wizard.

Input Sample Rate

(/Second)

10



20



50



100



200



Display Units Decimal Point

0



0.0



0.00



0.000



0.0000



Scaling Points

Range: 2 to 10

2

Scaling Type A

Enter Values



Apply Signal



If Apply Signal method is chosen, buttons to read the Input and then save the value will follow each scaling point. Click [here](#) for an explanation of the difference between the two methods.

Items outlined in this color indicate programming wizard.

Decimal point position will change based on Input Range and Display Decimal point selections.

Scaling Point A1

Range: -1999.99 to 9999.99

0.00

Display Point A1

Range: -199999 to 999999

0

Scaling Point A2

Range: -1999.99 to 9999.99

100.00

Display Point A2

Range: -199999 to 999999

10000

Repeats for each successive pair.

Apply settings

Save or cancel changes

Apply

Cancel

Items outlined in this color indicate programming wizard.

Programming Wizard

Output

Device / Setpoint

Select Setpoint

Setpoint 1

Setpoint 2

Setpoints 3 to 6 will show based on the Dual Relay (Setpoint 3-4) or Quad Relay (Setpoint 3-6) module installed.

Device / Setpoint (1)

Setpoint Assignment

None



Relative



Absolute



Totalizer



If the Setpoint Assignment is None, then the next page is Apply settings. Explanation of the other parameters can be found [here](#).

Items outlined in this color indicate programming wizard.

Setpoint Action

None

Absolute Hi, Unbalanced Hysteresis

Absolute Low, Unbalanced Hysteresis

Absolute Hi, Balanced Hysteresis

Absolute Low, Balanced Hysteresis

Deviation Hi, Unbalanced Hysteresis

Deviation Low, Unbalanced Hysteresis

Outside Band, Unbalanced Hysteresis

Inside Band, Unbalanced Hysteresis

Totalizer Low, Unbalanced Hysteresis (Only shown when Setpoint

Totalizer High, Unbalanced Hysteresis Assignment selected for Totalizer)

Click [here](#) to go to the Alarm Action diagrams.

Setpoint Value for List A

Range: -199999 to 999999

Band / Deviation for List A

Range: -199999 to 999999

Items outlined in this color indicate programming wizard.

Hysteresis

Range: 0 to 65000

Setpoint Annunciator Type

Off

Normal

Flash

Reverse Phase

Annunciator Color

Orange

Red

Setpoint Active Color

Orange

Red

ON-Delay

Range: 0.0 to 3275.0 Sec

Items outlined in this color indicate programming wizard.

OFF-Delay

Range: 0.0 to 3275.0 Sec

0.0

Reset Action

Auto



Latch1



Latch2



Output Logic

Normal



Reverse



Apply settings

Save or cancel changes

Apply

Cancel

Items outlined in this color indicate programming wizard.

Programming Wizard
Wi-Fi

Network / **Wi-Fi**

Enable Wi-Fi



**Disables the Wi-Fi/Remote
operations**

Network / **Wi-Fi**

Enable Wi-Fi



**To use Wi-Fi, Admin
Password should be enabled**

Caution: There is no default password to unlock your unit if you forget the password you have entered. Make sure to place a copy of your password in a secure location to ensure you are not locked out. Once you hit Confirm, you will not be able to see or retrieve the password you entered.

System / **Account**

Set Admin Password

Enter New Password for Admin

Items outlined in this color indicate programming wizard.

System / Account

Set Admin Password

Enter New Password for Admin

Click to Re-enter and Confirm Password

System / Account

Set Admin Password

Re-Enter New Password for Admin

System / Account

Set Admin Password

Re-Enter New Password for Admin

Password Match. Confirm to proceed

Ignore

Confirm

Items outlined in this color indicate programming wizard.

Network / Wi-Fi

SSID

Network / Wi-Fi

Password

After setting your Wi-Fi password, the following menu will appear. After making your selection it will return you to the Programming Wizard main menu.

Apply settings

Save or cancel changes

Apply

Cancel

Items outlined in this color indicate programming wizard.

Import Configuration

Misc. / Import/Export

Import Config from SD Card

Filename

Import

Status:

The file name must be config.txt for a successful import.

When you click the import button, one of the following status messages will appear based on the microSD card:

- No SD Card detected - when the microSD card is not available in the slot, or the microSD card is an incompatible size or format
- File not found - If the microSD card is present, but the config.txt file does not exist
- Import successful, Rebooting - When the config.txt file is imported successfully, the device reboots to activate the configuration

Exit

If you select the Exit option from the Initial Setup Wizard Menu, the following menu appears.

Initial Setup Complete

Exit **Start Over**

Device Configuration

If you choose to skip the Quick Setup Programming Wizard, or did not enter a previous password, then the first time that you press the  icon you will see:

System / Account

Enable Admin Password

ON

Security Enabled

It is recommended to set an admin password to make the configuration secure. To recover your password in case you forget it, follow the Password Recovery instructions in Device Configuration.

System / Account

Set Admin Password

Enter New Password for Admin

System / Account

Set Admin Password

Enter New Password for Admin

Click to Re-enter and Confirm Password

System / Account

Set Admin Password

Re-Enter New Password for Admin

System / Account

Set Admin Password

Re-Enter New Password for Admin







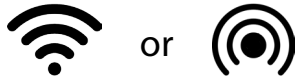
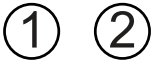

Password match. Confirm to proceed

Ignore

Confirm

Pressing the confirm button displays the main device configuration menu page. From here you can choose from the [System](#), [Device](#) or [Home Screen](#) icons to determine the section of the device you would like to configure.

Main Display Icon Descriptions

	<p>Top left company logo returns you to the main display.</p>
	<p>Wi-Fi icons - The left icon indicates connection to network, the right icon indicates access point mode is enabled. Press from Home screen to check Wi-Fi settings.</p>
	<p>Setpoint 1 & 2 Status. Status of other setpoints must be viewed using the setpoint widget.</p>
	<p>Help Icon - This takes you to the on-line manuals.</p>
	<p>Indicates when the Admin is logged in. The A icon can also indicate that the Configuration mode is not protected with a password. Note: If there is no user action/touch for 10 minutes, the device will automatically logout from Admin mode.</p>
	<p>Top right gear icon takes you into the System Configuration menu page.</p>
	<p>The Home icon returns the user to the main display. This will not log you out of Configuration mode.</p>
	<p>The Configuration icon allows you to access the Display, Network, and Account Configurations.</p>
	<p>The Device icon allows you to access the Signal Input, Setpoint, Function, Totalizer, Modbus, and Misc. Configurations.</p>
	<p>This icon allows you to access the Home Screen Configuration.</p>



System

Display Configuration

Brightness & Sleep Timer

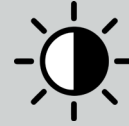

Update Display

Network Configuration

Wi-Fi



Set up Wireless Network

Account Configuration

User Access



User Account

Display Configuration

System / Display

Display Configuration

Display Brightness



Enable Sleep Timer



Default setting is OFF. This setting is the amount of time before the display goes dim if there is no screen touch.

Sleep Timer

Range: 1 to 3600 seconds

200

Display will dim after 200 Sec

Dark Theme

Power Save Mode



Power save mode when turned ON, will turn the background to Black. Off will turn the background to white.

Apply settings

Save or cancel changes

Apply

Cancel

Network Configuration

System / Network

Wi-Fi Configuration

Notification Configuration

Network / Wi-Fi

Enable Wi-Fi

ON

To use Wi-Fi, Admin Password should be enabled

When set to OFF, Wi-Fi and Remote operations are disabled. If switch is set to OFF, the next menu you see will be to apply or cancel changes. The below menus are enabled if the switch is set to ON.

Set Admin Password

Enter New Password for Admin

If you previously entered a password, the password parameters will be skipped. You must enter a new password to proceed.

Caution: There is no default password to unlock your unit if you forget the password you have entered.

Make sure to place a copy of your password in a secure location to ensure you are not locked out.

System / Account

Set Admin Password

Enter New Password for Admin

Click to Re-enter and Confirm Password

System / Account

Set Admin Password

Re-Enter New Password for Admin

Re-enter password to proceed.

System / Account

Set Admin Password

Re-Enter New Password for Admin

Password Match. Confirm to proceed

Ignore

Confirm

The password that you entered will be displayed. Pressing Ignore will send you back to enter a new admin password. Pressing Confirm takes you to the following menu. Once you hit Confirm, you will not be able to see or retrieve the password you entered.

Wi-Fi Connection Mode

Client



Access Point



If Client is selected the menus are:

Enable DHCP Client

ON

SSID

Password

Enable Modbus/TCP over Wi-Fi

OFF

Apply settings
Save or cancel changes

If Client is selected, and DHCP Client is OFF the menus are:

Enable DHCP Client



Dynamic Host Configuration Protocol is a network management protocol used to automate the process of configuring devices on IP networks. With it off, it allows the user to configure fixed parameters.

IP Address

Subnet Mask

Gateway

SSID

Password

Enable Modbus/TCP over Wi-Fi

OFF

Apply settings

Save or cancel changes

Apply

Cancel

If Access Point is selected the menus are:

Enable DHCP Client

OFF

IP Address

Subnet Mask

Gateway

SSID

Password

Encryption Mode

WPA PSK



WPA2 PSK



WPA + WPA2 PSK



The next 2 selections only appear if Enable DHCP Client is ON

Starting Address

Ending Address

Enable Modbus/TCP over Wi-Fi



Apply settings

Save or cancel changes

Apply

Cancel

Notification Configuration

Here we have two menus namely Device Name Configuration and Push Notification Configuration. Device Name Configuration refers to configuring the PM50 device name and Push Notification configuration refers to configuring the push notifications for the PM50 device.

Device Name Configuration

When you tap on Device Name Configuration, the first page displayed is the device name page. This name will be shown as the title of the push notification.

Network / **Device Name**

Device Name

Enter PM50 Device Name

This is the last page of the Device Name Configuration. Here we either click on Apply button which will save the configuration or click on the Cancel button to exit the configuration.

Apply settings

Save or cancel changes

Apply **Cancel**

The next menu is Push Notification Configuration. Here we can enable/disable the push notifications for the PM50 device. Also, we can enable push notifications for a specific setpoint.

Push Notification Configuration

The first page is for enabling the push notifications for the PM50 device. Here if we enable the user will receive push notifications and if it is disabled the user will stop receiving the push notifications.

Network / **Push Notify**

Enable Push Notification

Enable Push Notification for PM50 Device

ON

The next page is for selecting the setpoint for which we need to enable the push notifications.

Network / **Setpoint Notify Select**

Setpoint Number

Select Setpoint Number for Notification

Setpoint 1

Setpoint 2

Setpoint 3

Setpoint 4

The next page is for enabling the push notifications for the setpoint we selected on the previous page. The number in the round bracket represents the selected setpoint number.

Note: The push notification we enabled on the second page was global and the push notification we enabled now is for a specific setpoint.

Network / Push Setpoint Enb (1)

Setpoint Notification Status

Enable the setpoints you want notification from



The next page is for adding a description for the setpoint push notification. The content will be visible on the push notification popup when you receive the push notification from the device. The number in the round bracket represents the selected setpoint number.

Note: This description is specific to the setpoint we selected previously.

Network / Setpt Notify Message (1)

Notification Message

Enter notification Message for Push Notification

This is the last page of the configuration. Here we either click on Apply button which will save the configuration or click on the Cancel button which will exit the configuration pages and redirect to the page shown in the first screenshot. The number in the round bracket represents the selected setpoint number.

Apply settings

Save or cancel changes

Apply

Cancel

Note: Another crucial point to note is that configuration for only a single setpoint will be saved at a time.

Check list if Push notification is not received:

1. Check if the push notification is enabled on the device.

2. Check if internet is available to the device.
3. Check if in app setting notification option is enabled.

Account Configuration

User Access

User Account

If Password is set to OFF, remote operation (Wi-Fi) will be disabled and configurations will be insecure.

If the Admin password was enabled during Quick Start, the following menu will show Supervisor instead of Admin.

Note: The Admin password and Supervisor password MUST be different. Each password length should be 6-10 characters.

System / Account

Enable Admin Password

OFF

Password Recommended to
make the configuration secure.

Caution: There is no default password to unlock your unit if you forget the password you have entered. Make sure to place a copy of your password in a secure location to ensure you are not locked out.

System / Account

Enable Admin Password

ON

Security Enabled

Change Admin Password

Enter New Password for Admin

System / Account

Change Admin Password

Enter New Password for Admin

Click to Re-enter and Confirm Password

System / Account

Change Admin Password

Re-Enter New Password for Admin

Re-enter password to proceed.

System / Account

Change Admin Password

Re-Enter New Password for Admin

Password Match. Confirm to proceed

Ignore

Confirm

Login

User Type

Admin

Password

If the user has forgotten their password, they can press the Forgot Password button to reset the password and move on to the warning page. If the user selects the Forgot Password button, the warning message shown below will appear.

Forgot Password

 **Warning**

If you proceed, the existing password will become invalid.

If the user selects Cancel, then they will be returned to the Login page. If the user selects Proceed, a password recovery string will be displayed on the screen.

Note: If you proceed, the existing password will become invalid.

Password Recovery String

D7D4619MAR21001196969879

Please share this recovery string with the Red Lion tech-support team to generate One Time Password.

Email: support@redlion.net

Once the recovery string is generated, it will remain the same until the user generates a new string for the password. Once the recovery string is generated, the user needs to send a password recovery request email along with this string to support@redlion.net. Our tech support team will respond back with a new password.

AMERICAS

Hours: 8 am-6 pm Eastern Standard time
(UTC/GMT -5 hours)

ASIA-PACIFIC

Hours: 9 am-6 pm China Standard Time
(UTC/GMT +8 hours)

EUROPE

Hours: 9 am-5 pm Central European Time
(UTC/GMT +1 hour)

Modbus - read-only mode



This Modbus read only mode applies only to Modbus protocol and not RLC protocol. Setting this switch ON will let the user do Modbus reads only over the various interfaces (Wi-Fi, User RS485, RS232 and Ethernet modules). No writes are allowed if this read-only mode is turned ON.

Apply settings

Save or cancel changes

Apply

Cancel

Upon re-entry to System Account Menu, the screen now shows Supervisor instead of Admin. Setting a Supervisor password allows limited access to specific configuration values like setpoint value, reset, etc. Supervisor mode can only be accessed through a function key enabled for Supervisor.

System / Account

Enable Supervisor Password

OFF

Password Recommended to
make the configuration secure.

Note: You must be logged in to the PM50 as Admin to set up Supervisor mode. If the password for Supervisor is not set by an Admin, Supervisor mode is not enabled.

System / Account

Enable Supervisor Password

ON

Security Enabled

Set Supervisor Password

Enter New Password for Supervisor

System / Account

Set Supervisor Password

Enter New Password for Supervisor

Click to Re-enter and Confirm Password

System / Account

Set Supervisor Password

Re-Enter New Password for Supervisor

Re-enter password to proceed.

System / Account

Set Supervisor Password

Re-Enter New Password for Supervisor

Password Match. Confirm to proceed

Ignore Confirm

The password that you entered will be displayed. Pressing Ignore will send you back to enter a new admin password. Pressing Confirm takes you to the following menu. Once you hit Confirm, you will not be able to see or retrieve the password you entered.

System / Account

Enable Admin Password

ON

Change Password OFF

Security Enabled

Selecting Change Password to ON will allow you to change the Admin Password following the exact same sequence as above. This is then followed by Modbus settings and then the Apply settings box.

Apply settings

Save or cancel changes

Apply Cancel

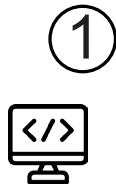

Device

Signal Input Configuration

Signal Input

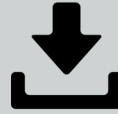

Setup Input parameters

SP & Analog Configuration

Setpoint & Analog (Analog is only available with Analog module attached.)

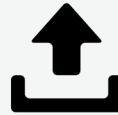

Setup SP & Analog parameters

Function Configuration

Function Key & User Input



Setup Function

Totalizer Configuration

Totalizer



Setup Totalizer (Integrator)

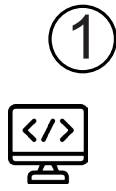

Device

Modbus Configuration

Modbus(ASCII/RTU/TCP) & RLC(ASCII)



Setup Wired Communication

Misc Configuration

Import/Export & Factory



Calibration, Firmware Update..

Signal Input Configuration

Device / Signal Input

Signal Input Configuration

Input Type

Voltage



Current



Resistance



RTD



TC



Select the input range for your chosen input type.

Voltage Range

+/- 200mV



+/- 2V



+/- 20V



+/- 60V



Current Range

+/- 200 μ A



+/- 2mA



+/- 20mA



+/- 200mA



+/- 2A



Resistance Range

100 ohm



1000 ohm



10000 ohm



RTD Variet

r392



r672



r427



r385



TC Variant

tc-r	<input checked="" type="radio"/>
tc-S	<input checked="" type="radio"/>
tc-b	<input checked="" type="radio"/>
tc-n	<input checked="" type="radio"/>
tc-C	<input checked="" type="radio"/>
tc-t	<input checked="" type="radio"/>
tc-E	<input checked="" type="radio"/>
tc-J	<input checked="" type="radio"/>
tc-K	<input checked="" type="radio"/>

For RTD and TC Input Types Only:

Temperature Scale

Celsius	<input checked="" type="radio"/>
Fahrenheit	<input checked="" type="radio"/>

For TC Input only.

Enable Cold Junction Compensation

Off	<input checked="" type="radio"/>
On	<input checked="" type="radio"/>

If using external compensation, set this parameter to off. In this case, use copper leads from the external compensation point to the unit.

Input Sample Rate
(/Second)

10	<input type="radio"/>
20	<input type="radio"/>
50	<input type="radio"/>
100	<input type="radio"/>
200	<input type="radio"/>

Select the ADC sample rate (per second). The selection does not affect the display update rate, however it does affect setpoint and analog output response time. The default factory setting is recommended for most applications. Selecting a fast update rate may cause the display to appear very unstable.

Display Update Rate
(/second)

1	<input type="radio"/>
2	<input type="radio"/>
5	<input type="radio"/>
10	<input type="radio"/>
20	<input type="radio"/>

This parameter configures the display update time only. It does not affect the response time of the setpoints nor the analog out.

Display Units Decimal Point

0
0.0
0.00
0.000
0.0000



Display Units Decimal Point selection affects Rounding Value, Offset Display, Display Point, setpoint values, band values and analog out scaling.

Rounding Value

0.01
0.02
0.05
0.10
0.20
0.50
1.00



Rounding selections other than one, cause the Input Display to 'round' to the nearest rounding increment selected (ie. rounding of '5' causes 122 to round to 120 and 123 to round to 125). Rounding starts at the least significant digit of the Input Display. Remaining parameter entries (scaling point values, setpoint values, etc.) are not automatically adjusted to this display rounding selection. Decimal point location is based on the Display Units Decimal point selection.

Offset Display

Range: -1999.99 to 9999.99

The display can be corrected with an offset value. This can be used to compensate for probe errors, errors due to variances in probe placement or adjusting the readout to a reference thermometer. It is also useful in weighting applications to tare the scale. This value is automatically updated after a Zero Display to show how far the display is offset. The new displayed value will be known as Relative. A value of zero will remove the affects of offset, and in this case the Relative and Absolute values will be the same.

Digital Filter

Range: 0.0 to 25.0 Seconds

The input filter setting is a time constant expressed in tenths of a second. The filter settles to 99% of the final display value within approximately 3 time constants. This is an Adaptive Digital Filter which is designed to steady the Input Display reading. A value of '0' disables filtering.

Filter Band

Range: 0.00 to 650.00

The digital filter will adapt to variations in the input signal. When the variation exceeds the input filter band value, the digital filter disengages. When the variation becomes less than the band value, the filter engages again. This allows for a stable readout, but permits the display to settle rapidly after a large process change. The value of the band is in display units, independent of the Display Decimal Point position. A band setting of '0' keeps the digital filter permanently engaged.

Scaling Points

Select: 2 to 10

2

For linear processes, only 2 scaling points are necessary. It is recommended that the 2 scaling points be at opposite ends of the input signal being used. The points do not have to be the selected Input Range limits. Display scaling will be linear between and continue past the entered points up to the limits of the selected Input Range limits. Each scaling point has a coordinated pair of Scaling Point and Display Point.

For non-linear processes, up to 10 scaling points may be used to provide a piece-wise linear approximation. (the greater the number of scaling points used, the greater the conformity accuracy.) The shown displayed value will be linear between the coordinated pairs of Scaling Points and Display Points that are sequential in configuration order. The displayed value will continue to be linear below the first Scaling Point and beyond the last Scaling Point to the limits of the selected Input Range.

Note: The device supports up to 40 scaling points when configured via microSD card. 1-10 scaling points can be configured from the device and scaling points 11 and up can be configured using misc. config import/export.

Scaling Type A

Enter Values



Apply Signal



If Scaling Point Input Values and corresponding Display Values are known, the Enter Values scaling style can be used. This allows scaling without the presence of the input signal. If Input Values have to be derived from the actual input signal source or simulator, the Apply Signal scaling style must be used.

If Apply Signal method is chosen, **Read Input** and **Save Input** buttons are shown. The previous entered value is displayed until Read Input is pressed and then the display will show the applied present value. Save Input will save that value. If you do not want to apply the value, press the right advance arrow and it will retain the previous entered value. Apply signal is only available through the PM-50 touchscreen. If the device is connected through Wi-Fi or any other communication, apply method is disabled.

Scaling Point A1

Range: -1999.99 to 9999.99

For Enter Value Scaling, enter the first known input value. For Apply Signal Scaling, apply the input signal that corresponds to the first Display Point. The decimal point is determined by the Input Range selection.

Display Point A1

Range: -1999.99 to 9999.99

Enter the first coordinating Display value to the first Scaling Point input value. The decimal point is determined by Display Units Decimal Point.

The Display Point values are used to calculate a displayed value of the input signal to a desired useful value. This value can be used for communication, setpoints and analog retransmission. This value is known as the Absolute or Gross Value and it includes the Offset value.

Scaling Point A2

Range: -1999.99 to 9999.99

For Enter Value Scaling, enter the second known input value. For Apply Signal Scaling, apply the input signal that corresponds to the second Display Point.

Display Point A2

Range: -1999.99 to 9999.99

100.00

Enter the second coordinating Display value to the second Scaling Point input value. The decimal point is determined by Display Units Decimal Point.

Repeats for each successive pair.

Enable Scale List B



When enabled, a second list of scaling points is active. Two lists or Types of scaling points are available. This allows for two different applications with the same PM-50. If a User Input or Function Key is configured and activated for Select Parameter List, then List B scaling will be used. The display will indicate which list is being used momentarily.

The following Type B parameters will only show if List B is on.

Scaling Type B

Enter Values



Apply Signal



Apply signal is not available if Wi-Fi is enabled.

Scaling Point B1

Range: -1999.99 to 9999.99

0.00

For Enter Value Scaling, enter the first known input value. For Apply Signal Scaling, apply the input signal that corresponds to the first Display Point. The decimal point is determined by the Input Range selection.

Display Point B1

Range: -1999.99 to 9999.99

0.00

Enter the first coordinating Display value to the first Scaling Point input value. The decimal point is determined by Display Units Decimal Point.

Scaling Point B2

Range: -1999.99 to 9999.99

For Enter Value Scaling, enter the second known input value. For Apply Signal Scaling, apply the input signal that corresponds to the second Display Point.

Display Point B2

Range: -1999.99 to 9999.99

Enter the second coordinating Display value to the second Scaling Point input value. The decimal point is determined by Display Units Decimal Point.

Repeats for each successive pair.

Show Min Max Capture parameter



Default setting is OFF.

Max Capture Assignment

Relative



Absolute



This function determines if the Max Capture will be the Relative or Absolute display value. The Relative is a net value that includes the Display Offset Value. The Absolute is a gross value (based on Scaling Point and Display Point entries) without the Display Offset Value.

Max Capture Duration

Range: 0.0 to 3275.0 Sec

When the Input Display Value is above the present MAX value for the entered duration time, the unit will capture that display value as the new MAX reading. A duration time helps to avoid false captures of sudden short spikes.

Min Capture Assignment

Relative

Absolute

This function determines if the Min Capture will be the Relative or Absolute display value. The Relative is a net value that includes the Display Offset Value. The Absolute is a gross value (based on Scaling Point and Display Point entries) without the Display Offset Value.

Min Capture Duration

Range: 0.0 to 3275.0 Sec

When the Input Display Value is below the present MIN value for the entered duration time, the unit will capture that display value as the new MIN reading. A duration time helps to avoid false captures of sudden short spikes.

Apply settings

Save or cancel changes

SP & Analog Configuration

Device / SP & Analog Configuration
Setpoint SSR Logic
Setpoint Configuration
Analog Configuration (If Analog Module is installed)

Setpoint SSR Logic

Device / SSR Logic
SSR Logic for Setpoint 1 and 2
Source
Sink

This setting only applies to Setpoints 1 and 2. Setting the SSR Logic for Source requires an external DC supply be connected per the wiring drawing shown in the Installation Guide.

Apply settings

Save or cancel changes

Apply

Cancel

Setpoint Configuration

Device / **Setpoint**
Select Setpoint

Setpoint 1

Setpoint 2

If Dual Relay Module is installed you will see 4 setpoint selections and if the Quad Relay Module is installed you will see 6 setpoint selections.

Device / **Setpoint (1)**
Setpoint Assignment

None

Relative

Absolute

Totalizer

Relative - Setpoint to trigger from the relative (net) input value. This value includes the Absolute value with the display offset value.

Absolute - Setpoint to trigger from the absolute (gross) input value. The absolute input value is based on the entered Scaling Point (input value) and Display Scaling calculation without the Offset Value.

Totalizer - Setpoint to trigger from the Totalizer input value.

Setpoint Action

None

Absolute Hi, Unbalanced Hysteresis

Absolute Low, Unbalanced Hysteresis

Absolute Hi, Balanced Hysteresis

Absolute Low, Balanced Hysteresis

Deviation Hi, Unbalanced Hysteresis

Deviation Low, Unbalanced Hysteresis

Outside Band, Unbalanced Hysteresis

Inside Band, Unbalanced Hysteresis

Totalizer Low, Unbalanced Hysteresis (Only when Setpoint Assignment set

Totalizer High, Unbalanced Hysteresis for Totalizer)

See Setpoint Alarm Figures for a visual detail of each action. The Setpoint Actions that pertain to the Total is only active when the Setpoint Assignment is set to Totalizer.

Totalizer low is an Absolute Hi alarm based on a setpoint value from the lower 6 digits of the Totalizer. Totalizer high is an Absolute Hi alarm based on a setpoint value from the upper 6 digits of a 9 digit Total.

Setpoint Alarm Figures

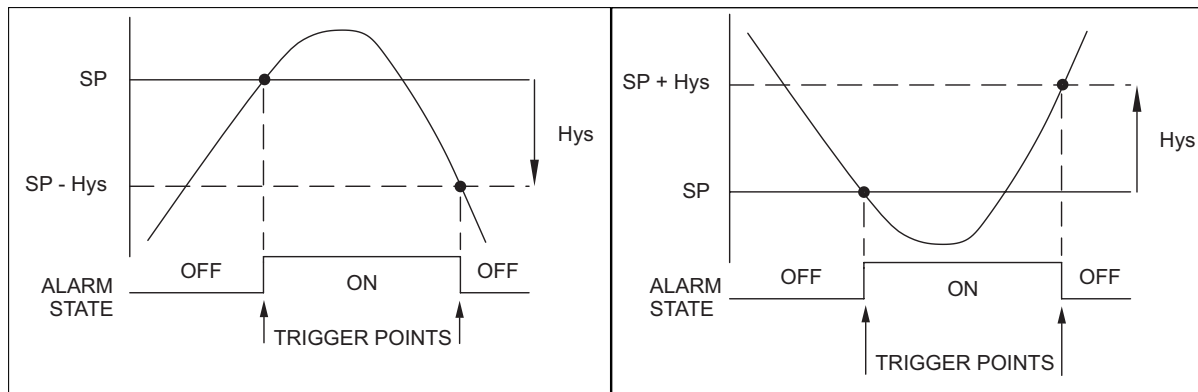

Absolute High Acting (Unbalanced Hys)
This is also for Totalizer alarms

Absolute Low Acting (Unbalanced Hys)

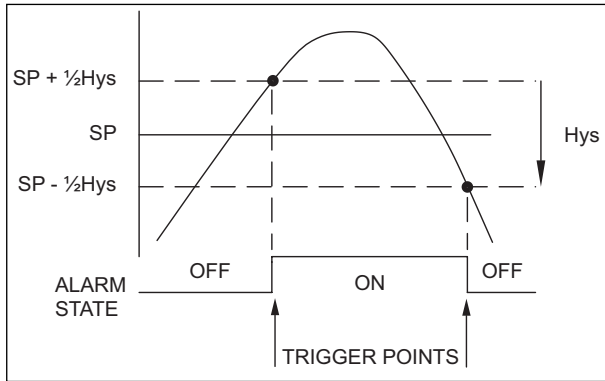

Absolute High Acting (Balanced Hys)

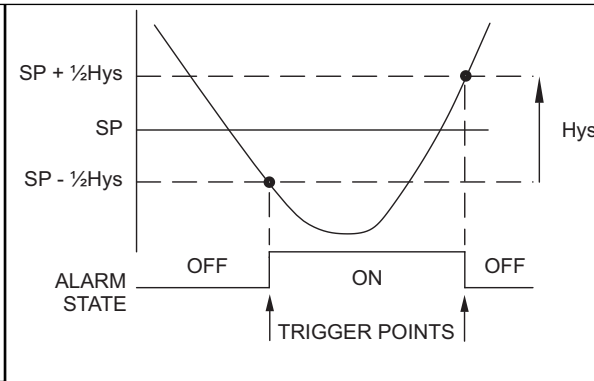

Absolute Low Acting (Balanced Hys)

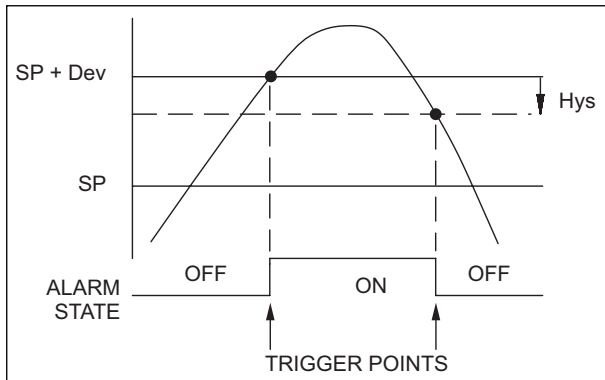

Deviation High Acting (Dev > 0)

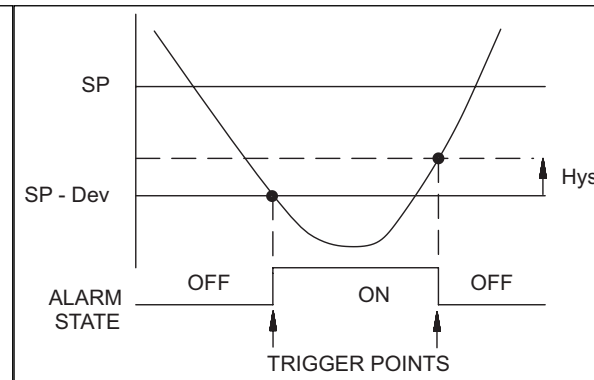

Deviation Low Acting (Dev > 0)

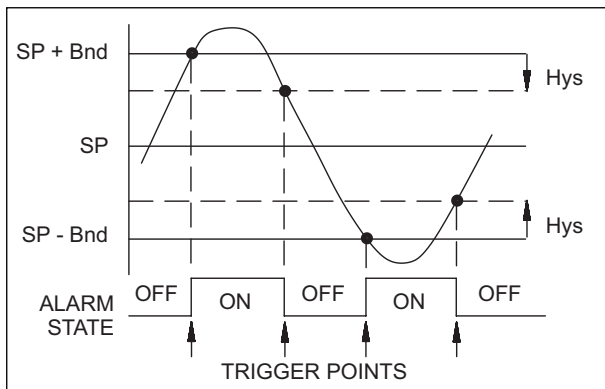

Band Outside Acting

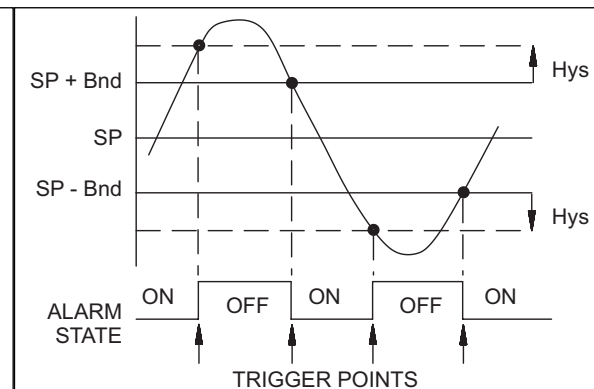

Band Inside Acting

Configure List A/B

List A Config



List B Config



Two lists of setpoint point and band values are available. If a User Input or Function Key is configured and activated for Select Parameter List, then List B scaling will be used. The display will momentarily indicate which list is being used. If List B is being used, then all configured setpoints will be changed to List B values. If a specific setpoint is to remain the same value, then for that setpoint the value must be configured the same for both A and B. All other setpoint parameters will be the same for both lists.

Setpoint Value for List A

Range: -1999.99 to 9999.99

100.00

Band / Deviation for List A

Range: -1999.99 to 9999.99

0.00

This parameter is only available in band and deviation setpoint actions. Enter desired setpoint band or deviation value. When the Setpoint Action is programmed for Band, this value can only be a positive value.

Hysteresis

Range: 0.00 to 650.00

0.02

Enter desired hysteresis value. See Setpoint Alarm Figures for visual explanation of how setpoint alarm actions (balanced and unbalanced) are affected by the hysteresis. When the setpoint is a control output, usually balanced hysteresis is used. For alarm applications, usually unbalanced hysteresis is used. For unbalanced hysteresis modes, the hysteresis functions on the low side for high acting setpoints and

functions on the high side for low acting setpoints. Note: Hysteresis eliminates output chatter at the switch point, while time delay can be used to prevent false triggering during process transient events.

Setpoint Annunciator Type

Off
Normal
Flash
Reverse Phase

Off - Disables display setpoint annunciators.

Normal - Displays the corresponding setpoint annunciators of "on" setpoint alarm outputs.

Flash - Flashes the corresponding setpoint annunciators of "on" setpoint alarm outputs.
This setting has precedence over normal.

Reverse - Displays the corresponding setpoint annunciators of "off" setpoint alarms outputs.

Setpoint Annunciator is the border around the display. If any setpoint is configured for a type other than Off and is in the corresponding listed active state, the border will be the Annunciator Color. Only if all setpoints configured for a type other than Off are **ALL** not in the corresponding listed active state, the border will be the color green. It is not possible to tell which individual setpoint is in the active state here.

Annunciator Color

Orange
Red

Annunciator Color sets the color of the display border when a setpoint is in the listed active state. Red shall have precedence over Orange.

Setpoint Active Color

Orange
Red

Setpoint Active Color is the color used in the Setpoint Status Widget and icons to show the active state of the configured setpoint individually. Clear is for not configured. Green is for not active. There are no flash or reverse selections. Red shall have precedence over Orange.

ON-Delay

Range: 0.0 to 3275.0 Sec

0.0

Enter the time value in seconds that the setpoint alarm is delayed from turning on after the trigger point is reached. A value of 0.0 allows the unit to update the setpoint alarm status per the response time listed in the Specifications. When the output logic is Reverse, this becomes off time delay. Any time accumulated at power-off resets during power-up.

OFF-Delay

Range: 0.0 to 3275.0 Sec

0.0

Enter the time value in seconds that the setpoint alarm is delayed from turning off after the trigger point is reached. A value of 0.0 allows the unit to update the setpoint alarm status per the response time listed in the Specifications. When the output logic is Reverse, this becomes on time delay. Any time accumulated at power-off resets during power-up.

Reset Action

Auto



Latch1



Latch2



Enter the reset action of the setpoint alarm output.

Auto = Automatic action; This action allows the setpoint alarm output to automatically reset off at the trigger points per the Setpoint Action shown in Setpoint Alarm Figures. The “on” setpoint alarm may be manually reset (off) immediately by a front panel function key or user input. The setpoint alarm remains reset off until the trigger point is crossed again.

Latch1 = Latch with immediate reset action; This action latches the setpoint alarm output on at the trigger point per the Setpoint Action shown in Setpoint Alarm Figures. Latch means that the setpoint alarm output can only be turned off by front panel function key or user input manual reset, serial reset command or unit power cycle. When the user input or function key is activated (momentary or maintained), the corresponding “on” setpoint alarm output is reset immediately and remains off until the trigger point is crossed again. (Previously latched setpoint alarms will be off if power up Display Value is lower than setpoint value.)

Latch2 = Latch with delay reset action; This action latches the setpoint alarm output on at the trigger point per the Setpoint Action shown in Setpoint Alarm Figures. Latch means that the setpoint alarm output can only be turned off by front panel function key or user input manual reset, serial reset command or unit power cycle. When the user input or function key is activated (momentary or maintained), the unit delays the event until the corresponding “on” setpoint alarm output crosses the trigger off point. (Previously latched setpoint alarms are off if power up Display Value is lower than setpoint value. During a power cycle, the unit erases a previous Latch 2 reset if it is not activated at power up.)

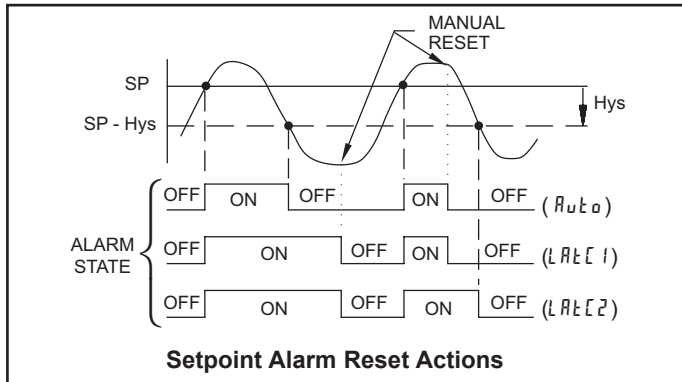

Output Logic

Normal

Reverse

Setpoint Standby Operation

No

Yes

When set for Yes, the alarm is disabled (after a power up) until the trigger point is crossed. Once the alarm is on, the alarm operates normally per the Setpoint Action and Reset Mode.

If Input Signal Type is set for RTD or TC, the following menu appears.

Probe Burn-out Action

Output Off

Output On

Apply settings

Save or cancel changes

Apply

Cancel

Repeat the above section for each setpoint to be used. Each setpoint corresponds to an appropriate output.

Analog Configuration

This menu is only available with the Analog Output Module installed.

Device / Analog	
Analog Output Type	
4 to 20 mA	<input checked="" type="radio"/>
0 to 20 mA	<input type="radio"/>
0 to 10 VDC	<input type="radio"/>
-10 to +10 VDC	<input type="radio"/>

Analog Output Assignment	
None	<input checked="" type="radio"/>
Relative	<input type="radio"/>
Absolute	<input type="radio"/>
Totalizer	<input type="radio"/>
Max	<input type="radio"/>
Min	<input type="radio"/>

Select the source that the analog output will retransmit.

Relative - Relative value (net) is the Absolute value including the Display Offset value.

Absolute - Absolute value (Gross) is based on the entered Scaling Point (input value) and Display Scaling calculation not including the Offset Value.

Totalizer - Totalizer is the Totalizer value.

Max - Max is the Maximum Display value.

Min - Min is the Minimum Display value.

Analog Low Scale

Range: -1999.99 to 9999.99

Enter the Analog Output Assignment display value that will generate the lowest output signal of the selected Analog Output Type.

Analog High Scale

Range: -1999.99 to 9999.99

Enter the Analog Output Assignment display value that will generate the highest output signal of the selected Analog Output Type.

Probe Burn-out Action

Low



High



This setting is only for TC and RTD inputs. In the event of a temperature probe failure, the analog output can be programmed to produce a low or high output signal.

Apply settings

Save or cancel changes

Apply**Cancel**

Function Configuration

Device / Function

Function Key Configuration

User Input Configuration

Function Key Configuration

Enable Function Key



The function keys can perform their function through Wi-Fi. To show or hide the function keys, press the bottom left arrow while in the Display mode.

Function Key

F1



F2



F3



F4



There are only two Function keys on the 3.5 inch PM-50.

Access	
Supervisor	<input checked="" type="radio"/>
All User	<input checked="" type="radio"/>

The Access option selects whether the Function Key is accessible in supervisor mode through use of a password, or to all users without a password.

Rename Key
<input type="text"/>

Rename Key lets you create your own 5 character label for the Function Key you are configuring.

Select Function

A function key can be assigned to perform more than one function at the same time. Momentary actions take place after the release of the key

If Supervisor is selected as the access option, the available functions are limited to:

- None
- Setpoint Value
- Reset
- Adjust Brightness

None	No function is performed if activated. This is the factory setting for all function keys.
Setpoint Value	The unit displays the current setpoint value of the active list and allows the operator to change that value.
Reset	As long as activated (maintained action). The function key turns yellow when active in the maintained mode. The programmed parameter resets to the present Input Display value. This can also deactivate setpoints. The parameter function then continues from that value. This selection functions independent of the selected display.

Tare Display	The Zero (Tare) Display provides a way to zero the Input Display value at various input levels, causing future Display readings to be offset. This function is useful in weighing applications where the container or material on the scale should not be included in the next measurement value. When activated (momentary action), the Display is set to zero. At the same time, the Display value (that was on the display before the Zero Display) is subtracted from the Display Offset Value and is automatically stored as the new Display Offset Value. If another Zero (tare) Display is performed, the display will again change to zero and the Display offset value will shift accordingly.
Display Absolute	This function will switch the Input Display between Relative and Absolute. The Relative is a net value that includes the Display Offset Value. The Input Display will normally show the Relative unless switched by this function. Regardless of the display selected, all unit functions continue to operate based on the selection made for that output. The Absolute is a gross value without the Display Offset Value. The Absolute display is selected as long as the function key is activated (maintained action). The function key turns yellow when active in the maintained mode. When the function key is pressed again, the input display switches back to Relative display. Absolute or Relative is momentarily displayed at transition to indicate which display is active.
Store Batch	The Input Display value is added (batched) to the Totalizer at transition to activate (momentary action). The Totalizer retains a running sum of each batch operation until the Totalizer is reset. When this function is selected, the normal operation of the Totalizer is overridden and only batched Input Display values accumulate in the Totalizer.
Adjust Brightness	When activated (momentary action), the display brightness changes to the next level.
Select Parameter List	Two lists of input scaling points and setpoint values (including band and deviation) are available. The display will momentarily indicate which list is active when the List B scaling is changed. Scaling List B must be enabled for this function to be performed. Scaling points can be disabled from changing to List B. However, this will always enable all configured setpoints to their List B values. If you do not want a value to change then you must make that setpoint List A and List B value the same.
Print Request	This Function Key issues a single block print through the serial port when activated, and the serial type is set to RLC Protocol. The data transmitted during a print request and the serial type is programmed in Modbus Configuration → RS485 Configuration → Communication Type → RLC Protocol .

If the Function Key is set to Reset, you then choose the parameter to reset. More than one parameter can be chosen to be reset at the same time.

Totalizer

Max Display

Min Display

Setpoint 1

Setpoint 2

} There can be up to 6 setpoints

Apply settings

Save or cancel changes

Apply

Cancel

Repeat the above section for each function key to be configured.

User Input Configuration

Device / User Input
SNK/SRC
User Input

Functions / SSR

Active Status

Sink

Source

Sink refers to active state when user voltage is low.
Source refers to active state when user voltage is high.

Apply settings
Save or cancel changes

Apply **Cancel**

User Input / Functions

Hardware Input

User Input 1



User Input 2



Function

The user input can be assigned to perform more than one function at the same time.

None	No function is performed if activated. This is the factory setting for all user inputs.
Reset	As long as activated (maintained action), the programmed parameter resets to the present Input Display value. This can also deactivate setpoints. The parameter function then continues from that value. This selection functions independent of the selected display.
Program Lockout	Configuration Mode is locked-out, as long as activated (maintained action). The password will not override this.
Tare Display	The Zero (Tare) Display provides a way to zero the Input Display value at various input levels, causing future Display readings to be offset. This function is useful in weighing applications where the container or material on the scale should not be included in the next measurement value. When activated (momentary action), the Display is set to zero. At the same time, the Display value (that was on the display before the Zero Display) is subtracted from the Display Offset Value and is automatically stored as the new Display Offset Value. If another Zero (tare) Display is performed, the display will again change to zero and the Display offset value will shift accordingly.
Display Absolute	This function will switch the Input Display between Relative and Absolute. The Relative is a net value that includes the Display Offset Value. The Input Display will normally show the Relative unless switched by this function. Regardless of the display selected, all unit functions continue to operate based on the selection made for that output. The Absolute is a gross value without the Display Offset Value. The Absolute display is selected as long as the user input is activated (maintained action). When the user input is released, or the function key is pressed again, the input display switches back to Relative display. Absolute or Relative is momentarily displayed at transition to indicate which display is active.

Hold Display	The active display is held but all other unit functions continue as long as activated (maintained action).
Hold All	The unit disables processing the input, holds all display contents, and locks the state of all outputs as long as activated (maintained action). The serial port continues data transfer.
Sync Reading	The unit suspends all functions as long as activated (maintained action). When the user input is released, the unit synchronizes the restart of the A/D with other processes or timing events.
Store Batch	The Input Display value is added (batched) to the Totalizer at transition to activate (momentary action). The Totalizer retains a running sum of each batch operation until the Totalizer is reset. When this function is selected, the normal operation of the Totalizer is overridden and only batched Input Display values accumulate in the Totalizer.
Reset & Enable Totalizer	When activated (momentary action), the Totalizer resets to zero. The Totalizer continues to operate while active (maintained action). When the user input is released, the Totalizer stops and holds its value. This selection functions independent of the selected display.
Enable Totalizer	The Totalizer continues to operate while active (maintained action). When the user input is released, the Totalizer stops and holds its value. This selection functions independent of the selected display.
Adjust Brightness	When activated (momentary action), the display brightness changes to the next level.
Select Parameter List	Two lists of input scaling points and setpoint values (including band and deviation) are available. The display will momentarily indicate which list is active when the List B scaling is changed. Scaling List B must be enabled for this function to be performed. Scaling points can be disabled from changing to List B. However, this will always enable all configured setpoints to their List B values. If you do not want a value to change then you must make that setpoint List A and List B value the same.
Print Request	The unit issues a block print through the serial port when activated, and the serial type is set to RLC Protocol. The data transmitted during a print request and the serial type is programmed in Modbus Configuration → RS485 Configuration → Communication Type → RLC Protocol . If the user input is still active after the transmission is complete (about 100 msec), an additional transmission occurs.

If the User Input is set to Reset, you then choose the parameter to reset. More than one parameter can be chosen to be reset at the same time.

Totalizer
Max Display
Min Display
Setpoint 1 } There can be up to 6 setpoints
Setpoint 2 }

Apply settings

Save or cancel changes

Apply

Cancel

Repeat the above section for each user input to be configured.

Totalizer Configuration

Device / Totalizer

The Totalizer only calculates using the Relative Value.

Totalizer Decimal Point	
0	<input checked="" type="radio"/>
0.0	<input checked="" type="radio"/>
0.00	<input checked="" type="radio"/>
0.000	<input checked="" type="radio"/>
0.0000	<input checked="" type="radio"/>

For most applications, this matches the Input Display Decimal Point. If a different location is desired, refer to Totalizer Scale Factor.

Totalizer Time Base	
Seconds (/1)	<input checked="" type="radio"/>
Minutes (/60)	<input checked="" type="radio"/>
Hours (/3600)	<input checked="" type="radio"/>
Days (/86400)	<input checked="" type="radio"/>

This is the time base used in Totalizer accumulations. If the Totalizer is being accumulated through a user input or function key programmed for Batch, then this parameter does not apply.

Scale Factor

Enter Value (0.001 to 65.000)

1.000

For most applications, the Totalizer reflects the same decimal point location and engineering units as the Input Display. In this case, the Totalizer Scale Factor is 1.000. The Totalizer Scale Factor can be used to scale the Totalizer to a value that is different than the Input Display. Common possibilities are:

1. Changing decimal point location (example tenths to whole)
2. Average over a controlled time frame.
3. Change engineering units.

Details on calculating the scale factor are shown later.

If the Totalizer is being accumulated through a user input or function key programmed for Batch, then this parameter does not apply.

Totalizer Low Cut

Range: -1999.99 to 9999.99

-1999.99

A low cut value disables Totalizer when the Input Display value falls below the value programmed.

Enable Power Up Reset

ON

The Totalizer can be reset to zero on each unit power-up by setting this parameter to ON. Default setting is OFF.

Apply settings

Save or cancel changes

Apply

Cancel

TOTALIZER BATCHING

The Totalizer Time Base and scale factor are overridden when a user input or function key is programmed for store batch. In this mode, when the user input or function key is activated, the Input Display reading is one time added to the Totalizer (batch). The Totalizer retains a running sum of each batch operation until the Totalizer is reset. This is useful in weighing operations, when the value to be added is not based on time but after a filling event.

TOTALIZER USING TIME BASE

Totalizer accumulates as defined by:

$$\frac{\text{Input Display Value} \times \text{Totalizer Scale Factor}}{\text{Totalizer Time Base}}$$

Where:

Input Display Value - the present input reading

Totalizer Scale Factor - 0.001 to 65.000

Totalizer Time Base - (the division factor of time base)

Example: The input reading is at a constant rate of 10.0 gallons per minute. The Totalizer is used to determine how many gallons in tenths has flowed. Because the Input Display and Totalizer are both in tenths of gallons, the Totalizer Scale Factor is 1. With gallons per minute, the Totalizer Time Base is minutes (60). By placing these values in the equation, the Totalizer will accumulate every second as follows:

$$\frac{10.0 \times 1.000}{60} = 0.1667 \text{ gallon accumulates each second}$$

This results in:

10.0 gallons accumulates each minute

600.0 gallons accumulates each hour

TOTALIZER SCALE FACTOR CALCULATION EXAMPLES

1. When changing the Totalizer Decimal Point location from the Input Display Decimal Point, the required Totalizer Scale Factor is multiplied by a power of ten.

Example:

Input Decimal Point = 0	
Totalizer Decimal Point	Scale Factor
0.0	10
0	1
x10	0.1
x100	0.01
x1000	0.001

Input Decimal Point = 0.0	
Totalizer Decimal Point	Scale Factor
0.00	10
0.0	1
0	0.1
x10	0.01
x100	0.001

Input Decimal Point = 0.00	
Totalizer Decimal Point	Scale Factor
0.000	10
0.00	1
0.0	0.1
0	0.01
x10	0.001

2. To obtain an average reading within a controlled time frame, the selected Totalizer Time Base is divided by the given time period expressed in the same timing units.

Example: Average temperature per hour in a 4 hour period, the scale factor would be 0.250. To achieve a controlled time frame, connect an external timer that has a digital output wired to a PM-50 to a user input programmed for Reset Totalizer. The timer will control the start (reset) and the stopping (hold) of the totalizer.

3. To change engineering units.

Example: Change flow from liters to totalize gallons, scale factor would be 0.264.

Modbus Configuration

Device / Communication

RS485 Configuration

RS232 Configuration (With Module installed)

Ethernet Configuration (With Module installed)

RS485 or RS232 Configuration

The menus for RS485 and RS232 Configuration are the same.

Communication Type

- Modbus ASCII
- Modbus RTU
- RLC Protocol (ASCII)
- None

Baud Rate

- 1200
- 2400
- 4800
- 9600
- 19200
- 38400
- 57600
- 115200

Data Bit

7



8



Parity Bit

None



Even



Odd



Stop Bits

1



2



Modbus Station Number

Range: 1 to 247

247

If RLC Protocol is selected, the following menus appear instead of Modbus Station:

RLC Station Number

Range: 0 to 99

0

If the station number is 00, it will not be sent during a full transmission.

Enable Abbreviated Transmission



Select OFF for full print or Command T transmissions (station number, mnemonics and parameter data) or ON for abbreviated print transmissions (parameter data only). This will affect all the parameters selected in the print options.

Transmit Delay

Range: 0 to 250 ms

10

Following a transmit value (“*” or (\$) terminator) or Modbus command, the PM-50 will wait this minimum amount of time in seconds before issuing a serial response.

Print Options

Prints the relative values of the items chosen below.

Input

Totalizer

Maximum

Minimum

Setpoint Values

Apply settings

Save or cancel changes

Apply

Cancel

For more information on serial protocols see “Serial RLC Protocol Communications”.

Ethernet Configuration

Enable DHCP Client



IP Address

The IP Address for Ethernet and Wi-Fi should be different addresses. To view Ethernet IP address with Enable DHCP Client ON, you must go to About this Device and advance to the Ethernet module.

Subnet Mask

Apply settings

Save or cancel changes

Apply

Cancel

Misc. Configuration

Device / Misc.

Import / Export Configuration

Factory Configuration

Firmware Upload

Device & Module Calibration

About this Device

Reboot the Device

Misc. / Import/Export

Import Config from SD

Export Config to SD

Import ScalePoint from SD

Export ScalePoint to SD

Selecting either import option will bring up the following warning:

This will Reboot the device

Continue

Exit

Pressing continue brings up the Import screen, while Exit will return you to the main Misc. Configuration menu.

Import Config from SD Card

Filename

Import

Status:

The file name must be config.txt for a successful import. You can change the file name after exporting, however, before you import the file into a PM-50 you must change the name back to config.txt.

When using the microSD Card and you click the import button, one of the following status messages will appear based on the microSD card:

No microSD Card detected - when the microSD card is not available in the slot, or the microSD card is an incompatible size or format

File not found - If the microSD card is present, but the config.txt file does not exist

Import successful, Rebooting - When the config.txt file is imported successfully, the device reboots to activate the configuration

Export Config to SD Card

Filename

Export

Status:

Exporting a new file to the microSD Card will overwrite the existing config.txt file on the card. You can change the file name after exporting to store more than one configuration program on a separate electronic device. The config.txt file can be viewed and edited using a text editor. However, caution must be taken because one wrong space, entry, or deletion can cause the file to be not readable by the PM-50.

Use this with caution.

Import ScalePoint from SD Card

Filename

Import

Status:

Export ScalePoint to SD Card

Filename

Export

Status:

After completing the import / export operation, press the left arrow twice to return to the main Misc Configuration Menu.

Factory Configuration

Misc. / Factory

Enable Screen Calibration



This is the Factory Default setting.

Enable Screen Calibration



Device Requires Reboot

This setting will allow calibration of the Touch screen upon reboot of the device. If calibration of the screen is done incorrectly, a reboot will allow the calibration to be done again. Remember to turn off after successful calibration.

Perform Factory Default



This is the Factory Default setting.

Perform Factory Default



Setting this switch to ON brings up the following warning screen. Pressing the **Proceed** button immediately resets and restarts the device. All user settings are returned to Factory Default, including the Admin password. This will also restart the Programming Wizard.



Warning

This will reset all device configuration to Factory Default values.

DEVICE WOULD RESTART AFTER RESET

Cancel

Proceed

Enable Programming Wizard



This will automatically go back to off after reboot. The Wizard will have the previous programmed configurations.

Enable Programming Wizard



Device Requires Reboot

This will automatically go back to off after reboot. The Wizard will have the previous programmed configurations.

Apply settings

Save or cancel changes

Apply

Cancel

Firmware Upload

Misc. / Firmware Upload

Firmware details

SD Card Firmware
Firmware Name
Firmware Version

Active Firmware
Firmware Name
Firmware Version

Firmware details are displayed with an Upload button. It will show the SD card firmware version and the firmware version presently in the PM50. The gpmcore.fwb file will auto detect the PM50 model. It is strongly suggested that the configuration in the PM50 (config.txt file) be saved to a separate SD card before updating to a new firmware version.

SD Card Firmware Upload
(Device will be rebooted)
Firmware Name
Firmware Version

Press the Upload button at the bottom of the screen to perform the upload of firmware from the SD card.

Firmware Upload Status

Firmware Name
Firmware Version
Verifying Package Complete
Fetching Binary
Please wait ...

During the upload of the firmware, a screen appears showing the status of the upload. Once the upload is complete the unit resets to the main menu. User settings from the previous firmware are retained.

Note: Do not disconnect power during the upload process. Loss of power could result in unit failure.

Device & Module Calibration

Device / Calibration
Device Calibration
AO Module Calibration

Device Calibration

Misc. / Calibration

The unit has been fully calibrated at the factory. Scaling to convert the input signal to a desired display value is performed in Signal Input Configuration. If the unit appears to be indicating incorrectly or inaccurately, refer to Troubleshooting before attempting to calibrate the unit. When recalibration is required (generally every 2 years), it should only be performed by qualified technicians using appropriate equipment. Calibration does not change any user programmed parameters. However, it will affect the accuracy of the input signal and the values previously stored using the Apply Scaling Style.

Enter Access Code

0

Access Code for calibration is 48.

Starting Calibration Procedure

will require Reboot to Exit.

START

CANCEL

After pressing the START button, the device displays the Input Type screen allowing you to select the input type you want to calibrate. After making that selection, it will display the Range associated with that

input. Once calibration has been started, you **MUST** go through each of the steps. The unit will not allow you to exit without completing calibration. It is possible to abort calibration by removing power, however this is not recommended.

After selecting the range, the following screen is shown.

Mode of Calibration ‡	
Auto	<input checked="" type="radio"/>
Manual	<input type="radio"/>

It is recommended that you use the “auto” mode to perform calibration. The manual mode is mainly a diagnostic tool to mke small adjustments to a previously auto calibrated device.

‡ The Range being calibrated will be shown here.

Auto Offset Calibration ‡	
Apply Short to Input, Press Start	
<input type="text" value="2-0.000677"/>	
<input type="button" value="START"/>	

‡ The Range being calibrated will be shown here.

Auto Offset
Wait a minimum of 8 seconds
CALIBRATING...

Auto Gain Calibration ‡

Apply Signal to Input, Press Start

0.0000

START

For Auto Gain Calibration, apply the exact signal value shown on the display that corresponds to the Input Range you are calibrating to the Input.

‡ The Range being calibrated will be shown here.

Auto Gain

Wait a minimum of 8 seconds
CALIBRATING...

Calibration Value‡

For more Calibration click button(s)

00000

OFFSET: ####

GAIN: ####

‡ The Range being calibrated will be shown here.

Save Calibration Values

SAVE

CANCEL

If you choose to CANCEL Calibration, the following menu appears.

Continue Calibration ?

CONTINUE

EXIT

AO Module Calibration

Enter Access Code

Access Code for calibration is 48.

Input Range

4 to 20 mA

0 to 20 mA

0 to 10 VDC

-10 to +10 VDC

Select the Input Range for the Analog Output that you want to calibrate.

Zero-offset ‡

Enter Value shown on Meter

‡ The Range being calibrated will be shown here.

Gain ‡

Enter Value shown on Meter

‡ The Range being calibrated will be shown here.

Save Calibration Values

SAVE

CANCEL

If you choose to CANCEL Calibration, the following menu appears.

Continue Calibration ?

CONTINUE

EXIT

About this Device

Misc. / **About**

About this Device

General Information
Size:
Type:
Firmware Version:
Secure Boot:
Serial Number:
Part Number:

All of the General Information about this device will be displayed on this screen. Pressing the next arrow will advance through the screens showing the information about Network and module information (MAC ID, IP address etc). This is followed by a screen listing the Part Numbers of all installed modules. To exit this menu, press Misc. / **About** menu header or one of the Configuration icons.

The following screen is an example of the Network information that will be displayed.

About this Device

Network Information
Wi-Fi MAC:
IP Info:
Wi-Fi Status:

The following screen is an example of the Ethernet module information that will be displayed. The information displayed will be module dependent.

About this Device

Ethernet Module Information
Part Number:
IP Info (Static):
Subnet Mask:
Ethernet Module MAC::
Ethernet Status:

The following is an example of what will be displayed depending on the modules you have installed.

About this Device

Modules Part Number:
Analog Out: PMM000IOAN000000
RS232: PMM000CM23200000
Ethernet: PMM000CMEN000000
Quad Relay: PMM000IORL400000:

Reboot the Device

Misc. / Reboot

This will Reboot the device

Continue

Exit

Pressing continue immediately reboots (power cycles) the unit and returns you to the main display, while Exit will return you to the main Misc. Configuration menu.



Home Screen

Screen Configuration

Screen Set-up

Update screen



Home Screen

This section allows the user to configure the 4 screens to display the device status and statistics based on the display size. These additional page views can be accessed from the Main Display by swiping either left or right.

1. For 3.5" display size, one screen/widget per page view.
2. For 4.3" display size, two screens/widgets per page view. The 4.3 will also support combining two screens to create a large numeric widget for displaying status and statistics.

System / Home Screen

Large Numeric Widget

Widget Selection

Display Limit

Screen / Large Numeric

Enable Large Numeric Mode (Only for 4.3" models)

Merge Home screen 3 & 4 together as Numeric Widget



Your choices are either ON to merge screens 3 & 4, or OFF which disables the large numeric.

Apply settings

Save or cancel changes

Apply

Cancel

Widget Selection

Screen

Screen Number

1



2



3



4



If Large Numeric Mode was enabled, 3 and 4 are replaced with Large Numeric selection.

Screen (1)

Display Style

- None
- Gauge
- Temperature
- Setpoint Status
- Numeric
- Max Min Total Monitor

For Gauge, Temperature and Numeric selections, the following menus appear.

Signal Type

- Analog Input
- Totalizer

The Analog Input value shown will be based on the active scaling List A or B and the active Absolute or Relative selection.

Display Units

units

Display Units is a 10 digit title that can be used to describe the numbers being shown. This title will remain the same when switching between lists and Absolute and Relative. This selection does not appear if the Display Style is set for Temperature.

The Maximum and Minimum Display Values are only applicable for Gauge and Temperature. The valid range for Gauge widget inputs is -999999999 to 999999999 and for the Gauge Totalizer -999999999 to

999999999. The range for Temperature widget is -99999 to 99999. The min values must be lower than the max values.

Minimum Display Value

0

Maximum Display Value

200

Color Band 1

Red



Blue



Green



Yellow



Percentage Band 1

20

Color Band 2

Red



Blue



Green



Yellow



Percentage Band 2

60

Color Band 3

Red



Blue



Green



Yellow



Percentage Band 3

100

Setpoint Status

Setpoint Status will display the independent status of the setpoint using a colored circle. It will not show the value for the setpoint. Setpoint 1 and 2 are always shown as part of the main icons.

Max Min Total Monitor

All three displays will always show with this selection even though they may not be activated. To keep one or more of the displays from showing a value, you must activate a User Input or Function Key for maintain reset of that display.

Apply settings

Save or cancel changes

Apply

Cancel

Display Limit

Max Display Limit

Maximum digit to be displayed

7 digit display



9 digit display



Apply settings

Save or cancel changes

Apply

Cancel

Note: 7 Digit Display appears bigger than 9 Digit Display

Supervisor/Quick Access Mode

In Supervisor/Quick Access Mode, function keys have different characteristics. The function keys are shown at the bottom of the home screen. If the Supervisor mode is disabled key programmed for All Users), the function key is red. When a function key is configured as a Supervisor key, the function key is green. The function key is yellow to indicate that the assigned function is maintained active.

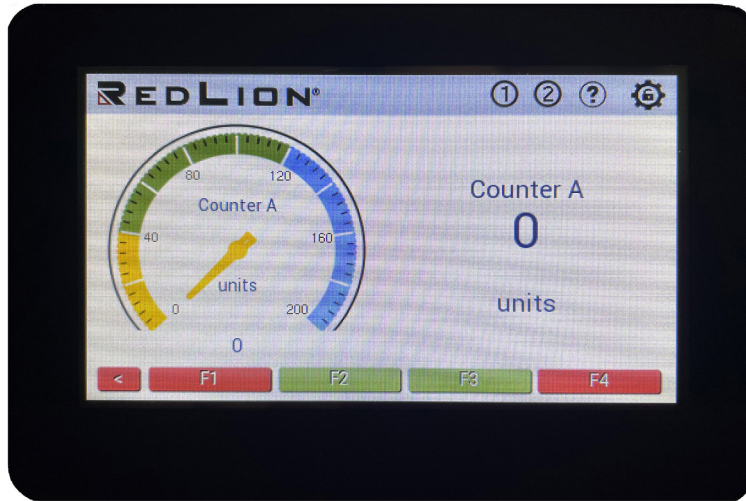

Admin Mode

When logged in as admin and a function key is pressed, it directly triggers the event it is assigned to, or it redirects to the configuration page to adjust the value it is assigned to. When the configuration is saved, the PM50 automatically redirects to the home page. If the user stays idle on the configuration page for 10 minutes, the user gets logged out and automatically redirected to the home page.

Supervisor Mode

Supervisor mode should be enabled from the PM50 device only and by default, it is off. To enable Supervisor mode follow the steps listed below:

Login as Admin on the PM50 device

Login

User Type

Admin

Password

LOG IN **Cancel**

Tap on the System tab and navigate to Account Configurations

User Access

User Account

Enable the Supervisor Mode toggle, then click on the right arrow.

System / Account

Enable Supervisor Password

OFF

Password Recommended to make the configuration secure.

Enter the Supervisor password, then click on the right arrow.

System / Account

Set Supervisor Password

Enter New Password for Supervisor

Click to Re-enter and Confirm Password

Re-enter the previously entered password. If the password matches, click on the confirm button.

System / Account

Set Supervisor Password

Re-Enter New Password for Supervisor

Password Match. Confirm to proceed

Ignore Confirm

Apply settings

Save or cancel changes

Apply Cancel

Note: Only the Admin can set up Supervisor mode on the PM50 device. If the password is not set by the Admin for Supervisor, then Supervisor mode is not enabled.

Function Key Configurations

The Function Key configuration is used for assigning function keys to the Supervisor mode. When the user enables Supervisor mode an added Access option is seen on the function key configuration page. It has two options: Supervisor and All Users. Here one can enable the Supervisor mode for that specific function key. When the user selects the Supervisor in the access option, the available functions are changed. The following options are available on the PM50 Digital: None, Setpoint Value, Momentary Reset, Display Brightness, Count Load

Device / Function

Function Key Configuration

User Input Configuration

Function / Key

Enable Function Key



Function / Key

Function Key

F1



F2



F3



F4



Functions / Key (1)

Function Key

Supervisor



All User



Functions / Key (1)

Rename Key

Functions / Key (1)

Select Function

None

Setpoint Value

Momentary Reset

Display Brightness

Count Load

Apply settings

Save or cancel changes

Apply

Cancel

Home Screen

The home screen has function keys shown at the bottom of the screen. If the Supervisor mode is disabled, the function key takes red color. When a function key is configured as a Supervisor key, the function key takes green color.

Admin Mode

When tapped on the function key, it directly triggers the event it is assigned or redirects to the configuration page i.e., in case it is assigned a setpoint value, count load, display, or adjust brightness. When the configuration is saved, it automatically redirects to the home page. If the user stays idle on this page for 10 minutes the user gets logged out and automatically redirected to the home page.

Logged Out Mode (Supervisor)

When tapped on the function key it redirects to the login page. There it shows two options for login as Admin or Supervisor. The Supervisor is the default option. When the user logs in the event get triggered, and the user is logged out and redirected to the home page, this is in the case of the reset function, else it redirects to the respective configuration page. When the configuration is saved, the device automatically logs out and redirects to the home page. If the user stays idle for 30 seconds the user gets logged out and automatically redirected to the home page.

Logged Out Mode (Admin)

When the user presses the function key it redirects to the login page. On the login page, we have two options Admin & Supervisor. The Supervisor is the default selected option user can also select Admin if the user wants to log in as Admin. After password authentication for reset functionality, the reset action gets triggered & the page returns to the home page. For configuration functionality like setpoint value then the page is directed to the setpoint selection page & after configuration when the user saves the configuration Admin is logged out & the user is directed to the home page.

Function Key Scenarios

Listed below are a few of the scenarios you may observe when a website and/or mobile device is connected to your PM50.

Admin User Logged In On The Website

If a user is logged in on the website as admin and a function key is pressed, the PM50 display shows a popup message saying “Remote user is logged in. Please try again later.” When the Supervisor-enabled function key is pressed, the device screen navigates to the login page, and it shows the message “Remote user is logged in. Please try again later.”

Admin User Logged In On Device:

If a user is logged in on the PM50 as admin and a function key is pressed, the website shows a popup message saying “Admin/Supervisor user is logged in on the device.” When the Supervisor enabled function key is pressed, the website screen navigates to the login page, and it shows the message “Admin/Supervisor user is logged in on the device. Supervisor functions cannot be triggered. Please try again later.”

Active State On Device And Website:

On the PM50, this scenario is observed when the Supervisor function key is pressed, and the user has logged in and is on the configuration page on the website. Now, the function key on the device turns yellow to indicate that the remote user is on the configuration screen on the website. Once the remote user saves or redirects to the home page, the PM50 reverts the function key color to its previous state i.e., red, or green. This change in function key colors will be observed on the website as well.

Page Timeout for Each Login

PM50 DEVICE			
Logged In	Supervisor (Disabled)	Supervisor (Enabled)	
		Supervisor	All Users
Admin	10 mins	30 secs	10 mins
Supervisor	N/A	30 secs	N/A

WEBSITE / MOBILE APPLICATION			
Logged In	Supervisor (Disabled)	Supervisor (Enabled)	
		Supervisor	All Users
Admin	30 secs	10 mins	30 secs
Supervisor	N/A	30 secs	N/A

Serial RLC Protocol Communications

Command Chart

COMMAND	DESCRIPTION	NOTES
N	Note (unit) Address Specifier	Address a specific unit. Must be followed by a one or two digit node address. Not required when address = 0.
T	Transmit Value (read)	Read a register from the unit. Must be followed by register ID character.
V	Value Change (write)	Write to register or output. Must be followed by register ID character and numeric data.
R	Reset	Reset a register or output. Must be followed by register ID character.
P	Block Print Request	Initiates a block print output. Registers are defined in programming.

Command String Construction

The command string must be constructed in a specific sequence. The unit does not respond with an error message to invalid commands. The following procedure details construction of a command string:

1. The first characters consist of the Node Address Specifier (N) followed by a 1 or 2 character address number. The address number of the unit is programmable. If the node address is 0, this command and the node address itself may be omitted. For node address 1 through 9, a leading zero character is not required. (The only exception is a numeric transmission when Counter C is set for slave mode.) This is the only command that may be used in conjunction with other commands.
2. After the optional address specifier, the next character is the command character.
3. The next character is the Register ID. This identifies the register that the command affects. The P command does not require a Register ID character. It prints according to the selections made in print options.
4. If constructing a value change command (writing data), the numeric data is sent next.
5. All command strings must be terminated with the string termination characters *, \$ or when Counter C is set for slave mode <CR>. The unit does not begin processing the command string until this character is received. See Timing Diagram figure for differences between terminating characters.

Sending Numeric Data

Numeric data sent to the unit must be limited to the digit range shown under transmit details in the Register Identification Chart. Leading zeros are ignored. Negative numbers must have a minus sign. The unit ignores any decimal point and conforms the number to the scaled resolution. (For example: the unit's scaled decimal point position = 0.0 and 25 is written to a register. The value of the register is now 2.5. Note: Since the unit does not issue a reply to value change commands, follow with a transmit value command for readback verification.

Register Identification Chart

ANALOG MODEL				
ID	VALUE DESCRIPTION	MNEMONIC APPLICABLE	COMMANDS	TRANSMIT DETAILS
A	Input (relative value)	INP	T, P, R (Reset command resets input to zero; tares)	9 digit, 8 ½ negative
B	Total	TOT	T, P, R (Reset command resets total to zero)	9 digit, 8 ½ negative
C	Max Input	MAX	T, P, R (Reset command resets Max to current reading)	9 digit, 8 ½ negative
D	Min Input	MIN	T, P, R (Reset command resets Min to current reading)	6 positive, positive only
E	Setpoint 1	SP1	T, P, V, R (Reset command resets the setpoint output)	6 positive, positive only
F	Setpoint 2	SP2		6 positive, positive only
G	Setpoint 3	SP3		6 positive, 5 ½ negative
H	Setpoint 4	SP4		6 positive, 5 ½ negative
I	Band/Deviation 1	BD1	T, V	6 positive, positive only
J	Band/Deviation 2	BD2	T, V	6 positive, positive only
K	Band/Deviation 3	BD3	T, V	6 positive, 5 ½ negative
L	Band/Deviation 4	BD4	T, V	6 positive, 5 ½ negative
M	Absolute Input Value	ABS	T	6 positive, 5 ½ negative
O	Offset	OFS	T, V	6 positive, 5 ½ negative
P	Band/Deviation 5	BD5	T, V	
Q	Band/Deviation 6	BD6	T, V	6 positive, 5 ½ negative
S				
U	Auto/Manual Register	MMR	T, V	0 - auto; 1 - manual
W	Analog Output Register	AOR	T, V	0 - 65536 normalized
X	Setpoint Register	SOR	T, V	0 - not active; 1 - active
Y	Setpoint 5	SP5	T, P, V, R (Reset command resets the setpoint output)	6 positive, 5 ½ negative
Z	Setpoint 6	SP6		6 positive, 5 ½ negative

Command String Examples

1. Node address = 17, Write 350 to Setpoint 1.
String: N17VM350\$
2. Node address = 5, Read Count A value.
String: N5TA*
3. Node address = 0, Reset Setpoint 4 output.
String: RS*

Receiving Data From the Unit

Data is transmitted by the unit in response to either a transmit command (T), a print block command (P) or User Function print request. The response from the unit is either a full field transmission or an abbreviated transmission. The unit response mode is selected in Serial Port Parameters (Abrv).

Full Field Transmission (Address, Mnemonic, Numeric data)

Byte	Description
1, 2	2 byte Node Address field [00-99]
3	<SP> (Space)
4-6	3 byte Register Mnemonic field
7-18	12 byte data field, 10 bytes for number, one byte for sign, one byte for decimal point
19	<CR> carriage return
20	<LF> line feed
21	<SP>* (Space)
22	<CR>* carriage return
23	<LF>* line feed

* These characters only appear in the last line of a block print.

The first two characters transmitted are the node address, unless the node address assigned = 0, in which case spaces are substituted. A space follows the node address field. The next three characters are the register mnemonic.

The numeric data is transmitted next. The numeric field is 12 characters long (to accommodate the 10 digit totalizer), with the decimal point position floating within the data field. Negative values have a leading minus sign. The data field is right justified with leading spaces.

The end of the response string is terminated with a carriage return <CR> and <LF>. When block print is finished, an extra <SP><CR> <LF> is used to provide separation between the blocks.

Abbreviated Transmission (Numeric data only)

Byte	Description
1-12	12 byte data field, 10 bytes for number, one byte for sign, one byte for decimal point
13	<CR> carriage return
14	<LF> line feed
15	<SP>* (Space)
16	<CR>* carriage return
17	<LF>* line feed

* These characters only appear in the last line of a block print.

Unit Response Examples:

1. Node address = 17, full field response, Count A = 875
17 CTA 875 <CR><LF>
2. Node address = 0, full field response, Setpoint 2 = -250.5
SP2 -250.5<CR><LF>
3. Node address = 0, abbreviated response, Setpoint 2 = 250, last line of block print
250<CR><LF><SP><CR><LF>

Auto/Manual Mode Register (MMR) ID: U

This register sets the controlling mode for the outputs. In Auto Mode (0) the unit controls the setpoint and analog output. In Manual Mode (1) the outputs are defined by the registers SOR and AOR. When transferring from auto mode to manual mode, the unit holds the last output value (until the register is changed by a write). Each output may be independently changed to auto or manual. In a write command string (VU), any character besides 0 or 1 in a field will not change the corresponding output mode.

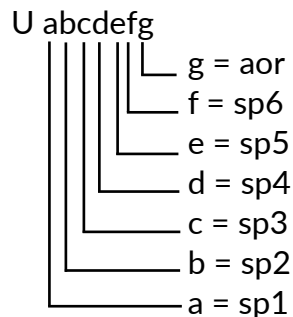

Analog Output Register (AOR) ID: W

This register stores the present signal value of the analog output. The range of values of this register is 0 to 32767, which corresponds to the analog output range per the following chart:

REGISTER VALUE	OUTPUT SIGNAL*		
	0-20 mA	4-20 mA	0-10 V
0	0.000	4.000	0.000
8192	5.000	8.000	2.500
16384	10.000	12.000	5.000
32767	20.000	20.000	10.000

* Due to the absolute accuracy rating and resolution of the output card, the actual output signal may differ 0.15% FS from the table values. The output signal corresponds to the range selected (0-20 mA, 4-20 mA or 0-10 V).

Writing to this register (VW) while the analog output is in the Manual Mode causes the output signal level to update immediately to the value sent. While in the Automatic Mode, this register may be written to, but it has no effect until the analog output is placed in the manual mode. When in the Automatic Mode, the unit controls the analog output signal level. Reading from this register (TW) will show the present value of the analog output signal.

Example: VW16384* will result in an output of 10.000 mA, 12.000 mA or 5.000V depending on the range selected.

Setpoint Output Register (SOR) ID: X

This register stores the states of the setpoint outputs. Reading from this register (TX) will show the present state of all the setpoint outputs. A "0" in the setpoint location means the output is off and a "1" means the output is on.

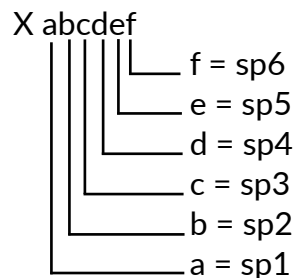

In Automatic Mode, the unit controls the setpoint output state. In Manual Mode, writing to this register (VX)

will change the output state. Sending any character besides 0 or 1 in a field or if the corresponding output was not first in manual mode, the corresponding output value will not change. (It is not necessary to send least significant 0s.)

Example: VX10* will result in output 1 on and output 2 off.

Hardware Setup

For the most up to date specifications refer to the Installation Guide for your specific model. Found [here](#). Specification information for specific modules can be found at the same location.

Specifications

Note: The PM-50 4.3 inch host accepts a maximum of 5 modules while the 3.5 inch host accepts a maximum of 3 modules. Only one module from each function type (i.e. communication, relay, analog output) can be installed.

POWER: The meter is intended to be powered by NEC/CEC class 2, IEC/EN/UL 60950-1 LPS or UL/CSA 601010-1 Limited Energy power source.

MODEL	4.3-INCH	3.5-INCH
Input Voltage (Volts)	10-30 VDC	10-30 VDC
Max Power PM-50 only	4.6 W	4.6 W
Max Power PM-50, with modules	12 W	12 W

Host Isolation: 500 Vrms for 1 min. to all inputs and outputs.

DISPLAY: 4.3" or 3.5" Color TFT display with resistive analog touch screen

SIZE	4.3-INCH	3.5-INCH
TYPE	TFT	TFT
COLORS	262,144 K	262,144 K
PIXELS	480 X 272	320 X 240
BRIGHTNESS	420 cd/m ²	540 cd/m ²
LED BACKLIGHT LIFE*	30,000 HR TYP.	30,000 HR TYP.

A/D CONVERTER: 24 bit resolution

UPDATE RATES:

A/D Conversion Rate: Programmable 5 to 200 readings/sec.

Step Response:

Input Type (Readings/Sec)	INPUT UPDATE RATE (msec RESPONSE TIME *)				
	10	20	50	100	200
V/I/Resistance	200	100	40	20	10
Thermocouple	250	100	-	-	-

INPUT UPDATE RATE (msec RESPONSE TIME *)					
RTD	500	250	-	-	-

* - max. to within 99% of final readout value (digital filter disabled)

Display Update Rate: 1 to 20 updates/sec.

Setpoint Output ON/OFF Delay Time: 0 to 3275 sec.

Max./Min. Capture Delay Time: 0 to 3275 sec.

INPUT CAPABILITIES:

Current Input:

MAX INPUT RANGE	ACCURACY* (18 to 28 °C)	ACCURACY* (-10 to 55 °C)	IMPEDANCE	± RESOLUTION
± 200 µA DC	0.03% of rdg + 0.03 µA	0.12% of rdg + 0.04 µA	100 Ω	10 nA
± 2 mA DC	0.03% of rdg + 0.3 µA	0.12% of rdg + 0.4 µA	100 Ω	0.1 µA
± 20 mA DC	0.03% of rdg + 3 µA	0.12% of rdg + 4 µA	100 Ω	1 µA
± 200 mA DC	0.05% of rdg + 30 µA	0.12% of rdg + 40 µA	0.06 Ω	10 µA
± 2 A DC	0.5% of rdg + 0.3 mA	0.7% of rdg + 0.4 mA	0.06 Ω	0.1 mA

Voltage Input:

Impedance: 625 KΩ

MAX INPUT RANGE	ACCURACY* (18 to 28 °C)	ACCURACY* (-10 to 55 °C)	± RESOLUTION
± 200 mV DC	0.03% of rdg + 30 µV	0.12% of rdg + 40 µV	10 µV
± 2.0 V DC	0.03% of rdg + 0.3 mV	0.12% of rdg + 0.4 mV	0.1 mV
± 20 V DC	0.03% of rdg + 3 mV	0.12% of rdg + 4 mV	1 mV
± 60 V DC	0.3% of rdg + 30 mV	0.12% of rdg + 40 mV	10 mV

Thermocouple Inputs:

Readout Scale: °F or °C

Input Impedance: 20 MΩ

Lead Resistance Effect: 0.09 μV/Ω

Max Continuous Overvoltage: 30 V

INPUT TYPE	RANGE	ACCURACY* (18 to 28 °C)	ACCURACY* (-10 to 55 °C)	STANDARD	WIRE COLOR	
					ANSI	BS 1843
T	-200 to 400 °C	1.2 °C	2.1 °C	ITS-90	(+) blue (-) red	(+) white (-) blue
E	-200 to 750°C	1.0 °C	2.4 °C	ITS-90	(+) purple (-) red	(+) brown (-) blue
J	-200 to 760 °C	1.1 °C	2.3 °C	ITS-90	(+) white (-) red	(+) yellow (-) blue
K	-200 to 1250 °C	1.3 °C	3.4 °C	ITS-90	(+) yellow (-) red	(+) brown (-) blue
R	0 to 1768 °C	1.9 °C	4.0 °C	ITS-90	no standard	(+) white (-) blue
S	0 to 1768 °C	1.9 °C	4.0 °C	ITS-90	no standard	(+) white (-) blue
B	150 to 300 °C 300 to 1820 °C	3.9 °C 2.8 °C	5.7 °C 4.4 °C	ITS-90	no standard	no standard
N	-200 to 1300 °C	1.3 °C	3.1 °C	ITS-90	(+) orange (-) red	(+) orange (-) blue
C (W5/W26)	0 to 2315 °C	1.9 °C	6.1 °C	ASTM E988-90**	no standard	no standard

RTD Inputs:

Readout Scale: °F or °C

Type: 3 or 4 wire, 2 wire can be compensated for lead wire resistance

Excitation Current: 100 Ω range: 136.5 μA ±10%

10 Ω range: 2.05 mA ±10%

Lead Resistance: 100 Ω range: 10 Ω /lead max.

10 Ω range: 3 Ω/lead max.

Max. Continuous Overload: 20 VDC

INPUT TYPE	RANGE	ACCURACY* (18 to 28 °C)	ACCURACY* (-10 to 55 °C)	STANDARD **
100 Ω Pt alpha = .00385	-200 to 850°C	0.4 °C	1.6 °C	IEC 751

INPUT TYPE	RANGE	ACCURACY* (18 to 28 °C)	ACCURACY* (-10 to 55 °C)	STANDARD **
100 Ω Pt alpha = .00392	-200 to 850°C	0.4 °C	1.6 °C	no official standard
120 Ω Nickel alpha = .00672	-80 to 259°C	0.2 °C	0.5 °C	no official standard
10 Ω Copper alpha = .00427	-110 to 260°C	0.4 °C	0.9 °C	no official standard

Resistance Inputs:

Max. Continuous Overload: 20 VDC

MAX INPUT RANGE	ACCURACY* (18 to 28 °C)	ACCURACY* (-10 to 55 °C)	COMPLIANCE	‡ RESOLUTION
100 Ω	0.05% of rdg +0.3 Ω	0.2% of rdg +0.4 Ω	0.175 V	0.1 Ω
1000 Ω	0.05% of rdg+0.3 Ω	0.2% of rdg +0.4 Ω	1.75 V	1 Ω
10 KΩ	0.05% of rdg +1 Ω	0.2% of rdg +1.5 Ω	17.5 V	1 Ω

‡ Higher resolution can be achieved via input scaling.

* After 20 min. warm-up, @ 10 sample per second input rate. Accuracy is specified in two ways: Accuracy over an 18 to 28 °C and 15 to 75% RH environment; and Accuracy over a -10 to 55 °C and 0 to 85% RH (non condensing) environment. The specification includes the A/D conversion errors, linearization conformity, and thermocouple ice point compensation. Total system accuracy is the sum of unit and probe errors. Accuracy may be improved by field calibrating the unit readout at the temperature of interest.

** These curves have been corrected to ITS-90.

EXCITATION POWER:

Transmitter Power: +24 VDC, ± 5% @ 50 mA max.

Reference Voltage: + 2 VDC, ± 2%

Compliance: 1 KΩ load min (2 mA max)

Temperature Coefficient: 40 ppm/°C max.

Reference Current: 1.05 mADC, ± 2%

Compliance: 10 KΩ load max (2 mA max)

Temperature Coefficient: 40 ppm/°C max.

USER INPUTS: Two programmable user inputs

Max. Continuous Input: 30 VDC

Isolation to Sensor Input Common: Not isolated.
 Logic State: User programmable for sink/source (Lo/Hi)

INPUT STATE	LO/SINK	HI/SOURCE
	20 K Ω pull-up to +3.3 V	20 K Ω pull-down
Active	$V_{IN} < 0.9$ VDC	$V_{IN} > 2.4$ VDC
Inactive	$V_{IN} > 2.4$ VDC	$V_{IN} < 0.9$ VDC

TOTALIZER:

Time Base: second, minute, hour, or day
 Batch: Can accumulate (gate) input display from a user input
 Time Accuracy: 0.01% typical
 Decimal Point: 0 to 0.0000
 Scale Factor: 0.001 to 65.000
 Low Signal Cut-out: -199,999 to 999,999
 Total: Up to 9 digits

CUSTOM LINEARIZATION:

Data Point Pairs: Selectable from 2 to 40
 Display Range: -199,999 to 999,999
 Decimal Point: 0 to 0.0000

MEMORY: Nonvolatile memory retains all programmable parameters and display values.

Memory Card: microSD slot accepts up to 32 GB capacity cards in FAT16/FAT32 format.

RS485 SERIAL PORT: Uses Modbus protocol

Baud Rate: Up to 115,200
 Data Format: 7/8 bit; odd, even, or no parity; 1 or 2 stop bits
 Isolation: 500 Vrms to sensor, user power and digital inputs. Not isolated to solid state outputs

Wi-Fi CAPABILITIES:

Wi-Fi: Power output up to 20.5 dBm
 Frequency:

TECHNOLOGY	CHANNELS	FREQUENCIES
Wi-Fi	1-13	2412-2484 MHz

Note: Channel/frequency limitation is enforced based on configured country/region code.

Wi-Fi Compliance: TCP/IP; 802.11 b/g/n

ON-BOARD DUAL SSR OUTPUTS: Both outputs must be used either in SINKING or in SOURCING mode

together.

Sinking Mode:

Type: Switched DC, N-channel open drain MOSFET

Max Sink Current: 100 mA

V_{DS} ON: 0.3 V @ 100 mA

V_{DS} MAX: 30 VDC

Offstate Leakage Current: 0.5 mA max

Sourcing Mode:

Type: Switched DC, P-channel open source MOSFET

Max Source Current: 100 mA

V_{DS} ON: 0.3 V @ 100 mA

V_{DS} MAX: 30 VDC

Offstate Leakage Current: 0.5 mA max

ENVIRONMENTAL CONDITIONS:

Operating Temperature Range: -10 to 55 °C

Storage Temperature Range: -20 to 60 °C

Operating and Storage Humidity: 0 to 85% max. RH non-condensing

Vibration to IEC 68-2-6: Operational 5-500 Hz, 2 g

Shock to IEC 68-2-27: Operational 20 g (10 g relay)

Altitude: Up to 2000 meters

Installation Category II, Pollution Degree 2 as defined in IEC/EN 60664-1.

CERTIFICATIONS AND COMPLIANCES:

CE Approved

EN 61326-1 Immunity to Industrial Locations

Emission CISPR 11 Class A

IEC/EN 61010-1

RoHS Compliant

FCC ID #: 2AC7Z-ESP32WROOM32U

UL Hazardous: File # E317425

Type 4X Indoor/IP65 Enclosure rating (Face only) for all models

IP20 Enclosure rating (Rear of unit)

CONNECTIONS: High compression spring-clamp terminal block

Wire Strip Length: 0.32-0.35" (8-9 mm)

Wire Gauge Capacity: Four 28 AWG (0.32 mm) solid,
two 20 AWG (0.61 mm) or one 16 AWG (2.55 mm)

CONSTRUCTION: This unit is rated NEMA 4X/IP65 for indoor use only. IP20 Touch safe. One piece bezel/
case. Flame resistant. Panel gasket, module locks, and mounting panel latch included.

MOUNTING REQUIREMENTS: Maximum panel thickness is 0.25" (6.35 mm). For NEMA 4X/IP65 sealing, a
steel panel with a minimum thickness of 0.04" (1.02 mm) is recommended.

Panel Latch Screw Torque: 5.0 lbf-in (0.56 Nm) **CAUTION: DO NOT OVERTIGHTEN**

WEIGHT:

4.3: 11.3 oz (321 g)

3.5: 7.9 oz (224 g)

Ordering Information

DESCRIPTION	PART NUMBER
4.3" Analog Input Graphical Panel Meter	PM500A0400800F00
3.5" Analog Input Graphical Panel Meter	PM500A0301600F00

Accessories

TYPE	DESCRIPTION	PART NUMBER
Modules	RS232 Serial Communications Module	PMM000CM23200000
	Ethernet Communications Module	PMM000CMEN000000
	Analog Output Module	PMM000IOAN000000
	Dual Setpoint Relay Output Module	PMM000IORL200000
	Quad Setpoint Relay Output Module	PMM000IORL400000
	AC to DC Power Module	PMM000PWACP000000
Misc.	Replacement Rear Cover/Bus Board with Spacer Module (4.3" model only)	PMA000CP00800000
	Conversion Panel 92 mm x 75 mm to 1/8 DIN	PMA000MK00800000
	Conversion Panel 68 mm x 68 mm to 1/16 DIN	PMA000MK01600000
	Replacement Module Lock Pins	PMA000MKLP000000
	4.3" Protective Screen Overlay	PMA000SP00800000
	3.5" Protective Screen Overlay	PMA000SP01600000
	MicroSD Card	SD032G00

DIMENSIONS In inches [mm]

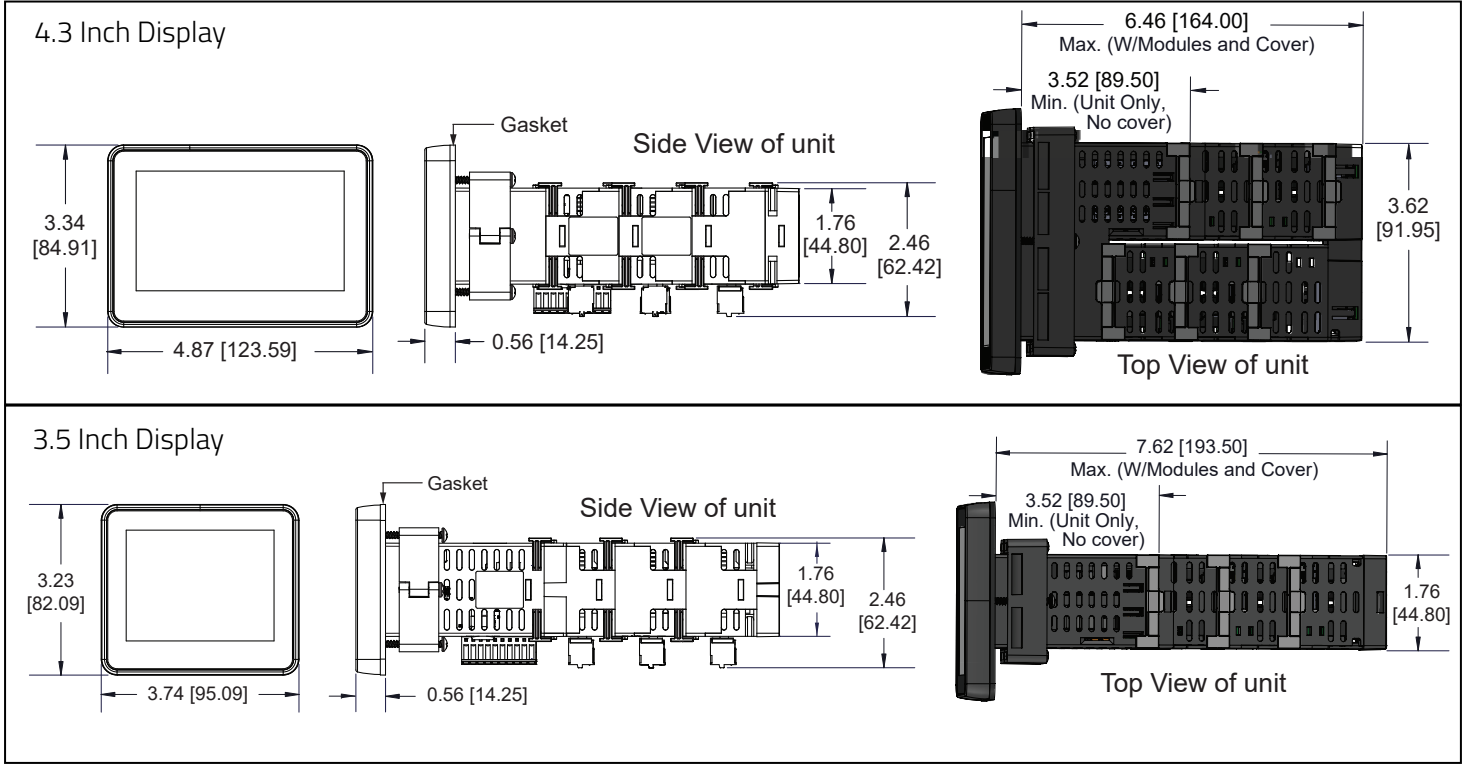

INSTALLATION ENVIRONMENT

The unit should be installed in a location that does not exceed its own operating temperature and provides good air circulation. Placing the unit near devices that generate excessive heat should be avoided.

The PM-50 4.3 and 3.5 inch models meet NEMA 4X/IP65 requirements when properly installed. This unit is designed for through-panel mounting. The mounting surface should have a minimum thickness of 0.04" (1.02 mm) and maximum thickness of 0.25" (6.35 mm). Cut the mounting hole per the dimensions shown in the diagram. Care should be taken to remove any loose material from the mounting cut-out to prevent that material from falling into the unit during installation. Prepare the panel cutout to the dimensions shown.

4.3 Inch Meter (1/8 DIN Cut Out)

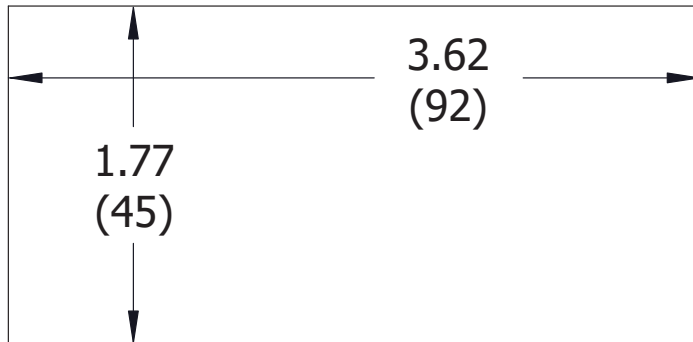

3.5 Inch Meter (1/16 DIN Cut Out)

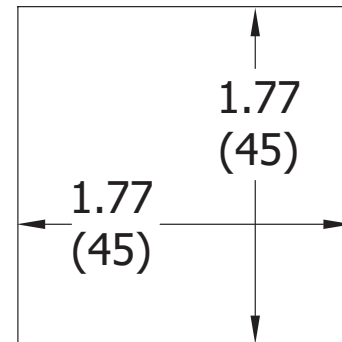

For hazardous location installation the following shall be taken into consideration:

- The device shall be panel mounted in a tool accessible enclosure with a minimum ingress protection rating of at least IP64 as defined in IEC/EN 60529.
- This device is open-type and must be mounted in a suitable dust-tight end-enclosure in accordance with articles 500 and 502 of the NEC and positioned so only the face of the display is exposed.
- Must be wired using Division 2 wiring methods as specified in article 501-4(b), 502-4(b), and 503-3(b) of the National Electric Code, NFPA 70 for installation within the United States, or as specified in section 19-152 of Canadian Electrical Code for installation in Canada.

METER INSTALLATION

Slide the panel gasket over the rear of the unit to the back of the bezel. The unit should be installed fully assembled. Insert the unit into the panel cutout.

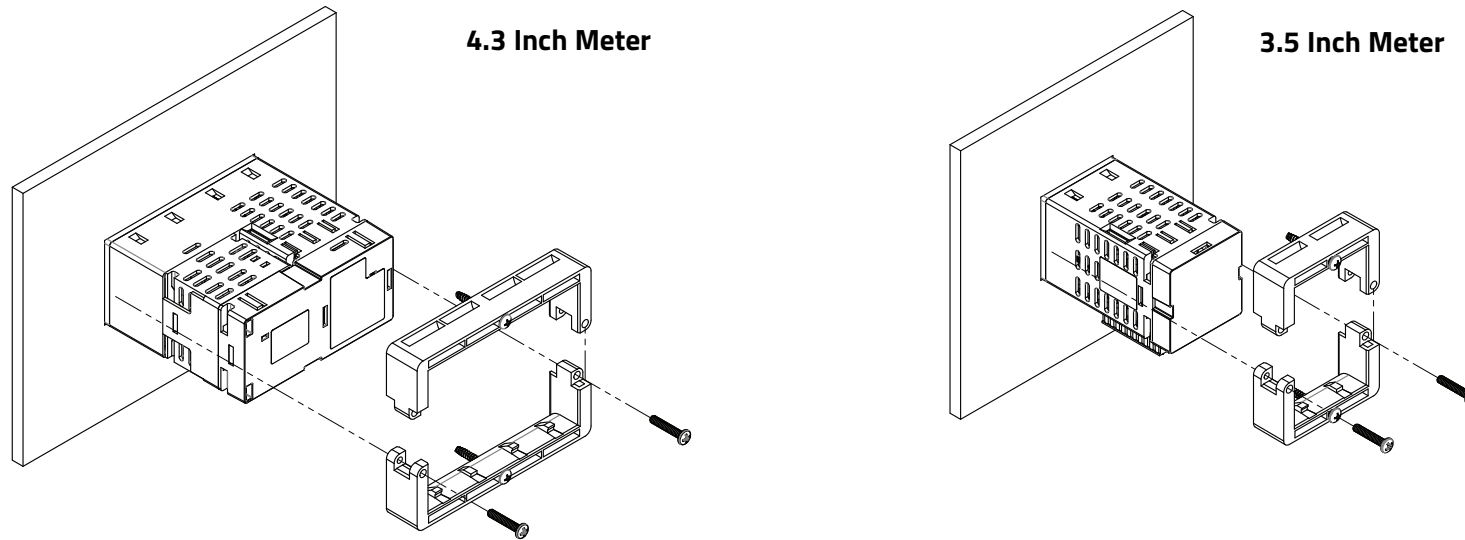

While holding the unit in place, place either the top or bottom panel latch on the rear of the unit closest to the panel cutout so that the tabs of the panel latch engage in the slots on the case. Repeat this process with the other half of the panel latch. Secure the latch with the panel mounting screws provided. To achieve a proper seal, tighten the latch screws evenly until the unit is snug in the panel (Torque to approximately 5 in-lbs [56 N-cm]). Do not over-tighten the screws.

Adding Modules



WARNING - Disconnect all power to the unit before installing or removing modules.

AVERTISSEMENT - Débranchez l'alimentation électrique de l'appareil avant d'installer ou de retirer des modules.

Installation of the product must comply with National Electrical Code (NEC), NFPA-70 or Canadian Electrical Code (CED) or any local regulation Authority.

To a 4.3 inch Host

1. To install a module on the tall side of a 4.3 inch host, align the latches of the module with the host case such that the backplane connector shroud on the module cover aligns with the backplane connector opening in the host case.
2. To install a module on the short side of a 4.3 inch host, rotate the module 180 degrees and align the latches on the host with the module case so that the I/O connector is facing downward.
3. Insert the host latches into the openings in the module case by slightly deflecting the latches inward.
4. Press the module into the host case evenly until the latches engage.
5. Install Module Locks between each module as shown by fully inserting the legs of the Module Locks into the slots in the case until the button on the Module Lock aligns with the hole provided in the case. Press fit the button into the hole. Repeat this installation between each module in your system to provide the most secure installation.
6. When you have finished adding modules, the rear cover should be installed in the same manner as the modules.



It is recommended that a relay module be installed in Module Position 1 only (shown below).

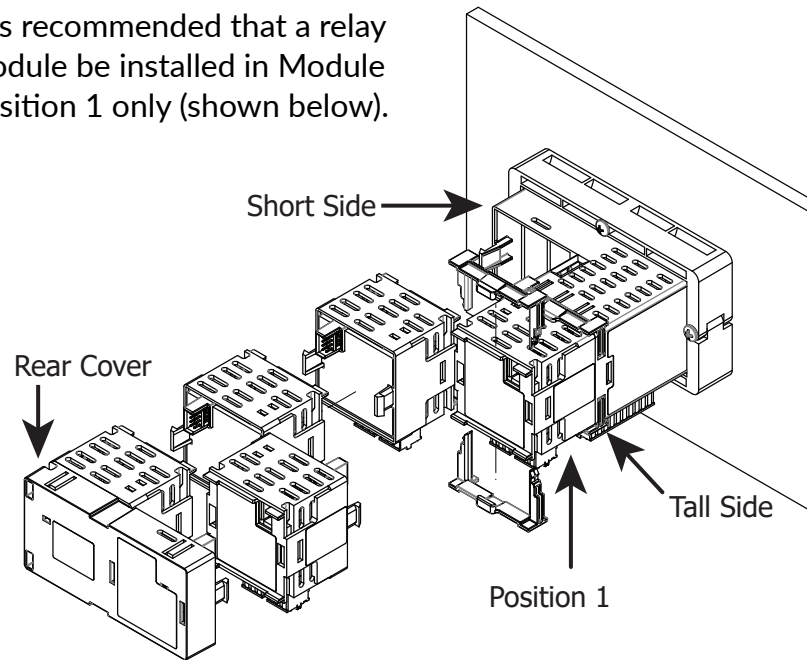

Note: When using the AC/DC module or the Spacer Module, they must be in the last position.

Module Installation Variations for 4.3 Inch (1/8 DIN) PM-50

The modules can be installed in various locations as shown below. Some installations require the Rear Interconnect Cover and Spacer Module (P/N - PMM000CP00800000). The cover connects the communication to the modules and may shorten the depth of the overall installation. A maximum of 5 modules may be connected.

Single Module Installation - Top View

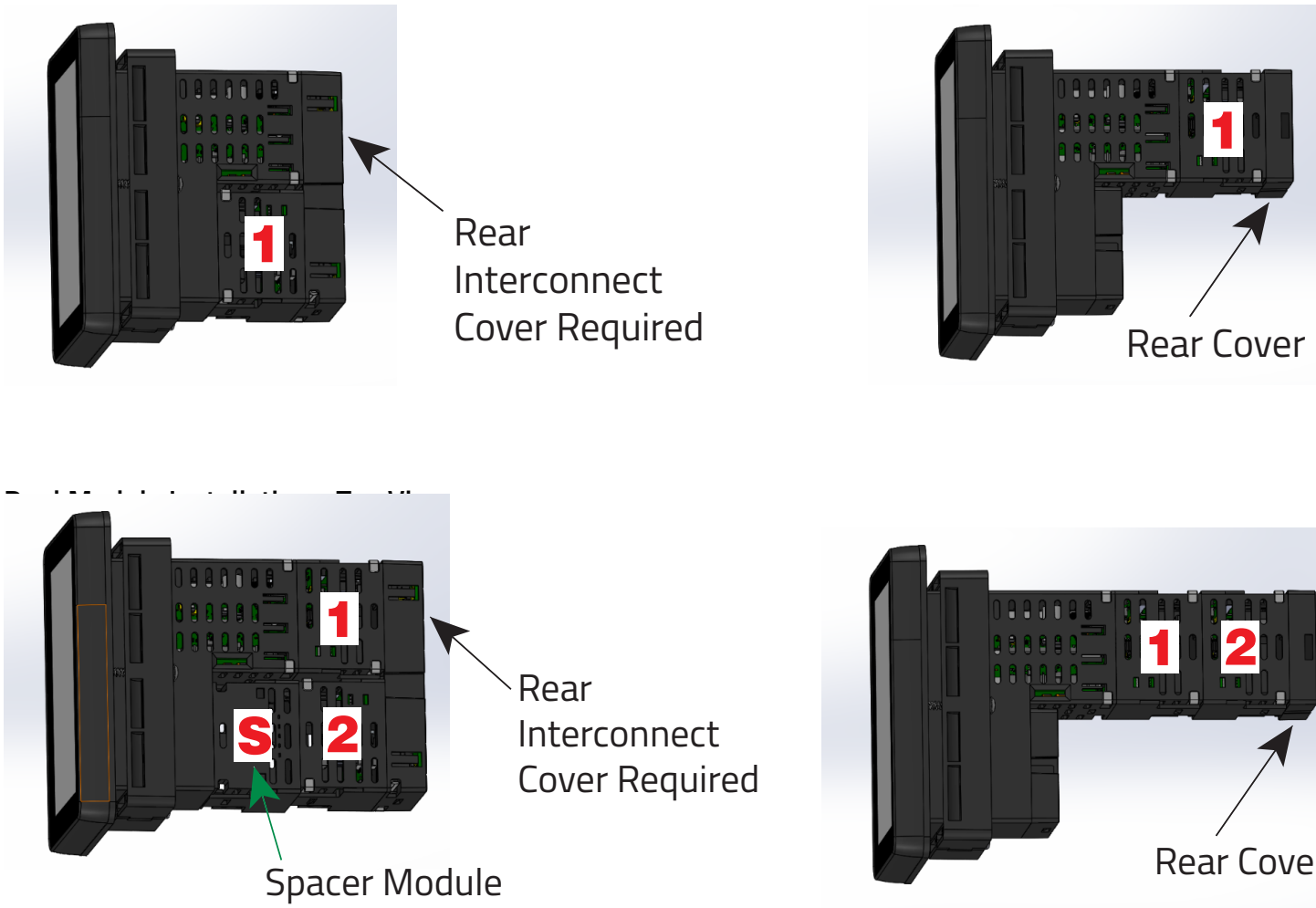

Five Module Installation - Top View

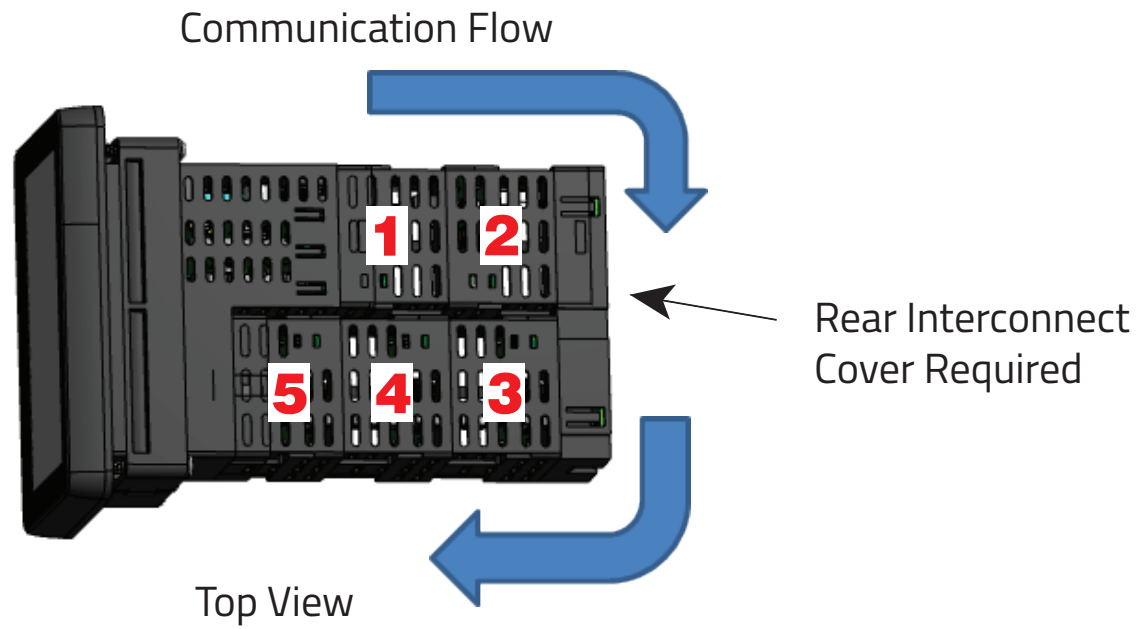

To a 3.5 inch Host

1. Align the latches of the module with the host case such that the backplane connector shroud on the module cover aligns with the backplane connector opening in the host case.
2. Insert the module latches into the openings in the host case by slightly deflecting the latches inward.
3. Press the module into the host case evenly until the latches engage.
4. Install Module Locks between each module as shown by fully inserting the legs of the Module Locks into the slots in the case until the button on the Module Lock aligns with the hole provided in the case. Press fit the button into the hole. Repeat this installation between each module in your system to provide the most secure installation.
5. When you have finished adding modules, the rear cover should be installed in the same manner as the modules.



It is recommended that a relay module be installed directly onto the back of the host (shown below), not on the back of any other module.

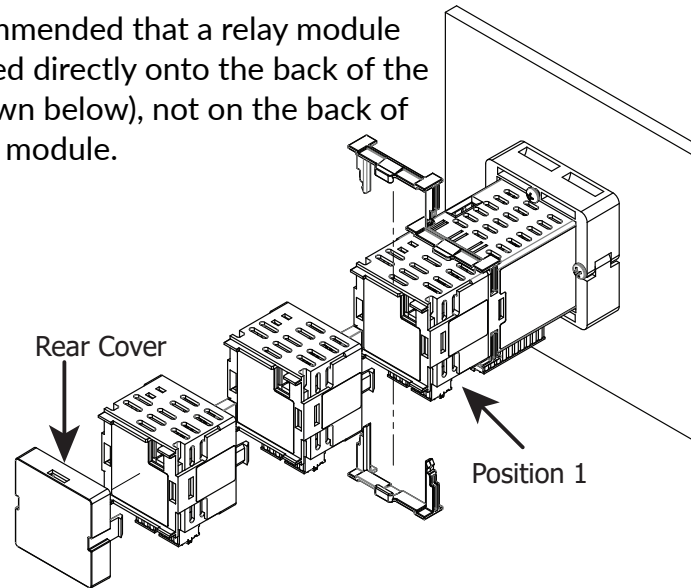

Note: When using the AC/DC module, it must be in the last position.

Wiring

All power, input and output (I/O) wiring must be in accordance with Class I, Division 2 wiring methods and in accordance with the authority having jurisdiction. Electrical connections are made via pluggable spring terminal blocks. It is recommended that the power supplied to the meter be protected by a fuse or circuit breaker.

When wiring the meter, refer to the label on the unit for pin-out numbering against those shown in the wiring drawings for proper wire position. Strip and connect the wire according to the terminal block specifications. Use a small screwdriver to press down on tab next to the terminal position to open the spring clamp. Insert the wire into the terminal position and then remove the screwdriver to engage the spring-clamp.

Power Wiring

Must use a Class 2 circuit according to National Electrical Code (NEC), NFPA-70 or Canadian Electrical Code (CEC), Part I, C22.1 or a Limited Power Supply (LPS) according to IEC/EN 60950-1 or Limited-energy circuit according to IEC/EN 61010-1.

DC Power

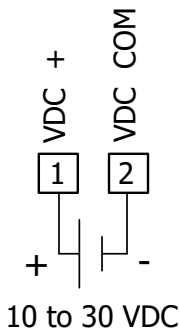

CAUTION: Sensor input common is NOT isolated from user input common. In order to preserve the safety of the controller application, the sensor input common must be suitably isolated from hazardous live earth referenced voltages; or input common must be at protective earth ground potential. If not, hazardous live voltage may be present at the User Inputs and User Input Common terminals. Appropriate considerations must then be given to the potential of the user input common with respect to earth common, and the common of the isolated plug-in modules with respect to input common.

IMPORTANT: Before connecting signal wires, verify input range and excitation is set for proper type.

VOLTAGE INPUT WIRING

Voltage Input Signal

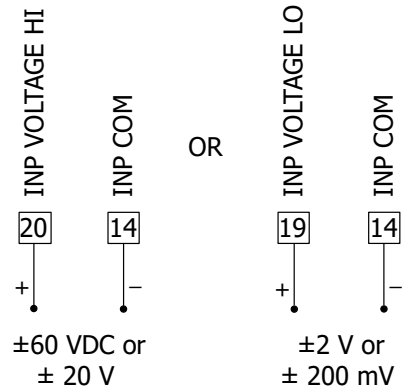

Voltage Input Signal (3 wire requiring excitation)

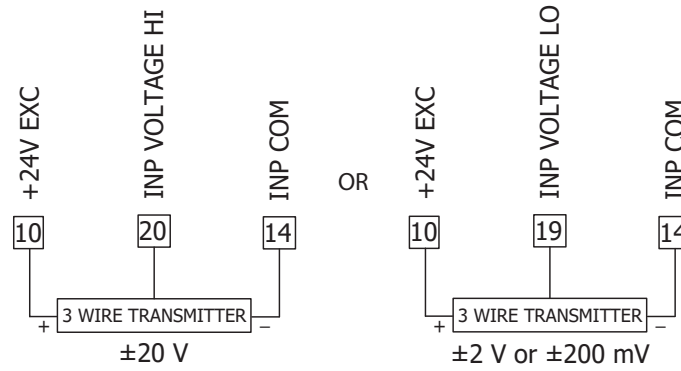

Process/Current Signal (external powered)

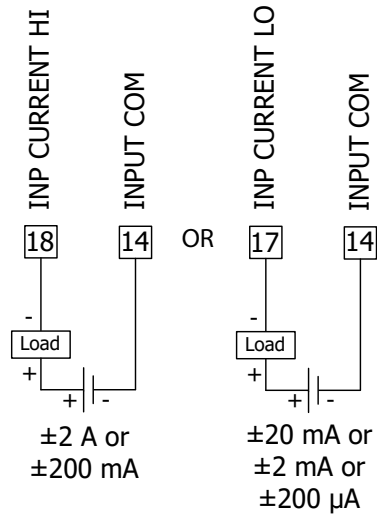

Process/Current Signal (2 wire requiring excitation)

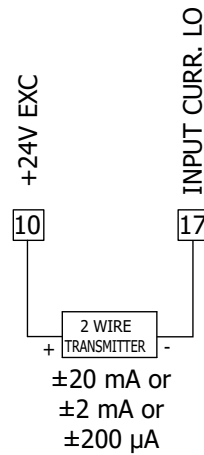

Process/Current Signal (3 wire requiring excitation)

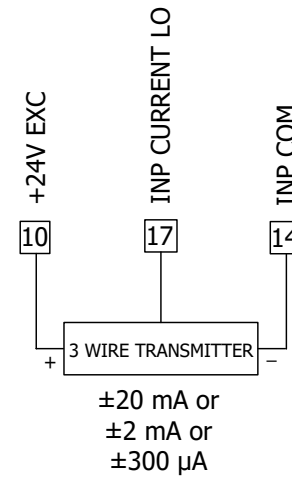

TEMPERATURE INPUT WIRING

Thermocouple



3-Wire RTD

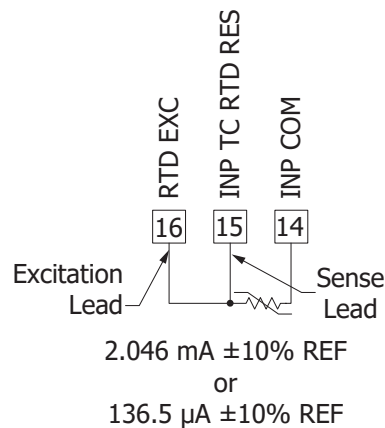

2-Wire RTD

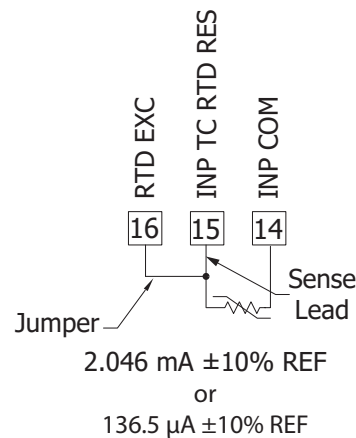

RESISTANCE WIRING

Resistance Signal (3 wire requiring excitation)

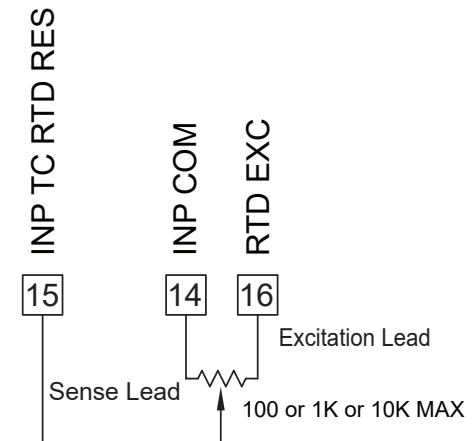

USER INPUT WIRING

User Input terminal does not need to be wired in order to remain in the inactive state.

Sinking Logic

When the parameter is programmed to Low, check with device GUI option. The user inputs of the controller are internally pulled up to +3.3 V with 20 K Ω resistance. The input is active when it is pulled low (<0.9 V).

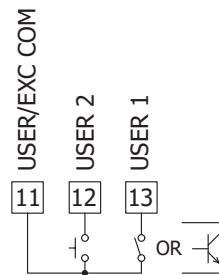

Sourcing Logic

When the parameter is programmed to High, check with device GUI option. The user inputs of the controller are internally pulled down to 0 V with 20 K Ω resistance. The input is active when a voltage greater than 2.4 VDC is applied.

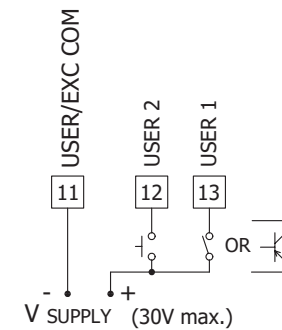

ON-BOARD DUAL SSR WIRING

The SSR outputs require meter configuration to address their functionality. The drawings below illustrate the wiring for each option.

Sinking Mode

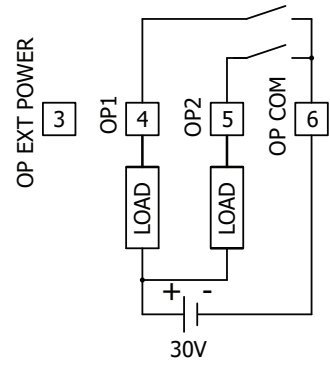

100 mA PER OUTPUT
SSR OUTPUTS SINKING MODE

Sourcing Mode

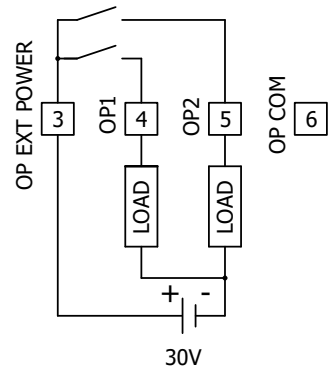

100 mA PER OUTPUT
SSR OUTPUTS SOURCING MODE

RS485/MODBUS

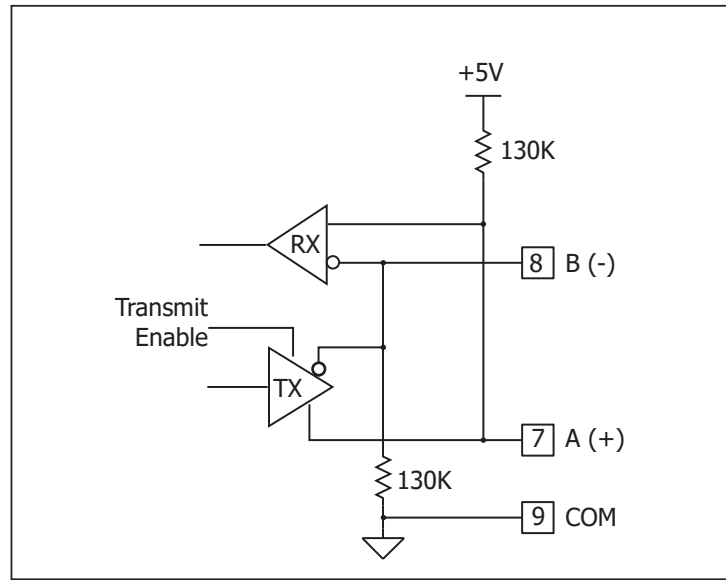

Service and Support Information

Service Information

We sincerely hope that you never experience a problem with any of our products. If you do need service, call Red Lion at 1-877-432-9908 for Technical Support. A trained specialist will help you determine the source of the problem. Many problems are easily resolved with a single phone call. If it is necessary to return a unit to us, an RO (Repair Order) can be obtained on the Red Lion website.

Red Lion tracks the flow of returned material with our RO system to ensure speedy service. You must include this RO number on the outside of the box so that your return can be processed immediately.

Be sure to have your original purchase order number and date purchased available.

We suggest that you give us a repair purchase order number in case the repair is not covered under our warranty. You will not be billed if the repair is covered under warranty.

Please supply us with as many details about the problem as you can. The information you supply will be written on the RO form and supplied to the repair department before your unit arrives. This helps us to provide you with the best service, in the fastest manner. Repairs are completed as soon as possible. If you need a quicker turnaround, ship the unit to us by air freight. We give priority service to equipment that arrives by overnight delivery.

We apologize for any inconvenience that the need for repair may cause you. We hope that our rapid service meets your needs. If you have any suggestions to help us improve our service, please give us a call. We appreciate your ideas and will respond to them.

Product Support

Technical Support:

Inside US: +1 (877) 432-9908

Outside US: +1 (717) 767-6511

Support: support.redlion.net

Hours: 8:00 am to 6:00 pm EST

Corporate Headquarters

Red Lion Controls

1750 5th Avenue

York, PA 17403

Website: www.redlion.net

LIMITED WARRANTY

(a) Red Lion Controls Inc. (the "Company") warrants that all Products shall be free from defects in material and workmanship under normal use for the period of time provided in "Statement of Warranty Periods" (available at www.redlion.net) current at the time of shipment of the Products (the "Warranty Period"). **EXCEPT FOR THE ABOVE-STATED WARRANTY, COMPANY MAKES NO WARRANTY WHATSOEVER WITH RESPECT TO THE PRODUCTS, INCLUDING ANY (A) WARRANTY OF MERCHANTABILITY; (B) WARRANTY OF FITNESS FOR A PARTICULAR PURPOSE; OR (C) WARRANTY AGAINST INFRINGEMENT OF INTELLECTUAL PROPERTY RIGHTS OF A THIRD PARTY; WHETHER EXPRESS OR IMPLIED BY LAW, COURSE OF DEALING, COURSE OF PERFORMANCE, USAGE OF TRADE OR OTHERWISE.** Customer shall be responsible for determining that a Product is suitable for Customer's use and that such use complies with any applicable local, state or federal law.

(b) The Company shall not be liable for a breach of the warranty set forth in paragraph (a) if (i) the defect is a result of Customer's failure to store, install, commission or maintain the Product according to specifications; (ii) Customer alters or repairs such Product without the prior written consent of Company.

(c) Subject to paragraph (b), with respect to any such Product during the Warranty Period, Company shall, in its sole discretion, either (i) repair or replace the Product; or (ii) credit or refund the price of Product provided that, if Company so requests, Customer shall, at Company's expense, return such Product to Company.

(d) **THE REMEDIES SET FORTH IN PARAGRAPH (c) SHALL BE THE CUSTOMER'S SOLE AND EXCLUSIVE REMEDY AND COMPANY'S ENTIRE LIABILITY FOR ANY BREACH OF THE LIMITED WARRANTY SET FORTH IN PARAGRAPH (a).**

BY INSTALLING THIS PRODUCT, YOU AGREE TO THE TERMS OF THIS WARRANTY, AS WELL AS ALL OTHER DISCLAIMERS AND WARRANTIES IN THIS DOCUMENT.