

FLEXEDGE® PID Single Loop and Dual Loop Modules



FLEXEDGE® Intelligent Edge Automation Platform

The single (1PID) and dual (2PID) loop PID control modules are designed for use with the FlexEdge DA70 controller and control applications, including virtually any combination of time proportioning or linear control for heat, cool, or heat/cool applications.

- Dedicated single and dual PID modules for the DA70
- Auto addressing minimizes configuration time
- Fully isolated design provides reliable operation
- PID control with reduced overshoot
- Universal inputs accept TC, RTD, 0-10 V and 0/4-20 mA signals
- On demand auto-tuning of PID settings
- DC analog output (1PID only)
- Heater current input (optional, 2PID only) ensures detection of heater circuit failure
- Configured using Crimson® software (version 3.2 or later)



Ordering Guide

Main Unit

Part Number	Description
DAM00PDP1RA00000	DA70 Series Module, Single PID, Relay and Analog Outputs ¹
DAM00PDP1SA00000	DA70 Series Module, Single PID, SSR and Analog Outputs
DAM00PDP2R000000	DA70 Series Module, Dual PID, Relay Outputs ¹
DAM00PDP2S000000	DA70 Series Module, Dual PID, SSR Outputs
DAM00PDP2SM00000	DA70 Series Module, Dual PID, SSR and Heater Current Monitor

Accessories

Part Number	Description
CT005001	50 Amp Current Transformer (For Heater Current Models), UL Recognized component, Instrument Transformers, Inc. Part #2SFT500-0.

A listing of the entire DA70 family of products and accessories can be found at www.redlion.net.

¹ Module is not suitable for use in hazardous locations.

DA PID Single Loop and Dual Loop Modules Specifications

Specifications

Power Requirements

Power is supplied by the DA host device.

1PID Max Power: 3.3 W

2PID Max Power: 2.7 W

LEDs*

STS – RGB Status LED shows module condition.

OP1, OP2, OP3, OP4 - Indicate status of outputs 1, 2, 3, and 4
ALM, or ALM1 and ALM2 - Alarm LEDs are lit during an internal alarm condition

* Default configuration.

Memory

Non-volatile memory retains all programmable parameters.

Inputs

GENERAL:

Sample Time: 50 msec (20 Hz)

Common Mode Rejection: >110 dB, 50/60 Hz

Normal Mode Rejection: >50 dB, 50/60 Hz

Temperature Coefficient: 0.01%/°C

Step Response Time: 100 msec typ., 200 msec max

THERMOCOUPLE INPUTS:

Types: T, E, J, K, R, S, B, N, C W5/W6, mV

Input Impedance: 20 M ohm

Lead Resistance Effect: 0.25 μ V/ohm

Cold Junction Compensation: Less than ± 1 °C typical (± 1.5 °C max) over -40 to 75 °C T_{AMB}

Resolution: 0.1°

RTD INPUTS:

Type: 385, 392, 672; 2 or 3 wire

Excitation: 150 μ A

Lead Resistance: 15 ohms Max

Resolution: 1 or 0.1°

PROCESS INPUT:

Input Range: 10 V, 20 mA

Probe Break Response

Upscale drive, Input Fault Alarm bit set high, ALx LED illuminates.

Temperature Indication Accuracy

\pm (0.3% of span, +1 °C). Includes NIST conformity, cold junction effect, A/D conversion errors, temperature coefficient and linearization conformity at 23 °C after 20 minute warm up.

Isolation Level

500 Vrms @ 50/60 Hz for 1 minute between the following:

OP1	Linear Output (1PID only)
OP2	Signal Input 1 and HCM (2PID only)
OP3	Signal Input 2 and HCM (2PID only)
OP4	Power Supply Input

Communications

Provided by the DA host device

A/D Converter

16 bit resolution

Discrete Outputs

1PID: Outputs 1 and 2 available as Solid State NFET or Form A relay. Output 3 is Solid State NFET or Form C relay.

2PID: Outputs 1, 2 and 4 available as Solid State NFET or Form A relay. Output 3 is Solid State NFET or Form C relay.

Solid State Output:

Type: Switched DC, N Channel open drain MOSFET

Current Rating: 1 A max

VDS ON: 0.3 V @ 1 A

VDS MAX: 30 VDC

Offstate Leakage Current: 0.5 mA max

Form A Relay Output:

Type: N.O.

Contact Ratings:

Per Relay: 2 Amps @ 30 VDC/30 VAC at 55 °C T_{AMB}

3 Amps @ 30 VDC/30 VAC at 50 °C T_{AMB}

Life Expectancy: 200,000 cycles at maximum load rating.

(Decreasing load, increasing cycle time, and use of surge suppression such as RC snubbers increases life expectancy.)

Form C Relay Output:

Type: SPDT

Contact Ratings:

Per Relay: 1 Amp @ 30 VDC/30 VAC at 55 °C T_{AMB}

2 Amps @ 30 VDC/30 VAC at 50 °C T_{AMB}

Life Expectancy: 100,000 cycles at maximum load rating.

(Decreasing load, increasing cycle time, and use of surge suppression such as RC snubbers increases life expectancy.)

Control Modes

Control: On/Off, P, PI, or PID

Output: Time proportioning or linear (1PID only)

Cycle Time: Programmable from 0.0 to 60.0 sec

Auto-Tune: When selected, sets proportional band, integral time, derivative time values, and output dampening time

Probe Break Action: Programmable response

Sensor Fail Response: Upscale

Alarms

Modes:

Manual

Absolute High Acting

Absolute Low Acting

Deviation High Acting

Deviation Low Acting

Inside Band Acting

Outside Band Acting

Reset Action: Programmable; automatic or latched

Standby Mode: Programmable; enable or disable

Hysteresis: Programmable

Sensor Fail Response: Upscale

DA PID Single Loop and Dual Loop Modules Specifications Cont.

Analog DC Output (1PID Only)

Selectable/programmable for 0-10 VDC, 0-20 mA, or 4-20 mA

Resolution:

Voltage: 500 μ V

Current: 1 μ A

Accuracy:

0.1% of full scale (18 to 28 °C) T_{AMB}

0.2% of full scale (-40 to 75 °C) T_{AMB}

Update Time: 0.0 to 60.0 sec

Compliance (for current output only): 500 ohm max.

Minimum load (voltage output only): 10 K ohm min.

Outputs are software selectable for either 10 V or 20 mA. The output range may be field calibrated to yield approximate 10% overrange and a small underrange (negative) signal.

Heater Current Monitor Input (Optional)

Type: 300 V max, 50 A max. Single phase, full wave monitoring of load currents

Input: 100 mA max. input for use with external current transformers

Input Resistance: 5 ohms

Accuracy: \pm 3.0% full scale, 5 to 100% of range

Frequency: 50 to 400 Hz

Minimum output on time for break alarm: 350 msec

Note: To ensure isolation to SELV circuits, use a UL Listed current transformer.

Environmental

Operating Temperature Range:

Modules with Relays: -40 to 70 °C T_{AMB}

Modules with Solid-State Outputs: -40 to 75 °C T_{AMB}

Storage Temperature Range: -40 to +85 °C T_{AMB}

Shock to IEC 68-2-27: Operational 40 g (15 g, modules w/ relays)

Operating and Storage Humidity: 0 to 85% max. Relative humidity, non-condensing.

Altitude: Up to 2000 meters

Certification & Compliance

CE Approved

EN 61326-1 Immunity to Industrial Locations

Emission CISPR 11 Class A

IEC/EN 61010-1

RoHS Compliant

ATEX Approved (DAM00PDP1SA00000, DAM00PDP2S000000, and DAM00PDP2SM00000 Only)

Ⓜ II 3 G Ex ec IIC T4 Gc

DEMKO 20 ATEX 2268X

IECEx Approved (DAM00PDP1SA00000, DAM00PDP2S000000, and DAM00PDP2SM00000 Only)

IECEx UL 20.0007X

UKEX Approved (DAM00PDP1SA00000, DAM00PDP2S000000, and DAM00PDP2SM00000 Only)

UL22UKEX2576X

UL Hazardous: File #E317425

Rugged IP30 enclosure

ABS Type Approval for Shipboard Applications

Construction

Metal and plastic enclosure with IP30 rating.

Weight: 11.1 oz (315 g)

Connections

Wire Strip Length: 0.3" (7.5 mm)

Wire Gauge Capacity: 14 to 24 AWG (2.08 to 0.20 mm²) copper wire only

Mounting

DIN Rail: Attaches to standard "T" profile DIN rail according to EN50022 - 35 x 7.5 and 35 x 15

Warranty

3 years on design and manufacturing defects.

Specifications are subject to change.

Visit www.redlion.net for more information.

DA PID Single Loop and Dual Loop Modules Dimensions

Dimensions In inches [mm]

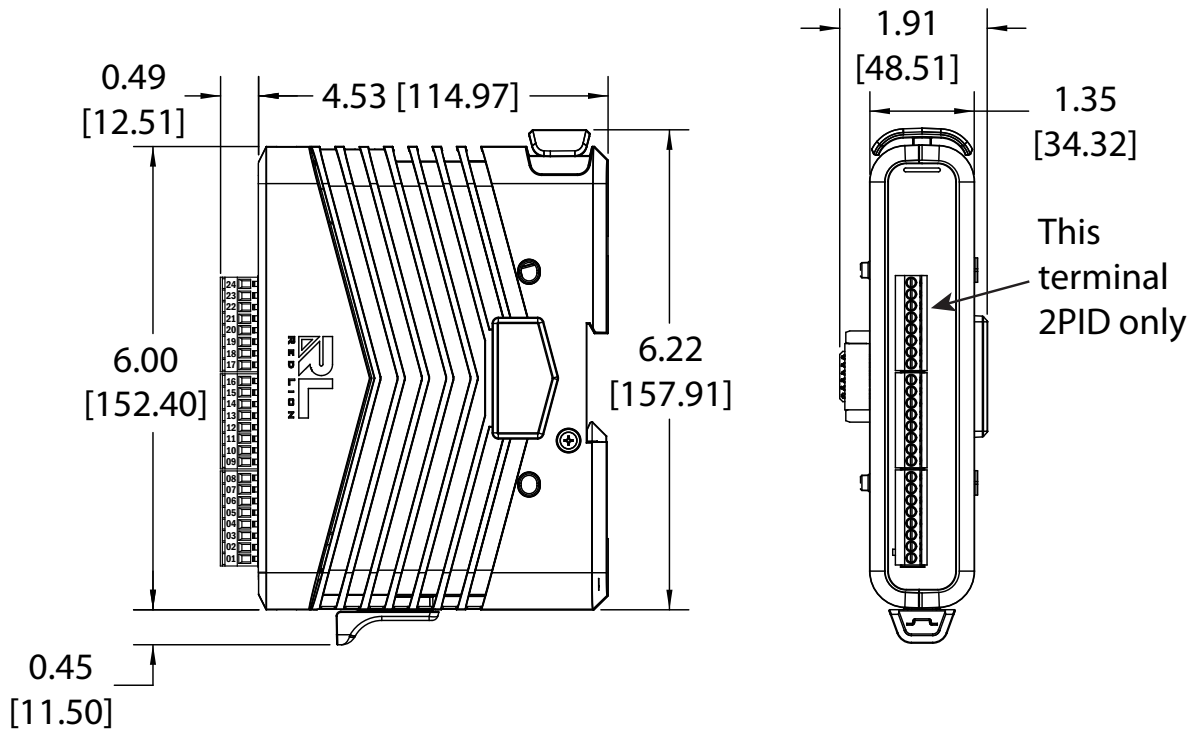

www.redlion.net
[contact us](#)

© 2024 Red Lion Controls, Inc. All Rights Reserved. The terms Red Lion, the Red Lion logo, Crimson and FlexEdge are registered trademarks of Red Lion Controls. All other marks are the property of their respective owners.

LD1109C 09 2024