

# FLEXEDGE™ DA70A 3 - Sled Modular IIoT Gateway W/ Scalable I/O



## FLEXEDGE™ Intelligent Edge Automation Platform

Red Lion's DA70A is an all-in-one industrial data acquisition and edge processing gateway that simplifies the monitoring and management of connected assets and processes

- Modular architecture to easily add cellular, Wi-Fi, serial, or USB connectivity
- Easily add up to 10 I/O modules including: analog I/O, digital I/O, universal input, relays and PID control
- Powerful networking at the core including: routing, NAT, VPN and stateful firewall
- Gateways can be upgraded to support protocol conversion, advanced automation features and Crimson Control (IEC 61131-3)
- Supports up to 10 simultaneous protocol conversions between over 300 industrial drivers (optional)
- Real-time logging to microSD card, USB drive, or FTP (optional)
- Industrial construction for reliable operation with intuitive LED status ring
- HDMI™-enabled option (Group 3/4 only)



## Ordering Guide

### Main Unit

Part Number	Description	SW Group
DA70A0FNNNNNN010	3-Sled 2 RS232 ports and 1 RS485 port Networking Gateway	Group 1
DA70A0FNNNNNN020	3-Sled 2 RS232 ports and 1 RS485 port Protocol Gateway	Group 2
DA70A0FNNNNNN030	3-Sled 2 RS232 ports and 1 RS485 port Adv IIoT Gateway	Group 3
DA70A0FNNNNNN040	3-Sled 2 RS232 ports and 1 RS485 port Adv Automation Controller	Group 4
DA70A0GNNNNNN010	3-Sled 1 RS232 port and 2 RS485 ports Networking Gateway	Group 1
DA70A0GNNNNNN020	3-Sled 1 RS232 port and 2 RS485 ports Protocol Gateway	Group 2

# DA70A Ordering Guide Continued

Part Number	Description	SW Group
DA70A0GNNNNNN030	3-Sled 1 RS232 port and 2 RS485 ports Adv IIoT Gateway	Group 3
DA70A0GNNNNNN040	3-Sled 1 RS232 port and 2 RS485 ports Adv Automation Controller	Group 4
DA70A1FNNNNNN030	3-Sled 2 RS232 ports and 1 RS485 port Adv IIoT Gateway With HDMI	Group 3
DA70A1FNNNNNN040	3-Sled 2 RS232 ports and 1 RS485 port Adv Automation Controller With HDMI	Group 4
DA70A1GNNNNNN030	3-Sled 1 RS232 port and 2 RS485 ports Adv IIoT Gateway With HDMI	Group 3
DA70A1GNNNNNN040	3-Sled 1 RS232 port and 2 RS485 ports Adv Automation Controller With HDMI	Group 4

## Accessories

Part Number	Description
<b>Sleds</b>	
DAS00CL9C1SAZ000	4G LTE (CAT1) Cellular Sled for AUS (Telstra)
DAS00CL9C4SAM000	4G LTE (CAT4) Cellular Sled for AMER (AT&T, Generic)
DAS00CL9C4SEU000	4G LTE (CAT4) Cellular Sled for EMEA, SAARC, APAC
DAS00CL9C4SVZ000	4G LTE (CAT4) Cellular Sled for AMER (Verizon)
DAS00PN1EE200000	Dual Ethernet Sled
DAS00PN2221IS000	Dual RS232 Ports Sled (Isolated)
DAS00PN2442IS000	Dual RS485 Ports Sled (Isolated)
DAS00PN2245IS000	Mixed RS232/RS485 Ports Sled (Isolated)
DAS00PN40U400000	1 Port USB 2.0 Host Sled
DAS00PN8CA6IS000	DA Series, CAN Protocol Interface Sled
DAS00PN8J16IS000	DA Series, J1939 Protocol Interface Sled
DAS00WF10N0AM000	802.11n Wi-Fi Sled
<b>Modules</b>	
DAM00I00UT8I0000	DA 8 Analog Output Module
DAM00I02C0000000	DA Series I/O Module High-Speed Rate Counter
DAM00I0DI0000000	DA 8 Channel DI/ 8 Channel DO Module
DAM00I0DI0R00000	DA 8 Channel DI/ 8 Channel RO Module
DAM00I0IN4DA0000	DA Series I/O Mix Module with 4UI
DAM00I0IN2DA0000	DA Series I/O Mix Module with 2UI
DAM00I0UIN6I0000	DA 6 Universal Isolated Input Module
DAM00PDP1RA00000	DA70 Series Module, Single PID, Relay and Analog Outputs
DAM00PDP1SA00000	DA70 Series Module, Single PID, SSR and Analog Outputs
DAM00PDP2R000000	DA70 Series Module, Dual PID, Relay Outputs
DAM00PDP2S000000	DA70 Series Module, Dual PID, SSR Outputs
DAM00PDP2SM00000	DA70 Series Module, Dual PID, SSR and Heater Current Monitor
DAM00PDSG2RA0000	DA70 Series Module, Single Loop, Two Strain Gage Inputs, Relay and Analog Outputs
DAM00PDSG2SA0000	DA70 Series Module, Single Loop, Two Strain Gage Inputs, SSR and Analog Outputs

See software manual for details on sled operation.

## Software Groups

	Group 1 Networking	Group 2 Protocol	Group 3 Adv IIoT	Group 4 Controller
<b>Configuration</b>				
Web GUI	Y	Y	Y	Y
Crimson®	Y	Y	Y	Y
<b>Networking</b>				
Firewall	Y	Y	Y	Y
RADIUS Auth.	Y	Y	Y	Y
Routing	Y	Y	Y	Y
NAT	Y	Y	Y	Y
IP Fallback	Y	Y	Y	Y
VPN Client/Server	Y	Y	Y	Y
<b>Automation</b>				
300+ Drivers		Y	Y	Y
IIoT Connectors		Y	Y	Y
OPC UA		Y	Y	Y
SQL Sync			Y	Y
Data Logging			Y	Y
Virtual HMI			Y	Y
Advanced Web Server			Y	Y
<b>IEC Control</b>				
Crimson Control				Y

# DA70A Specifications

## Specifications

### Power Requirements

Supply Voltage: 12-24 VDC +/-15%, Class 2 source

Input Voltage	12 V	24 V
Typ. Power DA70A Only	4 W	4.5 W
Max Power DA70A Only	4.5 W	5 W
Available Power for Modules (Maximum of 10 modules)	43 W	45 W
Max Power DA70A, with Sleds & USB	16 W	17 W
Max Power DA70A with full accessories	59 W	62 W

### Battery

3 V Lithium coin cell.

### Memory

On Board User Memory: 1 GB of non-volatile Flash memory.  
Memory Card: microSD slot accepts Class 5 or better microSD cards up to 256 GB capacity. FAT32, industrial grade.

### Communication Properties

USB Device Port: One (1) Isolated USB Type B Port Complies with USB Specification 2.0 (Full Speed)

USB Host Port: One (1) USB Type A Port Complies with USB Specification 2.0 (Full Speed)

Hardware overcurrent protected (0.5 A max per port)

Ethernet Ports: Two (2) 10BaseT / 100BaseTX RJ45 ports (1500 Vrms Network Isolation)

Serial Ports: Three (3) Serial Ports with Individual Port Isolation available in these two configurations:

DA70A*F	2 - RS-232 ports (RJ12 connectors) 1 - RS-485/422 port (RJ45 connector)
DA70A*G	1 - RS-232 port (RJ12 connector) 2 - RS-485/422 ports (RJ45 connectors)

HDMI Port: HDMI™ Connector. Supports 1080p@24 Hz as specified in HDMI 1.4

Not isolated from Host.

### Environmental

Without HDMI:

Operating Temperature Range: -40 to 75 °C T<sub>AMB</sub>

Storage Temperature Range: -40 to 85 °C T<sub>AMB</sub>

With HDMI Video:

Operating Temperature Range: -20 to 75 °C T<sub>AMB</sub>

Storage Temperature Range: -20 to 85 °C T<sub>AMB</sub>

Operating and Storage Humidity: 0 to 85% max. RH non-condensing

Vibration to IEC 60068-2-6: Operational 5-500 Hz, 2 g

Shock to IEC 60068-2-27: Operational 15 g

Altitude: Up to 2000 meters

Installation Category II, Pollution Degree 2 as defined in IEC/EN 60664-1.

### Certification & Compliance

CE Approved

EN 61326-1 Immunity to Industrial Locations

Emission CISPR 11 Class A

IEC/EN 61010-1

RoHS Compliant

ATEX Approved

⊕ II 3 G Ex ec IIC T4 Gc

DEMKO 20 ATEX 2268X

IECEX Approved

IECEX UL 20.0007X

UKEX Approved

UL22UKEX2576X

UL Hazardous: File # E317425

Rugged IP30 enclosure

**ABS Type Approval for Shipboard Applications**

### Connections

Wire Strip Length: 0.3" (7.5 mm)

Wire Gauge Capacity: 12 to 24 AWG (3.31 to 0.20 mm<sup>2</sup>) copper wire only

### Construction

Metal and plastic enclosure with IP30 rating.

Weight:

Without HDMI Port: 2.156 lb (978.05 g)

With HDMI Port: 2.279 lb (1.034 Kg)

### Mounting

DIN Rail: Attaches to standard "T" profile DIN rail according to EN50022 - 35 x 7.5 and 35 x 15

### Warranty

3 years on design and manufacturing defects.

Specifications are subject to change.

Visit [www.redlion.net](http://www.redlion.net) for more information.

### Trademark Acknowledgments

The terms HDMI, HDMI High-Definition Multimedia Interface, and the HDMI Logo are trademarks or registered trademarks of HDMI Licensing Administrator, Inc

# DA70A Dimensions

## Dimensions In inches [mm]

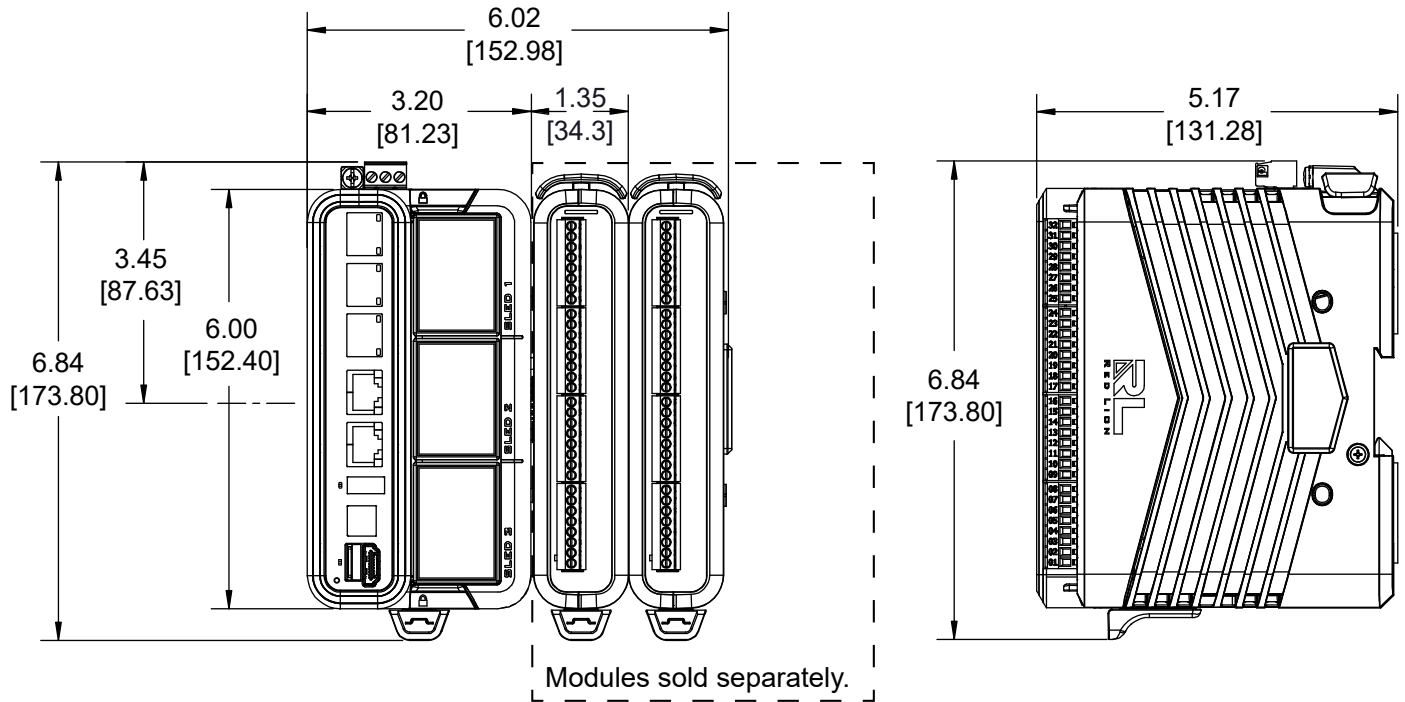

[www.redlion.net](http://www.redlion.net)  
[contact us](#)

© 2025 Red Lion Controls, Inc. All Rights Reserved. The terms Red Lion, the Red Lion logo, Crimson and FlexEdge are trademarks or registered trademarks of Red Lion Controls. All other marks are the property of their respective owners.

LD1009E 01 2025