

FLEXEDGE® 4UI / 2UI

Mix I/O Modules



FLEXEDGE® Intelligent Edge Automation Platform

One platform. Millions of configurations. Limitless potential.

- Designed for use with the DA70 controller
- Two models offering mix of inputs and outputs
4UI MIX - 4 Univ. Inputs, 3 DI/DO, 2 AO
2UI MIX - 2 Univ. Inputs, 8 DI/DO, 2 AO
- Universal inputs accept TC, RTD, 0-10 V and 0/4-20 mA signals
- Digital inputs and outputs (software selectable)
- Analog outputs capable of multiple ranges
- Configured using Crimson® software (version 3.2 or later)



Ordering Guide

Main Unit

Part Number	Description
DAM0010IN4DA0000	DA Series I/O Mix Module with 4UI
DAM0010IN2DA0000	DA Series I/O Mix Module with 2UI

A listing of the entire DA Series of products and accessories can be found at www.redlion.net.

DA 4UI / 2UI MIX I/O Modules Specifications

Specifications

Power Requirements

Power is supplied by the DA host device.

4UI MIX Max Power: 2.7 W

2UI MIX Max Power: 2.6 W

LEDs

Model dependent

STS - A status LED to show general module status

One alarm LED for each universal input channel

One LED indicator for each Digital I/O point

Memory

Non-volatile memory retains all programmable parameters. The

Controller also stores the parameters in order to reprogram any modules that need updates.

UI - Universal Inputs

GENERAL:

Sample Time: 50 msec nominal; software configurable from 4 msec to 1200 msec

Common Mode Rejection: >110 dB, 50/60 Hz

Normal Mode Rejection: >50 dB, 50/60 Hz

Temperature Coefficient: 0.01%/°C

Step Response Time: 100 msec typ., 200 msec max

THERMOCOUPLE INPUT:

Types: T, E, J, K, R, S, B, N, C W5/W6, mV

Slope & Offset: Provides sensor error correction

Input Impedance: 20 M ohm

Lead Resistance Effect: 0.25 μ V/ohm

Cold Junction Compensation: Less than ± 1 °C typical (± 1.5 °C max) over -40 to 75 °C T_{AMB}

Resolution: 0.1°

Temperature Indication Accuracy: \pm (0.3% of span, +1 °C).

Includes NIST conformity, cold junction effect, A/D conversion errors, temperature coefficient and linearization conformity at 23 °C after 20 minute warm up.

Probe Break Response: Upscale drive, Input Fault Alarm bit set high, ALM LED illuminates.

RTD INPUT:

Type: 385, 392, 672; 2 or 3 wire

Excitation: 150 μ A

Lead Resistance: 15 ohms Max

Resolution: 1 or 0.1°

Slope & Offset: Provides sensor error correction

Temperature Indication Accuracy: Includes NIST conformity, A/D conversion errors, temperature coefficient and linearization conformity at 23 °C after 20 minute warm up.

Probe Break Response: If channel is enabled: upscale drive, Input

Fault Alarm bit set high, ALM LED illuminates

CURRENT INPUT:

Ranges: 0-20 mA or 4-20 mA

Programmable Scaling: $\pm 30,000$

Input Impedance: 10 Ohm

Max. Continuous Overload: 100 mA

Accuracy: $\pm 0.1\%$ of span

Input Fault Response: Upscale Drive, Input Fault Alarm bit set high, ALM LED illuminates below -2 mA, and above 22 mA

for 0-20 mA range; below +2 mA and above 22 mA for 4-20 mA signals.

VOLTAGE INPUT:

Ranges: 0-10 VDC

Programmable Scaling: $\pm 30,000$

Input Impedance: 1 M Ohm

Max. Continuous Overload: 50 V

Accuracy: $\pm 0.1\%$ of span

Input Fault Response: Upscale Drive, Input Fault Alarm bit set high, ALM LED illuminates below -0.5 and above +10.5 VDC.

DI - DIGITAL INPUTS:

8 or 3 channels (model dependent)

Maximum Input Voltage: 30 VDC, reverse polarity protected

Guaranteed ON Voltage: 3.8 V

Guaranteed OFF Voltage: 1.2 V

Sourcing Impedance: 10K Ohm

Sinking Impedance: 20K Ohm

Selectable Hardware Filter: 50 Hz or 500 Hz

DO - DIGITAL OUTPUTS:

8 or 3 (model dependent) solid state N-channel open drain MOSFETs

Rating: 1 ADC max

V_{DS} ON: < 0.2 V @ 1 A

V_{DS} MAX: 30 VDC

Offstate Leakage Current: 0.5 μ A max

Isolation Level: 500 Vrms @ 50/60 Hz for 1 minute

AO - ANALOG OUTPUTS:

Two (2) independently configured. The outputs are not isolated from each other, but are isolated from the power supply and all other I/O.

Software programmable for 0-5 VDC, -10 VDC to 10 VDC, 0-20 mA, and 4-20 mA

Effective Resolution: Full 16-bit (Signed)

Voltage: 500 μ V

Current: 1 μ A

Accuracy: 0.2% of full scale (-40 to 70 °C)

Isolation Level: 500 Vrms @ 50/60 Hz for 1 minute

Communications

Provided by the DA70 Controller

Environmental

Operating Temperature Range: -40 to 75 °C T_{AMB}

Storage Temperature Range: -40 to 85 °C T_{AMB}

Operating and Storage Humidity: 0 to 85% max. RH non-condensing

Vibration to IEC 60068-2-6: Operational 5-500 Hz, 2 g

Shock to IEC 60068-2-27: Operational 15 g

Altitude: Up to 2000 meters

Installation Category II, Pollution Degree 2 as defined in IEC/EN 60664-1.

Certification & Compliance

CE Approved

EN 61326-1 Immunity to Industrial Locations

Emission CISPR 11 Class A

IEC/EN 61010-1

RoHS Compliant

DA 4UI / 2UI MIX I/O Modules Specifications Cont. and Dimensions

ATEX Approved

II 3 G Ex ec IIC T4 Gc
DEMKO 20 ATEX 2268X

IECEX Approved

IECEX UL 20.0007X

UKEX Approved

UL22UKEX2576X

UL Hazardous: File # E317425

Rugged IP30 enclosure

ABS Type Approval for Shipboard Applications

Connections

Wire Strip Length: 0.3" (7.5 mm)

Wire Gauge Capacity: 14 to 24 AWG (2.08 to 0.20 mm²) copper wire only

Construction

Plastic enclosure with IP30 rating.

Weight:

4UI Mix - 11.5 oz (326 g)

2UI Mix - 11.3 oz (320 g)

Mounting

DIN Rail: Attaches to standard "T" profile DIN rail according to EN50022 - 35 x 7.5 and 35 x 15

Warranty

3 years on design and manufacturing defects.

Specifications are subject to change.

Visit www.redlion.net for more information.

Dimensions In inches [mm]

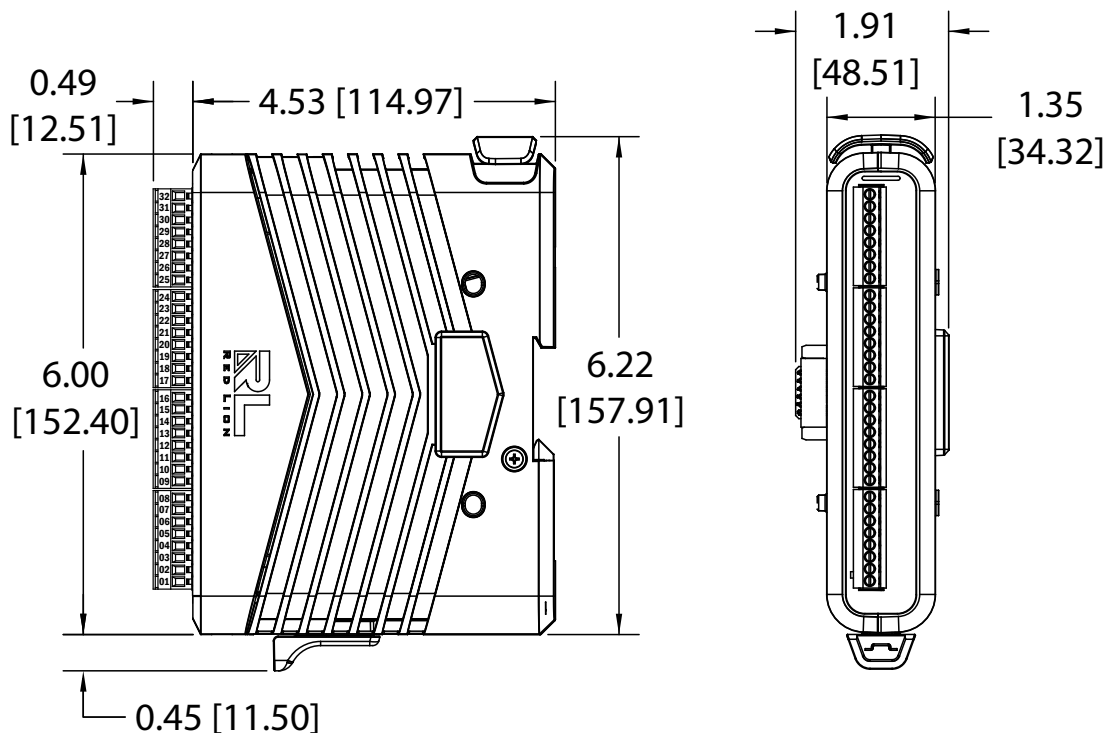



www.redlion.net
[contact us](#)

© 2024 Red Lion Controls, Inc. All Rights Reserved. The terms Red Lion, the Red Lion logo, Crimson and FlexEdge are registered trademarks of Red Lion Controls. All other marks are the property of their respective owners.

LD1013D 07 2024