

## DA Strain Gage Module Installation Guide

- Strain Gage module for the DA70
- PID control with reduced overshoot
- Load Cell, Pressure and Torque bridge inputs
- Software selectable low level inputs (20 mV, 33 mV or 200 mV full scale)
- Software selectable 5 VDC or 10 VDC bridge excitation
- Digital Tare (re-zero), Batch Totalizer, and Peak/Valley (max/min) recording
- On demand auto-tuning of PID settings
- DC analog output
- Auto addressing minimizes configuration time
- Fully isolated design provides reliable operation
- Configured using Crimson® software (version 3.2 or later)



FOR USE IN HAZARDOUS LOCATIONS:  
Class I, Division 2, Groups A, B, C, and D  
T4



II 3 G Ex ec IIC T4 Gc  
-40°C ≤ T<sub>AMB</sub> ≤ 75°C  
DEMKO 20 ATEX 2268X  
IECEx UL 20.0007X  
UL22UKEX2576X

**DAM00PDSG2RA0000 Relay Module is not suitable for use in ATEX locations**

### MODULE PACKAGE CHECKLIST

This product package should contain the items listed below. If any items are missing or damaged, contact Red Lion immediately.

- DIN rail mount DA Strain Gage Module
- Installation Guide

### GENERAL DESCRIPTION

The DA Strain Gage module is a full featured single loop PID controller designed for use with the DA70 controllers. The module accepts low level signals from a variety of bridge-type transducers, such as load cells, pressure transducers, torque transducers, etc. The second signal input provides math capabilities between the two input channels (average, differential, etc.). Each input channel provides a software selectable 5 V or 10 V stable bridge excitation voltage, capable of driving up to four 350 W bridges (combined total per module). The inputs are software selectable for ±20 mV, ±33 mV, or ±200 mV full scale.

### DIMENSIONS In inches [mm]

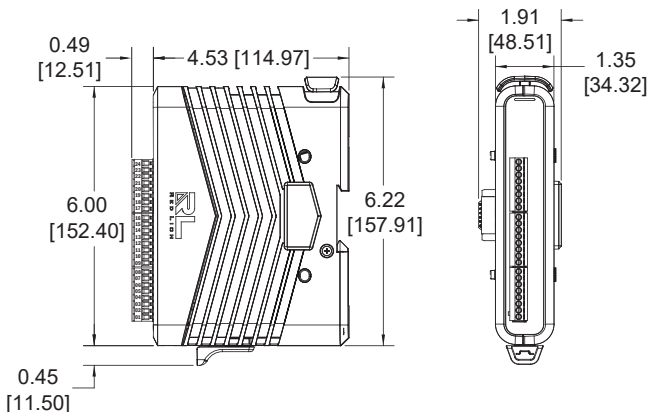

With solid state or relay outputs, plus an analog output, the DA Strain Gage module can perform virtually any combination of time-proportioning or linear control. The discrete outputs may also be assigned to one of seven internal soft alarms; and the linear output can be assigned to transmit virtually any internal variable. In addition, digital tare (re-zero), batch totalizer, and peak/valley (max/min) are provided.

The DA Strain Gage modules are available with relays, or open drain MOSFET outputs. For applications requiring large loads to be controlled, several DIN rail mount relays are available.

The modules connect and communicate via proprietary backplane to the DA host device. The DA host device, equipped with serial ports as well as an Ethernet port(s), allows the system to share data with PCs, PLCs, and SCADA systems.

Caution should be used when adding modules to the DA70 controllers. Some modules, depending on usage, may consume high levels of power. This may limit the total number of modules that can be installed on a single DA host. Check the DA module and DA host data sheets for specific usage and power requirements.

Internal power management circuits allow the module to be replaced while power is applied, which reduces downtime in the event of a relay failure. All configuration information is stored locally within the module, as well as in the Host, so replacement modules do not need to be configured.

The modules can operate in On/Off, P, PI, or PID control mode, and use an on-demand Auto-Tune that establishes the tuning constants. The PID constants may be fine-tuned through the serial or Ethernet interface. The modules employ a unique overshoot suppression feature, which allows the quickest response without excessive overshoot. The modules can also be operated in manual mode, providing the operator with direct control of the output.

## CONFIGURATION

The DA Strain Gage modules are configured with Windows® compatible Crimson® software. The software is an easy to use, graphical interface which provides a means of configuring and commissioning new systems, as well as routine module re-calibration.

## SAFETY SUMMARY

All safety related regulations, local codes as well as instructions that appear in this document or on equipment must be observed to ensure personal safety and to prevent damage to either the device or equipment connected to it.

Do not use these products to replace proper safety interlocking. No software-based device (or any other solid-state device) should ever be designed to be responsible for the maintenance of personnel safety or consequential equipment not equipped with safeguards. Red Lion disclaims any responsibility for damages, either direct or consequential, that result from the use of this equipment in a manner not consistent with these specifications.

	<b>CAUTION: Risk of Danger</b> Read complete instructions prior to installation and operation of the unit.
	<b>ATTENTION : Risque de danger</b> Lire les instructions complètes avant l'installation et l'utilisation de l'appareil.

	<b>WARNING - Explosion Hazard - Substitution of components may impair suitability for Class I, Division 2.</b>
	<b>AVERTISSEMENT - Danger d'explosion - Le remplacement de composants peut nuire à l'aptitude à la classe I, division 2.</b>

	This equipment is suitable for use in Class I, Division 2, Groups A, B, C, D, or non-hazardous locations only.
	Cet équipement est adapté à une utilisation dans des endroits de classe I, Division 2, Groupes A, B, C, D, ou dans des endroits non dangereux seulement.

	<b>WARNING - Explosion Hazard. Not hot swappable. Do not remove or replace while circuit is live unless the area is free of ignitable concentrations.</b>
	<b>AVERTISSEMENT - Risque d'explosion. Non échangeable à chaud. Ne pas retirer ou remplacer sous tension sauf si la zone est exempte de concentrations inflammables.</b>

## SPECIFICATIONS

**1. POWER:** Power is supplied by the DA host device. Modules may be hot-swapped (replaced while powered up) in non-hazardous locations only. Some modules, depending on usage may consume high levels of power. This may limit the total number of modules that can be installed on a single DA host. Check the DA module and DA host data sheets for specific usage and power requirements.

**DA Strain Gage Max Power:** 5.6 W with four 350 ohm bridges

### 2. LEDs\*:

STS - RGB Status LED shows module condition.  
OP1, OP2, OP3 - Indicate status of outputs 1, 2, and 3  
ALM - Alarm LED are lit during an internal alarm condition  
\* Default configuration.

**3. MEMORY:** Non-volatile memory retains all programmable parameters.

### 4. INPUTS:

SOFTWARE SELECTABLE INPUT RANGE	ACCURACY * 18 TO 28 °C 10 TO 75% RH	ACCURACY * 0 TO 50 °C 0 TO 85% RH	ACCURACY * -40 TO 70 °C 0 TO 85% RH
±20.000 mVDC	0.02% of reading +3 µV	0.07% of reading +4 µV	0.09% of reading +5 µV
±33.000 mVDC	0.02% of reading +5 µV	0.07% of reading +7 µV	0.09% of reading +9 µV
±200.00 mVDC	0.02% of reading +30 µV	0.07% of reading +40 µV	0.09% of reading +50 µV

\* After 20 minute warm-up. Accuracy includes the temperature coefficient.

Connection Type:

- 4-wire bridge (differential)
- 2-wire (single-ended)

Sample Time: 50 msec (20 Hz)

Common Mode Range (with respect to input common): 0 to +5 VDC

Common Mode Rejection: > 100 dB, DC to 120 Hz

Temperature Coefficient (ratio metric): 20 ppm/°C max.

Step Response Time: 100 msec typ., 200 msec max.

Input Impedance: 100 M ohm

Max Continuous Overload: 30 V

PV Range: -30,000 to 30,000

Effective Resolution: 16-bit

### 5. BRIDGE EXCITATIONS:

Software selectable:

5 VDC, ±2%, 65 mA max.

10 VDC, ±2%, 125 mA max. combined (excitation 1 plus excitation 2).

Temperature coefficient (ratio metric): 30 ppm/°C max.

Max. four 350 ohm bridges per module.

**6. ISOLATION LEVEL:** 500 Vrms @ 50/60 Hz for 1 minute between the following:

OP1 \*

OP2 \*

OP3 \*

Linear Output

Signal Input (the 2 input channels are not isolated from each other)

Power Supply Input

\* Outputs OP1, OP2 and OP3 of SSR model are not isolated from each other

**7. COMMUNICATIONS:** Provided by the DA host device

### 8. DISCRETE OUTPUTS:

Available as (3) Solid State NFET, or (3) Form A relay.

#### Solid State Output:

Type: Switched DC, N Channel open drain MOSFET

Current Rating: 1 A max

VDS ON: 0.3 V @ 1 A

VDS MAX: 30 VDC

Offstate Leakage Current: 0.5 mA max

#### Form A Relay Output:

Type: N.O.

Contact rating per relay:

1.5 Amps @ 125 VAC or 30 VDC (resistive load) at 55 °C T<sub>AMB</sub>

0.4 Amps @ 125 VAC or 30 VDC (resistive load) at 70 °C T<sub>AMB</sub>

Unloaded at 75 °C T<sub>AMB</sub>

Note: When relay contacts are connected to Mains, the Mains should be Overvoltage category II, Pollution degree 2

Life Expectancy: 200,000 cycles at maximum load rating.

(Decreasing load, increasing cycle time, and use of surge suppression such as RC snubbers increases life expectancy.)

**9. CONTROL MODES:**

- Control: On/Off, P, PI, or PID
- Output: Time proportioning or linear
- Cycle Time: Programmable from 0.0 to 60.0 sec
- Auto-Tune: When selected, sets proportional band, integral time, derivative time values, and output dampening time
- Input Fault Response: Upscale

**10. ALARMS:**

- Modes:
  - Manual
  - Absolute High Acting
  - Absolute Low Acting
  - Deviation High Acting
  - Deviation Low Acting
  - Inside Band Acting
  - Outside Band Acting
- Reset Action: Programmable; automatic or latched
- Standby Mode: Programmable; enable or disable
- Hysteresis: Programmable
- Sensor Fail Response: Upscale

**11. ANALOG DC OUTPUT:**

- Selectable/programmable for 0-10 VDC, 0-20 mA, or 4-20 mA
- Resolution:
  - Voltage: 500  $\mu$ V
  - Current: 1  $\mu$ A
- Accuracy:
  - 0.1% of full scale (18 to 28  $^{\circ}$ C)
  - 0.2% of full scale (-40 to 75  $^{\circ}$ C)
- Update Time: 0.0 to 60.0 sec
- Compliance (for current output only): 500 ohm max.
- Minimum load (voltage output only): 10 K ohm min.
- Outputs are software selectable for either 10 V or 20 mA. The output range may be field calibrated to yield approximate 10% overrange and a small underrange (negative) signal.

**12. ENVIRONMENTAL CONDITIONS:**

- Operating Temperature Range:
  - Modules with Relays: -40 to 70  $^{\circ}$ C  $T_{AMB}$
  - Modules with Solid-State Outputs: -40 to 75  $^{\circ}$ C  $T_{AMB}$

- Storage Temperature Range: -40 to +85  $^{\circ}$ C  $T_{AMB}$
- Shock to IEC 68-2-27: Operational 15 g (10 g, modules w/ relays)
- Vibration to IEC 68-2-6: Operational 5-500 Hz, 2 g
- Operating and Storage Humidity: 0 to 85% max. relative humidity, non-condensing.
- Altitude: Up to 2000 meters

**13. CERTIFICATIONS AND COMPLIANCES:**

- CE Approved**
  - EN 61326-1 Immunity to Industrial Locations
  - Emission CISPR 11 Class A
  - IEC/EN 61010-1
  - RoHS Compliant

**ATEX Approved**

- II 3 G Ex ec IIC T4 Gc
- DEMKO 20 ATEX 2268X

**IECEX Approved**

- IECEX UL 20.0007X

**UKEX Approved**

- UL22UKEX2576X

**UL Hazardous: File #E317425**

Rugged IP30 enclosure

**ABS Type Approval for Shipboard Applications**

**14. CONSTRUCTION:** Metal and plastic enclosure with IP30 rating. For use only in approved enclosure.

**15. CONNECTIONS:** Removable wire clamp screw terminal blocks

Wire Strip Length: 0.3" (7.5 mm)

Wire Gauge Capacity: 14 to 24 AWG (2.08 to 0.20 mm<sup>2</sup>) copper wire only

Torque: 2 inch-lbs (0.23 N-m)

**16. MOUNTING:** Mounts onto standard DIN style top hat (T) profile mounting rails according to EN50022 - 35 x 7.5 mm and 35 x 15 mm.

**17. WEIGHT:** 11.1 oz (315 g)

**Block Diagram**

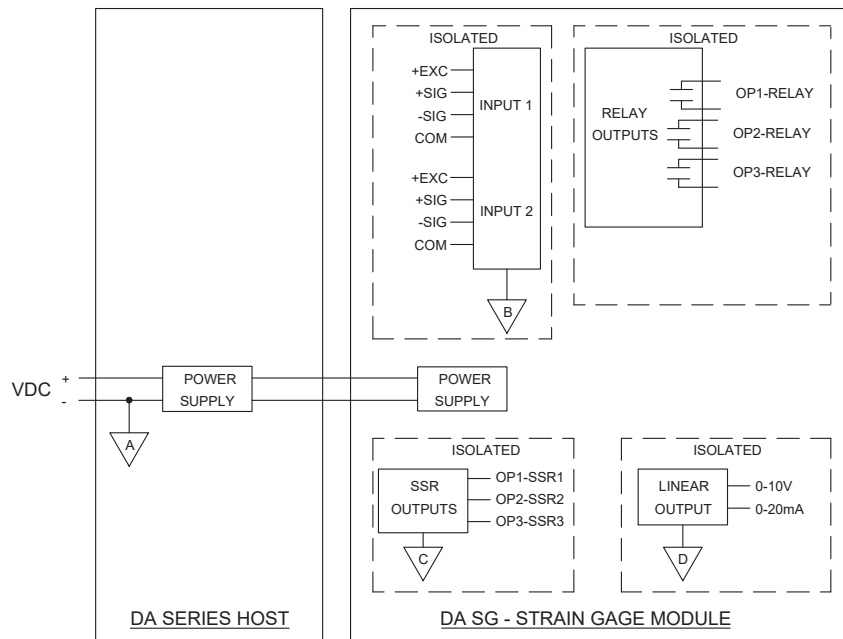

### EMC INSTALLATION GUIDELINES

Visit <https://www.redlion.net/emi> for more information on EMI guidelines, Safety and CE issues as they relate to Red Lion products.

### HARDWARE INSTALLATION

#### Removing Module From Cradle

To remove the module from the cradle, push in the module release button at the top of the cradle and pull the module out of the cradle.

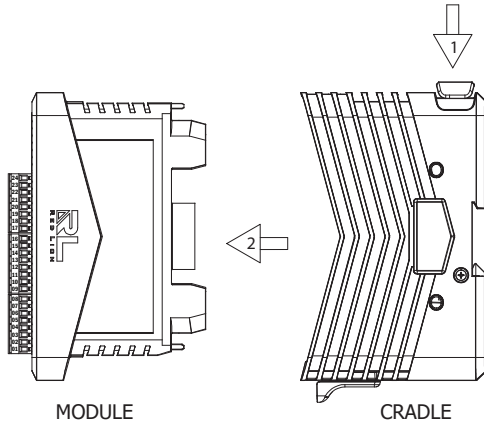

#### Installing Module into Cradle

Push module into cradle until you hear an audible click indicating it is properly latched.

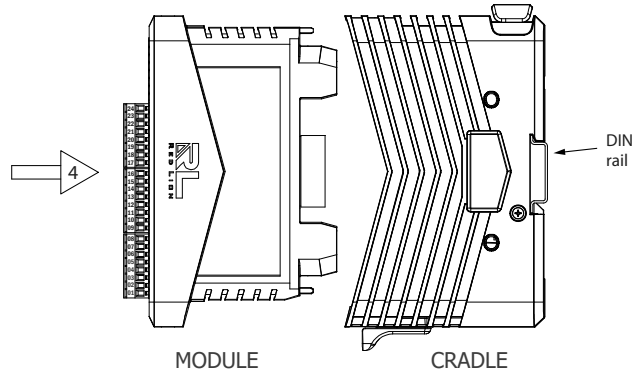

#### Attaching the Module/Cradle to the DIN Rail

The DIN rail should be mounted horizontally so that the unit's ventilation holes are vertical in relation to installation orientation. A minimum clearance of 1 inch (25.4 mm) should be maintained above and below the unit to ensure proper thermal regulation.

The cradle can be installed on the DIN rail with or without the module attached. Ensure the DIN rail lock latch is in the outward most position (unlocked). Hook the top back of the cradle DIN rail clip over the DIN rail. Press the cradle until flush with the rail and push the DIN rail lock latch to the latched (in) position.

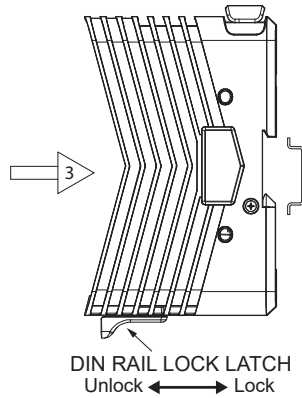

For hazardous location installation, the following shall be taken into consideration:

- The equipment shall only be used in an area of at least pollution degree 2, as defined in EN/IEC 60664-1.
- The equipment shall be installed in an enclosure that provides a minimum ingress protection of IP54 in accordance with EN/IEC 60079-0. The enclosure shall be accessible only with the use of a tool.
- Transient protection shall be provided that is set at a level not exceeding 140% of the peak rated voltage value at the supply terminals to the equipment.

### WIRING

#### Wiring Connections

All power, input and output (I/O) wiring must be in accordance with Class I, Division 2 wiring methods and in accordance with the authority having jurisdiction.

All conductors should meet voltage and current ratings for each terminal. When wiring the module, use the numbers on the label to identify the position number with the proper function. Strip the wire, leaving approximately 0.3" (7.5 mm) of bare wire exposed. Insert the wire into the terminal, and tighten.

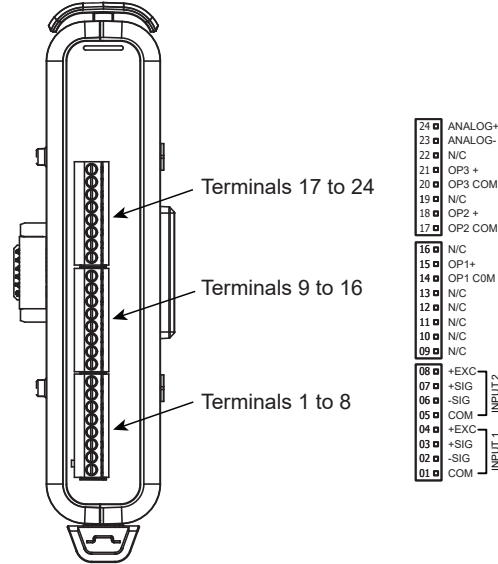

24	ANALOG+
23	ANALOG-
22	N/C
21	OP3 +
20	OP3 COM
19	N/C
18	OP2 +
17	OP2 COM
16	N/C
15	OP1+
14	OP1 COM
13	N/C
12	N/C
11	N/C
10	N/C
09	N/C
08	+EXC
07	+SIG
06	-SIG
05	COM
04	+EXC
03	+SIG
02	-SIG
01	COM

**CAUTION:** Only UL listed wiring with temperature ratings greater than 90 °C permitted for Class I, Division 2, Zone 2 and ATEX, IECex and UKEX installations.

**ATTENTION:** Seul le câblage homologué UL avec des températures nominales supérieures à 90°C est autorisé pour les installations de classe I, Division 2, zone 2 et ATEX, IECex et UKEX.

### Input Wiring

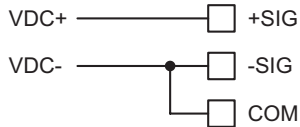

2-Wire Single Ended Input

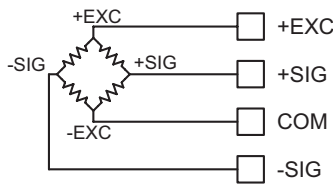

4-Wire Bridge Input

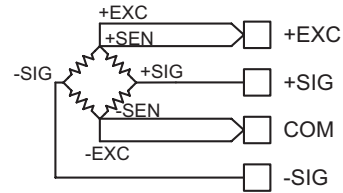

6-Wire Bridge Input

### Bridge Completion Resistors

For single strain gage applications, bridge completion resistors must be employed externally to the module. Only use metal film resistors with a low temperature coefficient of resistance.

Load cells and pressure transducers are normally implemented as full resistance bridges and do not require bridge completion resistors.

### Output Wiring

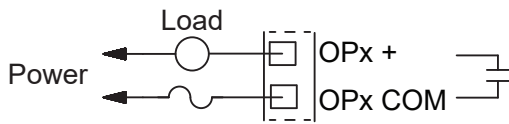

Relay Outputs

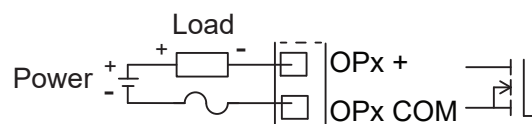

Solid State Outputs

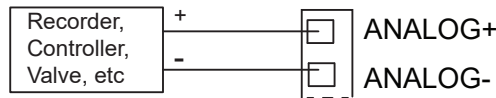

Analog Output

### LEDs

#### Status LED

The red/green/blue Status LED is located at the top of the module and provides information regarding the state of the module. This includes indication of the various stages of the start-up routine (power-up), as well as any errors that may occur.

LED COLOR(S)	MEANING
Flashing Blue	Module is booting.
Flashing Green	Module is switching to configuration.
Green	Module is performing normally.
Flashing Green/Purple	Module is performing auto calibration.
Flashing Blue/Yellow	Module is being flash upgraded by Crimson.
Flashing Red	Error: general error with module.
Flashing Red/Green	Error: module is controlling properly, but has lost communication with the Host.
Flashing Yellow	Error: no bus frequency.
Flashing Red/Green/Blue	Error: module is running the Factory Programming Console.

#### OP1, OP2, OP3 – Output Status LED

The green OP1, OP2, and OP3 LEDs are factory configured to indicate the status of the outputs. The LEDs turn on when the output is active. These LEDs may be remapped to various other module properties.

#### ALM – Alarm LED

The red Alarm LEDs indicate the presence of an alarm. Whenever one of the seven alarms is active, the LED turns on. This LED may be remapped to various other module properties.

#### FIRMWARE UPGRADE

The module's firmware is stored in flash memory so that software/ hardware conflicts are avoided, and so features can be added in the future.

During a download, Crimson compares its own library of firmware files with those stored in the module. If they do not match, Crimson will download the necessary firmware.

**RED LION CONTROLS TECHNICAL SUPPORT**

If for any reason you have trouble operating, connecting, or simply have questions concerning your new product, contact Red Lion's technical support.

Support: [support.redlion.net](http://support.redlion.net)

Website: [www.redlion.net](http://www.redlion.net)

Inside US: +1 (877) 432-9908

Outside US: +1 (717) 767-6511

Corporate Headquarters

Red Lion Controls, Inc.

1750 5<sup>th</sup> Avenue York, PA 17403

**ORDERING INFORMATION**

TYPE	DESCRIPTION	PART NUMBER
Input Modules	DA70 Series Module, Single Loop, Two Strain Gage Inputs, Relay and Analog Outputs <sup>1</sup>	DAM00PDSG2RA0000
	DA70 Series Module, Single Loop, Two Strain Gage Inputs, SSR and Analog Outputs	DAM00PDSG2SA0000

A listing of the entire DA70 family of products and accessories can be found at [www.redlion.net](http://www.redlion.net).

<sup>1</sup> Module is not suitable for use in ATEX locations.

This page intentionally left blank.

## **COPYRIGHT**

© 2024 Red Lion Controls, Inc. All Rights Reserved. The terms Red Lion, the Red Lion logo and Crimson are registered trademarks of Red Lion Controls. All other marks are the property of their respective owners.

### **LIMITED WARRANTY**

(a) Red Lion Controls Inc. (the "Company") warrants that all Products shall be free from defects in material and workmanship under normal use for the period of time provided in "Statement of Warranty Periods" (available at [www.redlion.net](http://www.redlion.net)) current at the time of shipment of the Products (the "Warranty Period"). **EXCEPT FOR THE ABOVE-STATED WARRANTY, COMPANY MAKES NO WARRANTY WHATSOEVER WITH RESPECT TO THE PRODUCTS, INCLUDING ANY (A) WARRANTY OF MERCHANTABILITY; (B) WARRANTY OF FITNESS FOR A PARTICULAR PURPOSE; OR (C) WARRANTY AGAINST INFRINGEMENT OF INTELLECTUAL PROPERTY RIGHTS OF A THIRD PARTY; WHETHER EXPRESS OR IMPLIED BY LAW, COURSE OF DEALING, COURSE OF PERFORMANCE, USAGE OF TRADE OR OTHERWISE.** Customer shall be responsible for determining that a Product is suitable for Customer's use and that such use complies with any applicable local, state or federal law.

(b) The Company shall not be liable for a breach of the warranty set forth in paragraph (a) if (i) the defect is a result of Customer's failure to store, install, commission or maintain the Product according to specifications; (ii) Customer alters or repairs such Product without the prior written consent of Company.

(c) Subject to paragraph (b), with respect to any such Product during the Warranty Period, Company shall, in its sole discretion, either (i) repair or replace the Product; or (ii) credit or refund the price of Product provided that, if Company so requests, Customer shall, at Company's expense, return such Product to Company.

(d) **THE REMEDIES SET FORTH IN PARAGRAPH (c) SHALL BE THE CUSTOMER'S SOLE AND EXCLUSIVE REMEDY AND COMPANY'S ENTIRE LIABILITY FOR ANY BREACH OF THE LIMITED WARRANTY SET FORTH IN PARAGRAPH (a).**

**BY INSTALLING THIS PRODUCT, YOU AGREE TO THE TERMS OF THIS WARRANTY, AS WELL AS ALL OTHER DISCLAIMERS AND WARRANTIES IN THIS DOCUMENT.**