

# **RL** RED LION CONTROLS

**INTERNATIONAL HEADQUARTERS**  
20 Willow Springs Circle, York, Pa. 17402, (717) 767-6511 FAX: (717) 764-0839  
Web site- <http://www.redlion-controls.com> E-mail- [sales@redlion-controls.com](mailto:sales@redlion-controls.com)

**EUROPEAN HEADQUARTERS**  
892 Plymouth Road, Slough, Berkshire SL1 4LP  
ENGLAND +44 1753 696888 FAX: +44 1753 696339

## MODEL IMY - APOLLO INTELLIGENT METER FOR THERMISTOR INPUTS

- ACCEPTS 2252  $\Omega$ , "400 SERIES" AND THERMOLINEAR™, "700 SERIES" THERMISTORS
- STATE-OF-THE-ART DIGITAL ELECTRONICS FOR GREATER ACCURACY AND RELIABILITY
- FULL 6-DIGIT, HIGH VISIBILITY, 0.56" HIGH RED LED DISPLAY
- PROGRAMMABLE FRONT PANEL LOCK-OUT MENU
- INTEGRATOR (Totalizer) (Optional)
- PEAK/VALLEY MEMORY (Optional)
- DUAL ALARM RELAY OUTPUTS (Optional)
- BI-DIRECTIONAL SERIAL COMMUNICATIONS (Optional)
- 4 to 20 mA OR 0 to 10 VDC ANALOG OUTPUT (Optional)
- NEMA 4/IP65 SEALED METAL FRONT BEZEL



### DESCRIPTION

The Apollo Intelligent Thermistor Meter (IMY) accepts standard Thermistor inputs and precisely linearizes them for temperature readings. Like an RTD, a thermistor is also a temperature sensitive resistor, but the thermistor provides a much larger resistance change per degree. Since thermistors provide a large resistance change, significant errors from long lead lengths or switches are eliminated. Other advantages of using a thermistor are accuracy, repeatability, long term stability, and sensor cost. A full 6-digit display accommodates a wide range of temperature inputs and holds large totalization values. State-of-the-art digital circuitry virtually eliminates errors due to drift. A full complement of option packages is available to support many process applications.

The IMY supports two popular thermistor series - the 400 Series 2,252 Ohm thermistor, and the 700 Series Thermoliner™ thermistor. Selection of the type is done in Programming Module #1.

The indicator features a readout choice of either Fahrenheit or Celsius with 0.1 or 1 degree of resolution. English Style display prompts and front panel buttons aid the operator through set-up and operation. A front panel lock-out menu protects set-up data and operation modes from unauthorized personnel. Programmable digital filtering enhances the stability of the reading. Remote input "E1-CON" can be utilized to control a variety of functions including, totalizing, display hold, set point and peak/valley reading operations. All set-up data is stored in E<sup>2</sup> PROM, which will hold data for a minimum of 10 years without power.

An optional integrator (*totalizer*) can be used to totalize or integrate temperatures up to a maximum display value of 999,999. It features independent scaling, decimal point selection, and a low temperature cut-out to suit a wide variety of temperature integration/totalization applications. Programmable remote input "E2-CON" is included with this option and can be utilized to control a variety of functions, such as integrating/totalizing, alarm control, peak/valley readings, display hold or temperature offset operations, simultaneously with remote input "E1-CON". Peak/valley (*max/min*) reading memory and programmable temperature offset functions are included with this option and they are easily recalled and controlled by either the front panel or a

remote input. All readings are retained at power-down.

Optional dual relays with parallel solid state outputs are fully programmable to operate in a wide variety of modes to suit many control or alarm applications.

Optional 20 mA loop, bi-directional serial communications provides computer and printer interfacing to extend the capabilities of the indicator. More than one unit can be connected in the loop with other RLC products which have serial communications capabilities.

An optional 4 to 20 mA or 0 to 10 VDC re-transmitted analog output can be scaled by the user to interface with a host of recorders, indicators and controllers. The indicator has several built-in diagnostic functions to alert operators to any malfunction. Extensive testing of noise interference mechanisms and a full burn-in make the indicator extremely reliable in industrial environments. The die-cast front bezel meets NEMA 4/IP65 requirements for washdown applications. Plug-in style terminal blocks simplify installation wiring and change-outs.

### SAFETY SUMMARY

All safety related regulations, local codes and instructions that appear in the manual or on equipment must be observed to ensure personal safety and to prevent damage to either the instrument or equipment connected to it. If equipment is used in a manner not specified by the manufacturer, the protection provided by the equipment may be impaired.

Do not use this unit to directly command motors, valves, or other actuators not equipped with safeguards. To do so, can be potentially harmful to persons or equipment in the event of a fault to the unit.

### SPECIFICATIONS

1. **DISPLAY:** 4-digit with F/C indication, 0.56" (14.2 mm) high LED, minus sign displayed for negative temperatures. 6-digits for totalizer, "Flashing" display during totalizer overflow. "OLOLOL" displayed during temperature display out of range (*positive*). "ULULUL" displayed during temperature display out of range (*negative*). "SHORT" displayed for shorted input and "ULULUL" displayed for unconnected input.

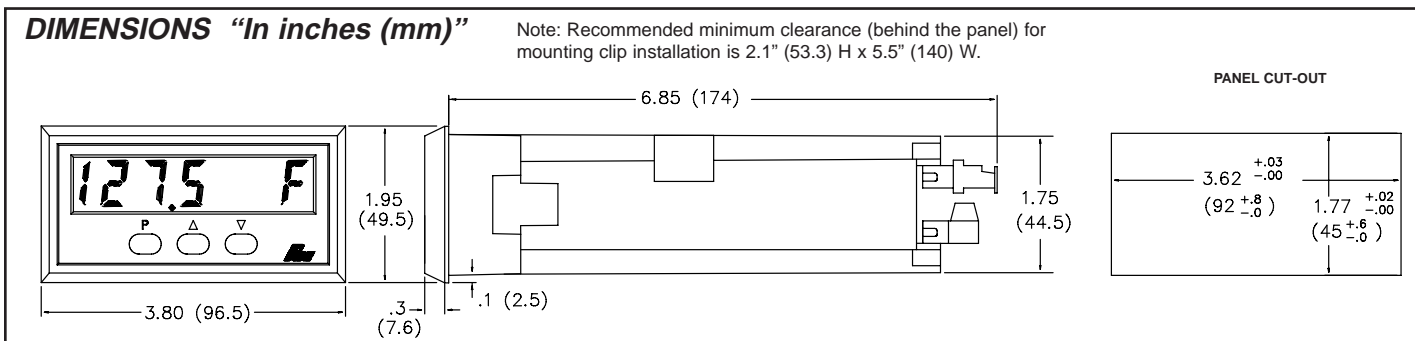

## SPECIFICATIONS (Cont'd)

### 2. POWER REQUIREMENTS:

**A.C. Power:** Switch Selectable 115/230 VAC,  $\pm 10\%$ , 50/60 Hz, 14 VA

**D.C. Power:** 10 to 30 VDC, 9 Watts max., isolated to 300 Vp.

### 3. CONTROLS:

Three front panel push buttons for modifying alarm values and indicator set-up. Three external inputs; one for disabling the front panel, and two for programmable function inputs.

### 4. SIGNAL INPUT:

2-Wire, 400 Series 2,252  $\Omega$  Thermistor; or 3-wire, 700 Series Thermoliner™ thermistor.

**Max. Input Signal Voltage:**  $\pm 15$  VDC.

### 5. OPEN THERMISTOR DETECTION:

**Display:** "ULULUL"

**Setpoint Outputs:** Disabled (Deactivated)

**Serial Outputs:** "ULULUL" in data field

**Integration/Totalization:** Disabled

**Analog Output:** 4 mA

### 6. RANGE:

400 Series -40.0° to 125.0°C (-40.0° to 257°F) 700 Series -30.0° to 100.0°C (-22.0° to 212°F).

### 7. RESOLUTION:

0.1 or 1 degree.

### 8. ACCURACY:

$\pm 0.2^\circ\text{C}$  ( $0.36^\circ\text{F}$ )  $\pm 1/2$  LSD, @ 23°C and 10 min. warm-up.

### 9. READING RATE:

2.5 readings/second

### 10. RESPONSE TIME:

2 seconds to settle for step input (increases with programmable digital filtering)

### 11. TOTALIZER:

Front panel button for input/total display select. External totalizer reset/enable. Programmable time-base, scale factor (0.001-100.000) and low-temp. cut-out. Response Time = 0.2 sec. max.

### 12. E1-CON & E2-CON:

External remote inputs that allow activation of various functions. (Reset total, peak indicator mode, trigger mode, etc.)  $V_{IL} = 0.8 V_{MAX}$ ;  $V_{IH} = 2.0 V_{MIN}$ . Response Time = 0.2 sec. max.

### 13. NORMAL MODE REJECTION:

40 dB at 50/60 Hz (may be improved by programmable digital filtering)

### 14. COMMON MODE REJECTION:

120 dB, DC to 50/60 Hz

### 15. ENVIRONMENTAL CONDITIONS:

**Operating Temperature Range:** 0 to 50°C

**Storage Temperature Range:** -40 to 80° C

**Operating and Storage Humidity:** 85% max. (non-condensing) from 0 to 50°C.

**Span Drift:** 50 ppm/°C

**Zero Drift:** 0.001°C/°C

**Altitude:** Up to 2000 meters

### 16. SERIAL COMMUNICATIONS (Optional):

**Type:** Bi-directional 20 mA current loop, 20 mA source provided on transmit loop. (Powers up to 7 units in a loop with internal current source) .

**Baud Rate:** programmable 300 to 2400

**Maximum address:** 99 (Actual number in a single loop is limited by serial hardware specifications.)

**Data Format:** 10 bit frame, Odd parity (one start bit, 7 data bits, one odd parity bit, and one stop bit.)

#### Serial Hardware Specifications:

**SO - Output Transistor Rating:**  $V_{MAX} = 30$  VDC,  $V_{SAT} = 1 V_{MAX}$  at 20 mA.

*Note: This will allow up to 28 units max. in each loop.*

**SI - Input Diode Rating:**  $V_F = 1.25 V_{TYP}$ ;  $1.5 V_{MAX}$

*Note: The compliance voltage rating of the source must be greater than the sum of the voltage drops around the loop. (Typically a 30 VDC powered source would be capable of operating between 18 and 22 units in a loop.)*

### 17. ALARMS (Optional):

**Solid State:** Two, isolated, sinking open collector NPN transistors acting in parallel with relays.  $V_{SAT} = 1 V$  @ 100 mA max.,  $V_{MAX} = 30$  VDC.

#### Relays:

**Type:** Form C (2)

**Max. Rating:** 5 Amps @ 120/240 VAC or 28 VDC (resistive load) , 1/8 hp @ 120 VAC (inductive load).

**Relay Life Expectancy:** 100,000 cycles at max. rating. (As load level decreases, life expectancy increases.)

### 18. ANALOG OUTPUT (Optional):

**4 to 20 mA:** Digital scaling and offsetting within a 4 to 20 mA range

**Accuracy:** 0.1% of full scale

**Resolution:** 12 bits

**Compliance Voltage:** 10 VDC (500  $\Omega$  max. loop resistance)

**0 to 10 VDC:** Digital scaling and offsetting within a 0 to 10 VDC range

**Accuracy:**  $\pm(0.1\%$  of reading  $+35$  mV)

**Resolution:** 12 bits

**Min. Load Resistance:** 10 K $\Omega$  (1 mA max.)

### 19. PEAK/VALLEY/SLOPE/OFFSET (Optional):

Peak and Valley recording. Programmable temperature offset and slope.

### 20. CERTIFICATIONS AND COMPLIANCES:

#### EMC EMISSIONS:

Meets EN 50081-2: Industrial Environment.

CISPR 11 Radiated and conducted emissions

#### EMC IMMUNITY:

Meets EN 50082-2: Industrial Environment.

ENV 50140 - Radio-frequency radiated electromagnetic field<sup>1</sup>

ENV 50141 - Radio-frequency conducted electromagnetic field

EN 61000-4-2 - Electrostatic discharge (ESD)<sup>2</sup>

EN 61000-4-4 - Electrical fast transient/burst (EFT)

#### Notes:

1. Unit complies with listed specifications at 10 V/m, with unit installed in a metal panel, rear of the unit covered with a metal enclosure providing at least 5 dB of shielding effectiveness and mounted to an aluminum rack connected to earth ground (protective earth). All I/O cables routed through metal conduit that is connected to earth ground at both ends.

a. Unit complies with listed specifications at 6 V/m, with unit installed in a metal panel mounted to an open aluminum rack connected to earth ground.

b. At 10 V/m, with unit installed in a metal panel mounted to the open aluminum rack, the process signal and 4 to 20 mA analog output option can vary out of range from specifications.

2. Metal bezel of unit connected with ground lead from rear bezel screw to metal mounting panel.

Refer to the EMC Compliance Installation section of the manual for additional information.

21. **CONSTRUCTION:** Die-cast metal front bezel that meets NEMA 4/IP65 requirements for indoor use when properly installed. Installation Category II, Pollution Degree 2. Case body is black, high impact plastic (panel gasket and mounting clips included).

22. **CONNECTION:** Removable terminal blocks

23. **WEIGHT:** 1.2 lbs (0.5 kg)

## ISOLATED RE-TRANSMITTED ANALOG OUTPUT OPTION

### 4 to 20 mA

The re-transmitted analog output option transmits a digitally programmable 4 to 20 mA current to drive chart recorders, remote indicators and controllers. The compliance is 10 VDC. Non-standard current ranges within the 4 to 20 mA range can be supported by calculating the slope and intercept of the display/output and calculating the required display values at 4 and 20 mA.

### 0 to 10 VDC

The re-transmitted analog output option transmits a digitally programmable 0 to 10 VDC output signal to drive chart recorders, remote indicators and controllers. Non-standard current ranges within the 0 to 10 VDC range can be supported by calculating the slope and intercept of the display/output and calculating the required display values to 0 and 10 VDC.

## TOTALIZER/PEAK/VALLEY/TEMPERATURE OFFSET AND SLOPE OPTION

The major feature of this option is its integrator/totalizer (accumulator) . The integrator simply totals (adds) input readings with a programmable time base and scaling coefficient. The integrator/totalizer may be reset via a remote input, by the front panel or through the serial communications loop. Alarms may be programmed to trigger from totalizer values or input values. A programmable low temperature level disable feature completes the integrator/totalizer features. At loss of power to the indicator, the contents of the totalizer are saved.

Other features of this option are peak and valley detection. The indicator will record the lowest reading (valley) and the highest reading (peak) , automatically, for later recall. This information is valuable when monitoring the limits of the process over any length of time which can span shifts, days, etc. (these values are stored at power-down) . A remote input can be programmed to reset or engage the unit into a peak reading indicator. Additionally, the peak and valley can be viewed and reset from the front panel, if so programmed, and viewed and reset through the serial communication option.

The programmable temperature offset feature allows the operator to shift the displayed temperature reading. The operator may utilize this feature, for example, if switching probes, to compensate for differences in thermistor probe accuracy from one manufacturer to another. The displayed temperature reading can be offset either positive or negative to the actual measured temperature. Programming a positive number for the offset value increases the display value. Programming a negative number for the offset value decreases the display value. For example, programming +10 for the offset value will increase the displayed value by 10 throughout the entire range, or programming -10 for the offset value will decrease the display value by 10 throughout the entire range.

## ISOLATED ALARM OPTION

The alarm option consists of an additional printed circuit board with nine connections. Six of these terminals are for the two Form-C relays and the other three are for two open collector transistors, which act in parallel with the relays. The two alarms are completely independent with programmable values, hysteresis (*deadband*), high or low acting, auto or manual reset, triggering from input or total and they can be made to track each other, if desirable. If the alarms are programmed to latch (*manual reset*), then they can be reset either by the front panel or a remote input. The alarms can be made to trigger from either the integrator/totalizer or the input display, to actuate external alarms, control valves, etc.

Alarm #1 can be programmed to track Alarm #2 by enabling alarm tracking. This is useful in alarm set-ups where a pre-warning control activates before a second alarm shuts off the process when tracking is programmed. Changing the shut-off trip value (*alarm #2*) automatically changes the pre-warning value (*alarm #1*) an equal amount. Alarm and hysteresis values can be modified through the optional serial communications to provide automatic control.

## ISOLATED SERIAL COMMUNICATIONS OPTION

The serial communication option is a half-duplex, two-way 20 mA loop that can connect to a variety of printers, computers, terminals and controllers to suit many data-polling or automatic operation applications. The indicator responds to a host of commands, including change alarm value, reset totalizer and transmit temp (*input*) signal. Two loops are required for all hook-ups; a transmit (*out-going data*) loop and a receive (*in-coming data*) loop. Since the indicator monitors the receive loop for a busy signal (*current interrupted*) while transmitting, the receive loop must be connected even if the indicator is transmitting only, such as to a printer. A built-in 20 mA source is provided in the transmit loop. Additionally, multiple units and other Red Lion Controls instruments can be serially addressed, with a maximum address capability of 99 units. (*Note: There are serial hardware limitations which restrict this to a lower number of units per serial loop.*)

### PROGRAMMABLE FUNCTIONS

Programming of the indicator is divided into modular steps. Each module is a short sequence of data entries. The front panel buttons "UP" and "DOWN" (shown as "arrows" on the front panel) are used to change the data and set-ups, while the "P" button is used to *save* or *enter* the data. After pressing "P", which gains entry into the programming mode, the programming modules are identified by the message "Pro" and a number in the display. "UP" and "DOWN" are used to select the desired programming module and "P" is used to enter it. All of the subsequent programming steps follow the same procedure. The rear terminal labeled "PGM. DIS." must be ungrounded to gain access to programming. The following table lists the programming steps.

#### "Pro 0" - RETURN TO MEASUREMENT MODE

#### "Pro 1" - PROGRAM THERMISTOR TYPE, TEMPERATURE SCALE AND DECIMAL POINT POSITION

- "TYPE" - Select Thermistor type (400/700)
- "SCALE" - Enter either degree (F or C)
- "dECPNt" - Enter resolution (0 or 0.0)

#### "Pro 2" - PROGRAM TEMPERATURE SLOPE AND OFFSET

- "SLOPE" - Enter display slope (0.0001 to 9.9999)
- "OFFSET" - Enter offset (-999 to 9999)

#### "Pro 3" - PROGRAM FUNCTIONS ACCESSIBLE WITH FRONT PANEL LOCKOUT ENGAGED

- "dSP AL" - Enable display alarms
- "ENt AL" - Enable enter alarms †
- "dSPHYS" - Enable display hysteresis
- "ENtHYS" - Enable enter hysteresis †
- "rSt AL" - Enable reset latched alarms
- "dSPbUF" - Enable display of peak/valley readings
- "rStbUF" - Enable reset of peak/valley readings †
- "SELDSP" - Enable switching display between input and total
- "rSttOt" - Enable reset total
- "dSPOFF" - Enable display offset value
- "ENtOFF" - Enable enter offset value †

#### "Pro 4" - PROGRAM DIGITAL FILTERING AND REMOTE INPUT FUNCTION

- "FILtEr" - Enter level of digital filtering
  - 0 - No digital filtering
  - 1 - Normal filtering
  - 2 - Increased filtering
  - 3 - Maximum filtering
- "E1-CON" - Enter function of remote input
  - 0 - Offset temperature reading to zero
  - 1 - Reset totalizer
  - 2 - Reset and gate totalizer
  - 3 - Gate totalizer
  - 4 - Display hold
  - 5 - Reset peak/valley
  - 6 - Reset peak and start peak indicator
  - 7 - Reset valley and start valley indicator
  - 8 - Reset latched alarms
  - 9 - Reset all alarms
  - 10 - Toggle display between input and totalizer
  - 11 - Offset input to zero and totalize the offset values
  - 12 - Display hold with offset
  - 13 - Instrument reading synchronization
  - 14 - Print request
- "E2-CON" - Same functions as E1-CON

#### "Pro 5" - PROGRAM TOTALIZER

- "dECPNt" - Enter decimal point for totalizer
- "tbASE" - Enter time base
  - 0 - second
  - 1 - minute
  - 2 - hour
- "SCLFAC" - Enter multiplying scale factor
- "Lo-cut" - Enter low-signal cut out

#### "Pro 6" - PROGRAM ALARMS

- "trAc" - Enable alarm value tracking
- "dISP" - Enable display alarm annunciators
- "LAtC-1" - Enable alarm #1 latching
- "ASN-1" - Enter alarm #1 trigger source (input or total)
- "AL-1" - Enter alarm #1 value
- "HYS-1" - Enter hysteresis value for alarm #1
- "Act-1" - Enter alarm #1 action (high or low)
- "LAtC-2" - Enable alarm #2 latching
- "ASN-2" - Enter alarm #2 trigger source (input or total)
- "AL-2" - Enter alarm #2 value
- "HYS-2" - Enter hysteresis value for alarm #2
- "Act-2" - Enter alarm #2 action (high or low)

#### "Pro 7" - PROGRAM SERIAL COMMUNICATIONS

- "bAud" - Enter baud rate
- "AddrES" - Enter loop address number (0-99)
- "Print" - Enter print function, or "P" command function through Serial Option
  - 0 - temp.
  - 1 - temp., peak/valley and offset
  - 2 - temp. and alarms
  - 3 - temp., peak/valley, alarms, hysteresis, and offset
  - 4 - integrator/totalizer
  - 5 - temp. and integrator/totalizer
  - 6 - temp., integrator/totalizer, peak/valley, and offset
  - 7 - integrator/totalizer and alarms
  - 8 - temp., integrator/totalizer, and alarms
  - 9 - temp., integrator/totalizer, peak/valley, alarms, hysteresis, and offset
- "FULL" - Enable complete or abbreviated printing

#### "Pro 8" - PROGRAM RE-TRANSMITTED ANALOG OUTPUT

- "ASIN" - Select source of analog output (input or total)
- "AN-Lo" - Enter 4 mA or 0 VDC display value
- "AN-HI" - Enter 20 mA or 10 VDC display value

#### "Pro 9" - SERVICE OPERATIONS (Protected by access code)

† - This sequence may be subject to being locked-out due to other programmed sequences.

## TOTALIZER EXAMPLE STERILIZATION APPLICATION

A 400 Series 2,252 Ω thermistor is employed to monitor the temperature of a sterilization bath used to sterilize equipment in the production of drugs at a pharmaceutical company. The sterilization bath varies in temperature with the amount of equipment in the bath and therefore, longer soak intervals may be required to ensure complete sterilization. The optional totalizer of the IMY is used to integrate a time-temperature profile of the sterilization process and the setpoint/alarm option is used to alert operators when the totalizing temperature has exceeded the required value, signaling that sterilization is complete. The temperature of the bath can fluctuate from 150 to 200°F and the additional alarm is used to activate if the bath falls below 140°F.

In order to effect sterilization, the equipment must be in the bath for 1500 degree-minutes (150°F for 10 minutes, 200°F for 7.5 minutes, etc.) as long as the temperature remains above 140°F. The totalizer is programmed for a "1 minute" timebase to provide direct readout in degree-minutes. Alarm #1 is programmed to trigger from the integrator and is set to activate at a value of 1500. Alarm #2 is programmed to trigger directly from the temperature and is assigned to be lo-acting (when the temperature falls below 140°F) and is programmed to latch at 140°F. Remote input "E1-CON" (TBA #4) is programmed to reset the totalizer after each sterilization operation. The display can be switched between temperature and totalizer readout from the front panel by using the "up" and "down" buttons. The optional 4 to 20 mA retransmitted output is used to provide a temperature profile of the bath on a chart recorder. The output is digitally scaled to retransmit 4 mA at 100°F and 20 mA at 250°F. An external key switch is connected from TBA #3 (Program Disable) to ground. With this terminal grounded, unauthorized modification of the programmed data is prevented.

"Pro 1"... "tyPE"	400	Select 400 Series Thermistor
"SCALE"	F	Degrees Fahrenheit
"dECPNt"	0	1 degree resolution
"Pro 2"... "SLOPE"	1.0000	Slope = 1
"OFFSE"	0	No offset
"Pro 3"... "dSP AL"	yes	Check alarms
"Ent Al"	yes	Modify alarms
"dSPHyS"	no	
"rSt AL"	no	Reset latched alarms from front panel
"dSPbUF"	no	
"SELdSP"	yes	Allow display mode switching
"rStOt"	no	
"Pro 4"... "FILtEr"	0	Set digital filter to minimum
"E1-CON "	1	Reset totalizer from remote switch
"Pro 5"... "tBASE"	1	Set totalizer for "1-minute"
"SCLFAC"	1.000	
"Lo-cut"	140 F	
"Pro 6"... "trAC"	no	No alarm tracking
"dISp"	yes	Display annunciation of alarm status
"LAtC-1"	no	Alarm will reset when totalizer reset
"ASN-1"	totAL	Triggers from totalizer (Accumulator)
"AL-1"	1500 F	Triggers at 1500
"HyS-1"	1 F	Deadband range (not critical)
"Act-1"	HI	Triggers when above 1500 (Accum.)
"LAtC-2"	yes	Latch under temperature alarm
"ASN-2"	InPut	Trigger from temperature (Input)
"AL-2"	140 F	Trigger at 140°F
"Act-2"	Lo	Triggers when below 140°F
"Pro 8"... "ASIN"	InPut	Trigger from temperature (input)
"AN-LO"	100 F	Temperature at which 4 mA is retransmitted
"AN-HI"	250 F	Temperature at which 20 mA is retransmitted

## TEMPERATURE MONITORING EXAMPLE

An IMY is installed as a monitoring device and back-up controller for a freezer storage facility. Normally, the freezer temperature is maintained at about -29°C ±2°. The absolute maximum allowable temperature of the freezer is 0°C. In the event of a system failure, alarm output #1 of the IMY is programmed to start a secondary cooling system with a warning bell when the temperature rises above -17°C (indicating a possible failure of the main cooling system). This alarm is programmed to latch in order to assure that personnel inform maintenance of a possible problem. Key switches are installed to lock out the front panel from unauthorized personnel and to provide the means to reset the latched alarm. The Integrator/totalizer option is specified to store peak and valley temperatures overnight, weekly, etc. Programming module #5 (Pro 5) is used to set up the integrator. The re-transmitted analog output is specified to drive a chart recorder with 4 to 20 mA for a hard copy of temperature profiles for later evaluation.

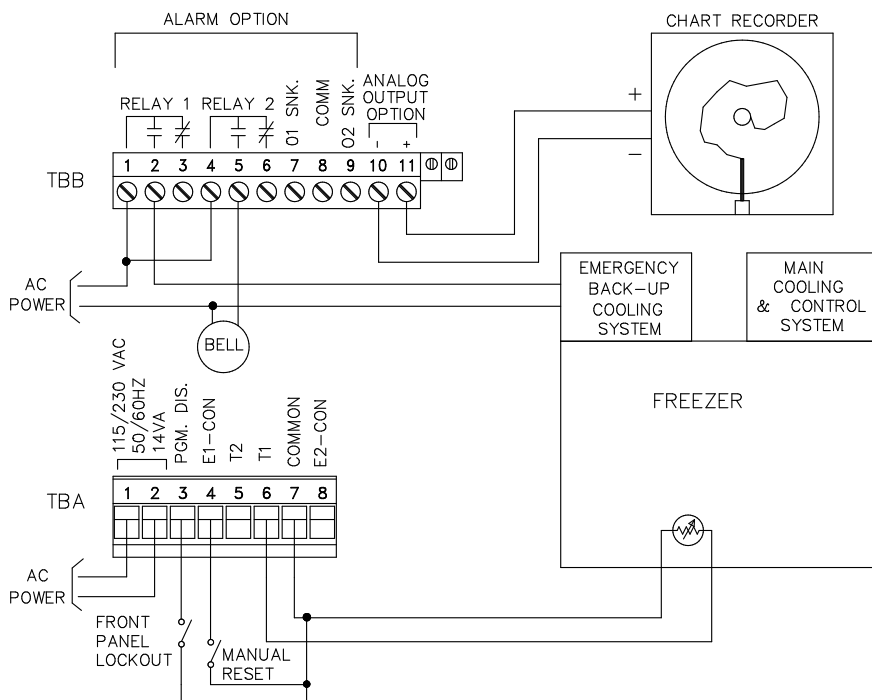

## ORDERING INFORMATION

MODEL NO	DESCRIPTION	TOTALIZER/ PEAK/VALLEY/ SLOPE/OFFSET/ E2-CON	DUAL ALARMS	SERIAL OUTPUT	ANALOG OUTPUT	PART NUMBERS FOR AVAILABLE SUPPLY VOLTAGES	
						*10 to 30 VDC	115/230 VAC
IMY	Intelligent Meter for Thermistor Inputs	NO	NO	NO	NO	IMY00130	IMY00160
		NO	YES	NO	NO	IMY00132	IMY00162
		YES	NO	NO	NO	IMY02130	IMY02160
		YES	NO	YES	NO	IMY02131	IMY02161
		YES	YES	NO	NO	IMY02132	IMY02162
		YES	NO	NO	4 to 20 mA	IMY02133	IMY02163
		YES	YES	YES	4 to 20 mA	IMY02137	IMY02167
YES	YES	YES	0 to 10 VDC	IMY02139	IMY02169		

For more information on Pricing, Enclosures & Panel Mount Kits refer to the RLC Catalog or contact your local RLC distributor.

\*Note: The 10 to 30 VDC versions of the IMY have not been specified for EMC.