

## MODEL CUB4I - MINIATURE D.C. CURRENT METER & MODEL CUB4V - MINIATURE D.C. VOLTMETER



- LCD, POSITIVE REFLECTIVE OR NEGATIVE TRANSMISSIVE WITH RED BACKLIGHTING
- FOUR SELECTABLE D.C. RANGES  
 0 to 199.9 mV, 1.999 V, 19.99 V, 199.9 V (CUB4V)  
 0 to 199.9 μA, 1.999 mA, 19.99 mA, 199.9 mA (CUB4I)
- 0.6 INCH (15.2 mm) HIGH LCD DIGITS
- BUILT-IN SCALING PROVIDED
- AUTO ZEROING CIRCUIT
- SELECTABLE DECIMAL POINTS
- WIRE CONNECTIONS MADE VIA SCREW CLAMP TYPE TERMINALS
- FITS DIN STANDARD CUT-OUT 2.68" (68 mm) x 1.30" (33 mm)
- NEMA 4X/IP65 SEALED FRONT PANEL BEZEL
- 9 TO 28 VDC POWERED

### DESCRIPTION

The CUB4 Volt and Current Meters are designed and manufactured using the latest technology for a high quality, compact, affordable instrument for use in industrial environments. Each unit has a 3½-digit LCD display with 0.6 inch (15.2 mm) high digits and a DIP switch selectable decimal point. The displays are available in positive image reflective (black digits, reflective background) or negative image transmissive (illuminated digits, dark background) with red backlighting.

The units are constructed of a lightweight, high impact plastic case with a clear viewing window. The sealed front panel meets NEMA 4X/IP65 specifications for wash-down and/or dusty environments, when properly installed. A CUB4V or CUB4I unit can be mounted in the same panel cutout as the CUBVD and CUBID units.

The optional Micro Line/Sensor Power Supply (MLPS1000) is designed to attach to the rear of an installed CUB4V or CUB4I to provide the necessary power for the unit. The optional supply can be powered from a 85-250 VAC source.

### SAFETY SUMMARY

All safety related regulations, local codes as well as instructions that appear in this document or on equipment must be observed to ensure personal safety and to prevent damage to either the device or equipment connected to it.

Do not use these products to replace proper safety interlocking. No software-based device (or any other solid-state device) should ever be designed to be responsible for the maintenance of personnel safety or consequential equipment not equipped with safeguards. Red Lion disclaims any responsibility for damages, either direct or consequential, that result from the use of this equipment in a manner not consistent with these specifications.

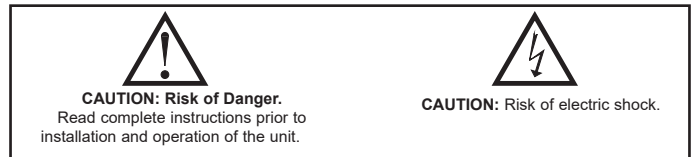

### ORDERING INFORMATION

MODEL NO.	DESCRIPTION	PART NUMBERS
CUB4V	DC Voltmeter	CUB4V000
	DC Voltmeter W/Red Backlighting	CUB4V020
CUB4I	DC Current Meter	CUB4I000
	DC Current Meter W/Red Backlighting	CUB4I020
MLPS	Micro Line/Sensor Power Supply	MLPS1000

### SPECIFICATIONS

1. **DISPLAY:** 3½-digit (-1999 to 1999), 0.6" (15.2 mm) high digits. Minus (-) sign is displayed when voltage or current is negative.
2. **DECIMAL POINTS:** DIP switch selectable decimal points allow the display to be read in tenths, hundredths or thousandths.
3. **POWER REQUIREMENTS:**  
**Reflective Versions:** 9 to 28 VDC at 4 mA max.  
**Backlight Versions:** 9 to 28 VDC @ 35 mA typ., 50 mA max. Above 26 VDC, derate operating temperature to 50°C.
4. **INPUT RANGES:**

D.C. VOLTAGE (DIP Switch Selectable)	D.C. CURRENT (JMPR. Selectable)
±199.9 mVDC	±199.9 μADC
±1.999 VDC	±1.999 mADC
±19.99 VDC	±19.99 mADC
±199.9 VDC	±199.9 mADC

### DIMENSIONS In inches [mm]

Note: Recommended minimum clearance (behind the panel) for mounting clip installation is 2.15" [54.6] H x 3.00" [76.2] W.

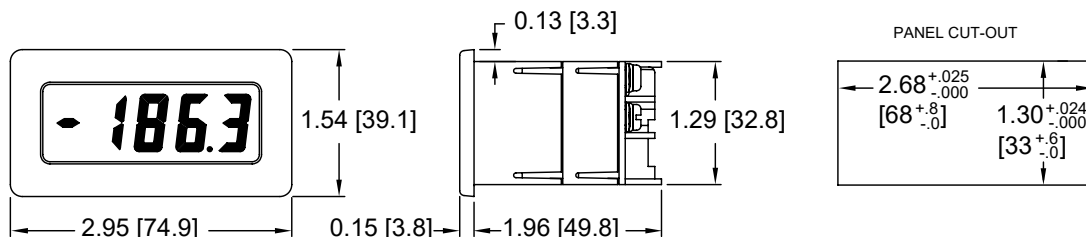

5. **ACCURACY:** (@ 23°C, less than 85% RH)

**D.C. Voltage:**  $\pm(0.1\% + 1 \text{ digit})$

**D.C. Current:**

**199.9  $\mu$ A, 1.999 mA, 19.99 mA ranges:**  $\pm(0.1\% + 1 \text{ digit})$

**199.9 mA range:**  $\pm(0.15\% + 1 \text{ digit})$

6. **OVERRANGE RATINGS, PROTECTION & INDICATION:**

9 to 28 VDC power circuit is not isolated from the signal circuit.

**Max Input Voltage:**

**0 to 199.9 mVDC Range:** 75 VDC

**All other voltage Ranges:** 300 VDC

**Max Input Current:**

**199.9  $\mu$ A through 19.99 mA:** 10 times max. range current

**199.9 mA:** 1 amp

**Overrange Indication:** Overrange is indicated by a "1" displayed in the most significant digit and the blanking of the three least significant digits.

7. **READING RATE:** 2.5 readings per second

8. **RESPONSE TIME:** 1.5 seconds to settle for a step change

9. **NORMAL MODE REJECTION:** 60 dB 50/60 Hz

10. **INPUT IMPEDANCE:**

**Voltmeter:** 1 M $\Omega$

**Current Meter:**

199.9  $\mu$ A - 1 K $\Omega$

19.99 mA - 10  $\Omega$

1.999 mA - 100  $\Omega$

199.9 mA - 1  $\Omega$

11. **CERTIFICATIONS AND COMPLIANCES:**

**CE Approved**

EN 61326-1 Immunity to Industrial Locations

Emission CISPR 11 Class B

IEC/EN 61010-1

RoHS Compliant

UL Recognized Component: File #E179259

Type 4X Enclosure rating (Face only)

IP65 Enclosure rating (Face only)

IP20 Enclosure rating (Rear of unit)

*Refer to EMC Installation Guidelines section of the bulletin for additional information.*

12. **ENVIRONMENTAL CONDITIONS:**

**Operating Temperature:** 0° to 60°C (above 50°C, derate backlight operating voltage to 26 VDC maximum).

**Storage Temperature:** -40° to 80°C

**Operating and Storage Humidity:** 85% max relative humidity (non-condensing) from 0 to 60°C.

**Vibration to IEC 68-2-6:** Operational 5-500 Hz, 5 g

**Shock to IEC 68-2-27:** Operational 30 g

**Temperature Coefficient:** 100 PPM/°C

**Altitude:** Up to 2000 meters.

13. **CONSTRUCTION:** High impact plastic case with clear viewing window. (Panel gasket and mounting clip included.) This unit is rated for NEMA 4X/IP65 indoor use. Installation Category II, Pollution Degree 2

14. **WEIGHT:** 3.3 oz. (93.5 g)

## INSTALLATION ENVIRONMENT

The unit should be installed in a location that does not exceed the maximum operating temperature and provides good air circulation. Placing the unit near devices that generate excessive heat should be avoided. The bezel should be cleaned only with a soft cloth and neutral soap product. Do NOT use solvents.

Continuous exposure to direct sunlight may accelerate the aging process of the bezel.

Do not use tools of any kind (screwdrivers, pens, pencils, etc.) to operate the keypad of the unit.

## Installation

The CUB4 Volt and Current meters meet NEMA 4X/IP65 requirements for indoor use, when properly installed. The units are intended to be mounted into an enclosed panel. A sponge rubber gasket, mounting clip, two screws, and nut fasteners are provided to install and seal the unit in the panel cutout.

The following procedure assures proper installation:

1. Cut panel opening to specified dimensions. Remove burrs and clean panel opening.
2. Carefully remove center section of the panel gasket and discard. Slide gasket over rear of the unit to the back of the bezel.
3. Slide nut fastener into slot on mounting clip and then insert mounting screw through nut on both sides of mounting clip. Tip of mounting screw should **NOT** project through hole on clip.
4. Install CUB4 unit through panel cutout.
5. Slide mounting clip over rear of unit until clip is against back of panel. The mounting clip and CUB4 housing have a latching feature to hold the unit in place until tightened.

**Note:** It is necessary to hold the unit in place when sliding mounting clip into position.

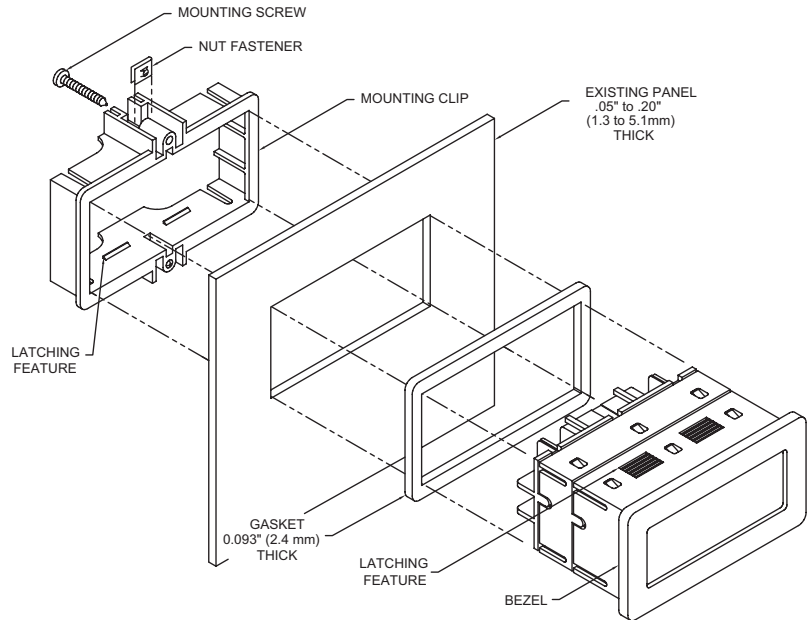

6. Alternately tighten each mounting screw to ensure uniform gasket pressure. Visually inspect the gasket for proper seal. The gasket should be compressed approximately 75 to 80% of its original thickness. (Recommended torque is 28 to 36 in.-oz.)
7. If the gasket is not adequately compressed and the mounting screws cannot be tightened any further, loosen mounting screws and insure that the clip is latched as close as possible to the panel.
8. Repeat step #6 for tightening the mounting screws.

## WIRING CONNECTIONS

The electrical connections are made via screw-clamp terminals located on the back of the unit. When wiring the unit, use the label to identify the wire position with the proper function. All conductors should meet voltage and current ratings for each terminal. Also cabling should conform to appropriate standards of good installation, local codes and regulations. It is recommended that power supplied to the unit be protected by a fuse or circuit breaker. Strip the wire, leaving approximately 1/4" bare wire exposed (stranded wires should be tinned with solder). Insert the wire into the screw-clamp terminal and tighten the screw until the wire is clamped tightly. Each terminal can accept up to two #14 AWG wires.

## DECIMAL POINT SELECTION

The CUB4 Volt and Current Meters can be set-up to read in 10ths, 100ths, or 1000ths. The decimal point position is DIP switch selectable for one of three locations. If all the DIP switches are set to the "OFF" position, then **NO** decimal point will appear in the display. The DIP switches are located at the rear of the unit.

## CUB4V SIGNAL INPUT

The voltage range is selected by setting one of the DIP switches S1 to S4 for the desired input voltage. The unit will indicate the direct readout for the range selected.

**Note:** Only one Voltage Range switch (S1-S4) should be selected (ON).

The SCALE DIP switch (S5) and the Scaling Potentiometer are used when it is necessary to scale the display to indicate other engineering units. The Scale switch should be left in the "OFF" position when the application requires direct voltage readout on the display.

The Calibration Potentiometer has been set at the factory and should not be adjusted unless the unit is being re-calibrated with an accurate voltage source.

The power supply common and signal common are connected internally at the same screw terminal marked COMM. The power supply common, and the signal common must be at the same voltage potential. The voltmeter cannot measure a voltage with a reference that is different than the power supply common.

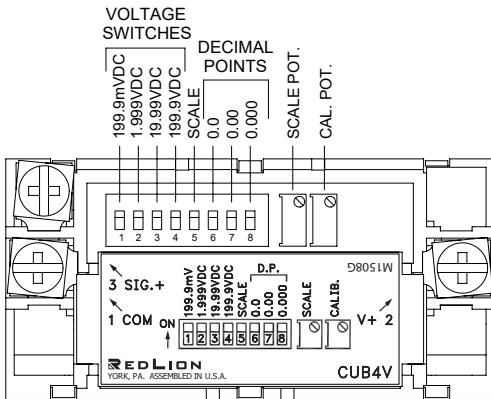

**CAUTION:** The Maximum Voltage for each switch position must not be exceeded or the unit may be damaged (See Specifications).



**CAUTION:** 9 to 28 VDC power circuit is not isolated from the signal circuit.

## VOLTMETER SCALING

In many industrial applications, a voltmeter is required to display a reading in terms of PSI, RPM, or some other unit of measure. The signal voltage being measured is normally generated by a transducer which senses the variable and delivers a linear output voltage. To provide the desired readout at the specified voltage, the voltmeter must be scaled. The Scale switch, when in the "ON" position, enables the Scale Potentiometer. The Scale Potentiometer is used with a voltage range to provide a method of scaling the unit. The voltage DIP switches are used to select one of the four coarse Division Factor ranges and the Scale Potentiometer is a fine scale adjustment within the selected range. The chart below shows the division factor range associated with each range selection switch.

### DIVISION FACTOR RANGE SELECTION CHART

- S1: 0-199.9 mVDC (0.1 D.F. 1.2)
- S2: 0-1.999 VDC (1.2 D.F. 10.5)
- S3: 0-19.99 VDC (10.5 D.F. 100.5)
- S4: 0-199.9 VDC (100.5 D.F. 1300)

**Note:** Enabling the Scale Potentiometer does NOT affect the calibration of the unit.

To determine the proper voltage range for an application requiring scaling, the "Division Factor" required to provide the proper display reading must first be determined by using the following formula.

### USING THE FORMULA:

$$D.F. = \frac{VT \times D.D.P.}{D.R.}$$

### WHERE:

- VT = Maximum Transducer Output
- D.D.P. = Display Decimal Point
- D.F. = Division Factor
- D.R. = Desired Reading

- D.D.P.
  - 0.000 = 1
  - 00.00 = 10
  - 000.0 = 100
  - 0000 = 1000
- The DISPLAY DECIMAL POINT (D.D.P.) is determined by the desired decimal point placement in the readout.

After the Division Factor for the application has been calculated, the proper voltage range switch that will provide for the Division Factor is set to the "ON" position. Use the "Division Factor Range Selection Chart" to choose the proper DIP switch setting.

**Note:** Only one voltage DIP switch should be turned on. Set the switch before the voltage signal is applied.

**EXAMPLE:** A relative humidity transducer delivers a 7.0 VDC voltage at a relative humidity of 75%.

$$D.F. = \frac{VT \times D.D.P.}{D.R.} = \frac{7.0 \times 1000}{75} = 93.3$$

This Division Factor is between 10.5 and 100.5, therefore DIP switch position S3 is set to the "ON" position. The Scaling Potentiometer is then adjusted for the desired readout at a known relative humidity.

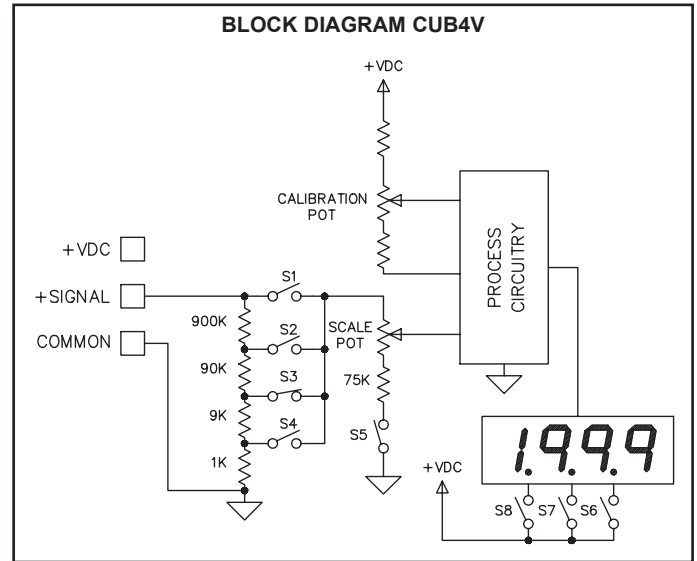

## CUB4I SIGNAL INPUT

The CUB4 Current Meter has four current ranges that are selected by positioning the jumper in the proper location on the male header strip.

The SCALE DIP switch (S1) and the Scaling Potentiometer are used when it is necessary to scale the display to indicate other engineering units. The Scale switch should be left in the "OFF" position when the application requires direct current readout on the display.

When the power supply is floating (unreferenced) to the desired measurement points, the (-) signal input and the power supply common should be connected. If the power supply is not floating (referenced), the common mode voltage between the (-) signal input and power supply common terminal must not be greater than 1.0 V peak. A common mode voltage higher than 1.0 V peak will result in a measurement error.

The Calibration Potentiometer has been set at the factory and should not be adjusted unless the unit is being re-calibrated with an accurate current source.

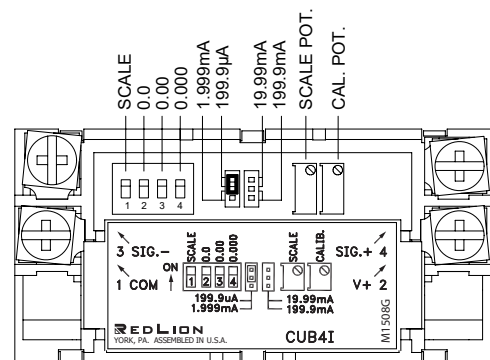

**CAUTION:** The Maximum Current for each jumper position must not be exceeded or the unit may be damaged (See Specifications).

## CURRENT METER SCALING

The CUB4 Current Meter display can be scaled to almost any lower numerical value. Setting the Scale switch to the “ON” position enables the Scale Potentiometer, which is used with the current range selection jumper to scale the unit. The Scale potentiometer can be set to divide the normal current reading by a division factor between 1 and 13.

**EXAMPLE:** The CUB4 Current Meter has been connected to measure a circuit current to 120.0 mA maximum. However, in this application, the display is to indicate percent of load current with 120.0 mA equivalent to 100.0 percent. The scale potentiometer is adjusted to reduce the normal 120.0 mA signal input display reading of 120.0 to indicate the desired reading of 100.0 on the display.

Scaling to obtain a numerical readout higher than the normal value of the current can also be accomplished in most cases by selecting a lower current range. However, the maximum current for the range must not be exceeded. (See Specifications for maximum input currents.)

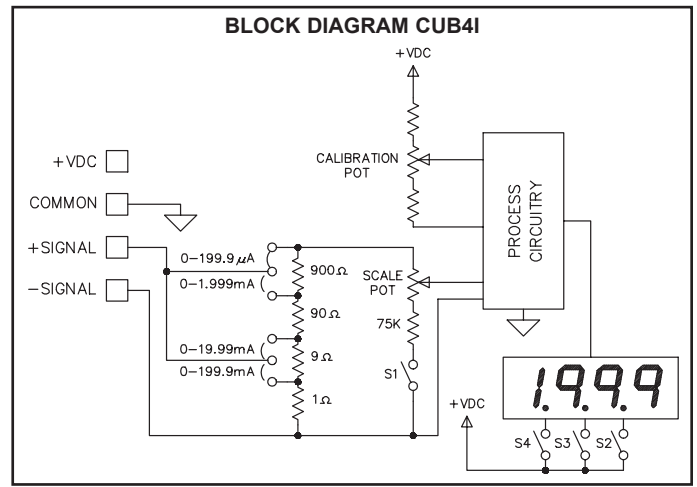

## TYPICAL VOLT & CURRENT MEASUREMENT APPLICATIONS

### Voltmeter Application

#### Indicating the Speed of a D.C. Motor

A foreman in a plant wants to get a more accurate indication of the speed at which a variable speed DC motor drive is operating. The only indication he has now is the position of a dial on the control panel.

The motor has a tachometer generator that will output a 10 VDC signal when the motor is running at its maximum speed of 1800 RPM. The power supply of the control has a 15 VDC output that can supply power to the CUB4V.

Since this application requires a non-standard readout, it will be necessary to scale the display. The Scale DIP switch is set to the “ON” position to enable the Scale Potentiometer. The Division Factor is calculated using the formula:

$$D.F. = \frac{\text{(Maximum output)} \times D.D.P.}{\text{(Desired Display)}}$$

$$D.F. = \frac{10 \times 1000}{1800}$$

$$D.F. = 5.5$$

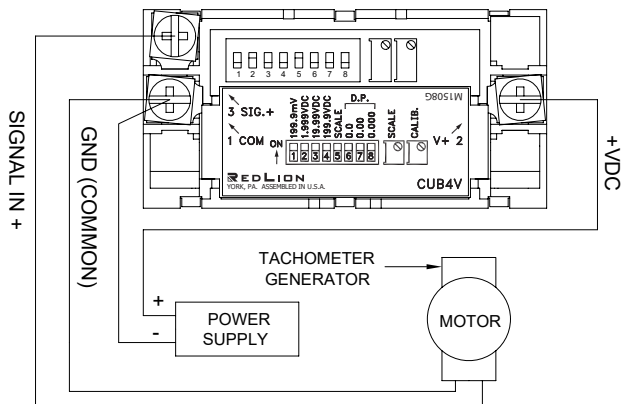

Since the division factor falls between 1.2 and 10.5, DIP switch position S2 is set to the “ON” position, according to the Division Factor Selection Chart.

To scale the CUB4 Voltmeter, the motor is run at full speed and a calibrated photo tachometer is used to obtain the exact speed. The Scale Potentiometer on the CUB4 Voltmeter is then adjusted until the display reading agrees with the tachometer. Alternately, the output of a precision voltage source set to +10 VDC can be connected to the signal input of the unit and then adjust the scaling potentiometer for the desired reading.

### Current Meter Application

#### Analog Meter Replacement

A manufacturer wants to replace several 1 mA DC analog meter movements with easy to read CUB4 Current Meters with backlighting. One application involves measuring the flow rate of a liquid to indicate 0 to 250 gallons per minute.

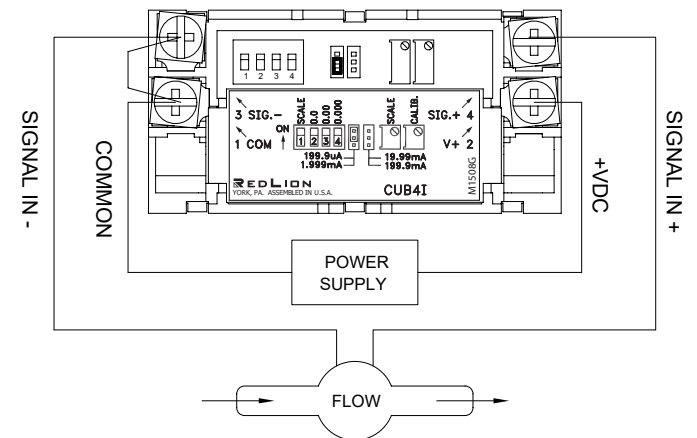

Since 1 mA of current flow requires a display reading of 250, the CUB4 Current Meter will need to be scaled. The Scale DIP switch is set to the “ON” position enabling the Scale Potentiometer. The proper current range for the application is then selected. The Scale potentiometer will divide the display reading by 1 to 13, for the particular current range selected. A reading of 250 is 4 times less than the normal reading at 1 mA for the 0 to 1.999 mA range, therefore the jumper is installed in the 0-1.999 mA range position. No decimal point is selected because the resolution is 1 gallon.

The CUB4 Current Meter can now be scaled. Apply 1 mA to the signal input and adjust the scale potentiometer to the desired reading.

## RED LION CONTROLS TECHNICAL SUPPORT

If for any reason you have trouble operating, connecting, or simply have questions concerning your new product, contact Red Lion’s technical support.

Support: [support.redlion.net](http://support.redlion.net)

Website: [www.redlion.net](http://www.redlion.net)

Inside US: +1 (877) 432-9908

Outside US: +1 (717) 767-6511

Corporate Headquarters

Red Lion Controls, Inc.

1750 5<sup>th</sup> Avenue York, PA 17403

## COPYRIGHT

© 2024 Red Lion Controls, Inc. All Rights Reserved. The terms Red Lion and the Red Lion logo are registered trademarks of Red Lion Controls. All other marks are the property of their respective owners.