

USER MANUAL

PAX2S – 1/8 DIN STRAIN GAGE PANEL METER



SAFETY SUMMARY

All safety related regulations, local codes as well as instructions that appear in this document or on equipment must be observed to ensure personal safety and to prevent damage to either the device or equipment connected to it.

Do not use these products to replace proper safety interlocking. No software-based device (or any other solid-state device) should ever be designed to be responsible for the maintenance of personnel safety or consequential equipment not equipped with safeguards. Red Lion disclaims any responsibility for damages, either direct or consequential, that result from the use of this equipment in a manner not consistent with these specifications.

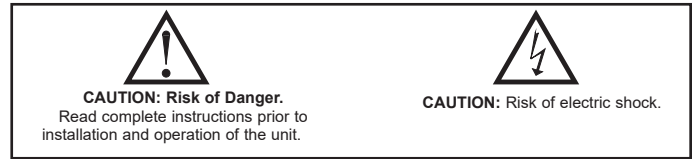

TABLE OF CONTENTS

Ordering Information	4
Using This Manual	5
Crimson Programming Software	5
General Meter Specifications	6
Option Cards	7
1.0 Installing the Meter	8
2.0 Setting the Jumpers	8
3.0 Installing Option Cards	9
4.0 Wiring the Meter	9
5.0 Front Panel Keys And Display Overview	11
Line 2 Display Loops	11
6.0 Programming The PAX2S	12
6.1 Input Parameters (I NPUT)	13
6.2 Output Parameters (O UTPUT)	17
6.3 Display Parameters (di SPly)	20
6.4 Communications Port Parameters (Port)	25
Serial Communications Overview	26
PAX2S Frequently Used Modbus Registers	27
6.5 Factory Service Operations (FACTrY)	31
Troubleshooting	32
PAX2S Programming Quick Overview	36

ORDERING INFORMATION

Meter Part Numbers

MODEL NO.	DESCRIPTION	PART NUMBER
PAX2S	Strain Gage Input Panel Meter	PAX2S000

Option Card and Accessories Part Numbers

TYPE	MODEL NO.	DESCRIPTION	PART NUMBER
Option Cards	PAXCDS	Dual Setpoint Relay Output Card	PAXCDS10
		Quad Setpoint Relay Output Card	PAXCDS20
		Quad Setpoint Sinking Open Collector Output Card	PAXCDS30
		Quad Setpoint Sourcing Open Collector Output Card	PAXCDS40
		Dual Triac/Dual SSR Drive Digital Output Card	PAXCDS50
		Quad Form C Relay Digital Output Card	PAXCDS60 *
	PAXCDC ¹	RS485 Serial Communications Card with Terminal Block	PAXCDC10
		Extended RS485 Serial Communications Card with Dual RJ11 Connector	PAXCDC1C
		RS232 Serial Communications Card with Terminal Block	PAXCDC20
		Extended RS232 Serial Communications Card with 9 Pin D Connector	PAXCDC2C
		DeviceNet Communications Card	PAXCDC30
		Profibus-DP Communications Card	PAXCDC50
	PAXCDL	Analog Output Card	PAXCDL10
Accessories	CBLUSB	USB Programming Cable Type A-Mini B	CBLUSB01
	RCP	Replacement Case with knock-out features.	RCPX2H00

Notes:

¹. For Modbus communications use RS485 Communications Output Card and configure communication (TYPE) parameter for Modbus.

* This card is not suitable for use in older PAX2 models. For proper installation, 3 case knock-out features must be present on the top case surface. To update a case to include these knock-outs, a replacement case is available.

USING THIS MANUAL

This manual contains installation and programming instructions for the PAX2S and all applicable option cards. To make installing the option card easier, it is recommended to use the Installation Guide provided with the card.

Only the portions of this manual that apply to the application need to be read. Minimally, we recommend that General Specifications, Reviewing the Front Buttons and Display, and Crimson® Programming Software portions of this manual be read in their entirety.

We recommend that unit programming be performed using Crimson programming software. When using Crimson, the programming portion of this manual serves as an overview of the programming options that are available through Crimson. The programming section of the manual will serve to provide expanded explanations of some of the PAX2S programming features found in Crimson. For users who do not intend to use Crimson to program their unit, this

manual includes information to provide for a user to program one, or all, of the programming parameters using the unit's keypad.

To find information regarding a specific topic or mnemonic, it is recommended that the manual be viewed on a computer and the "find" function be used. The alternate method of finding information is to identify the programming parameter involved and review the information contained in the section of the manual that pertains to that parameter.

CRIMSON PROGRAMMING SOFTWARE

Crimson® software is a Windows® based program that allows configuration of the PAX® from a PC. Crimson offers standard drop-down menu commands, that make it easy to program the PAX2. The unit's program can then be saved in a PC file for future use.

PROGRAMMING USING CRIMSON:

Crimson is included on the Flash Drive that is shipped with the PAX2. Check for updates to Crimson at <http://www.redlion.net/crimson2>.

- Install Crimson. Follow the installation instructions provided by the source from which Crimson is being downloaded or installed.
- Using a USB Type A-Mini B cable, plug the Mini B end of the cable into the PAX2 USB Programming Port.
- Plug the other end of the USB cable into an available USB port on the PC.
- Apply power to the PAX2. See Troubleshooting, on page 32, for error message resolution.
- Start Crimson.
- Click the Crimson "Link" tab.
- Click "Extract..."
 - o Crimson will extract the current program settings from the PAX2.
 - o If the PAX2 has not been programmed, the extracted file will contain factory settings. Note that the PAX2 factory settings vary based on the option cards installed.
- A programming selection screen will appear. Double click on an applicable programming selection and make program specific parameter selections. When completed, click "Close" and continue selecting applicable programming selections and making appropriate parameter selections. Continue until all necessary programming parameters have been configured.
- When all programming selections have been made, save the configuration file.
- Download the configuration file to the PAX2 by clicking the "Link" tab and selecting "Update".

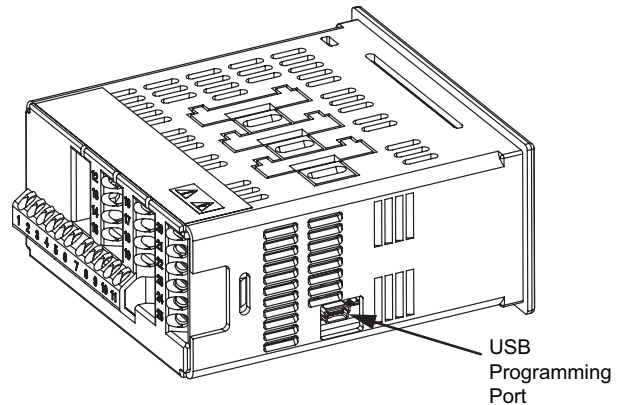

GENERAL METER SPECIFICATIONS

1. **DISPLAY:** Positive image LCD
 Top Line - 6 digit, 0.71" (18 mm), with tri-color backlight (red, green or orange), display range: -199,999 to 999,999;
 Bottom Line - 9 digit, 0.35" (8.9 mm), with green backlight, display range: -199,999,999 to 999,999,999

2. **POWER:**
 AC Power: 40 to 250 VAC, 50/60 Hz, 20 VA
 DC Power: 21.6 to 250 VDC, 8 W
 Isolation: 2300 Vrms for 1 min. to all inputs and outputs.

3. **ANNUNCIATORS:** Backlight color: Red
 1 - setpoint alarm 1 3 - setpoint alarm 3
 2 - setpoint alarm 2 4 - setpoint alarm 4
 Line 1 Units Label – programmable 3 digit units annunciator with tri-color backlight (red, green or orange)

4. **KEYPAD:** 2 programmable function keys, 4 keys total
 5. **A/D CONVERTER:** 24 bit resolution

6. **UPDATE RATES:**
 A/D conversion rate: programmable 5 to 160 readings/sec.
 Step response:

Input Rate	5	10	20	40	80	160	Readings/Sec
Response Time *	600	400	200	100	50	30	msec response time *

* - max. to within 99% of final readout value (digital filter disabled)

Display update rate: 1 to 20 updates/sec.
 Setpoint output on/off delay time: 0 to 3275 sec.
 Analog output update rate: 0 to 10 sec
 Max./Min. capture delay time: 0 to 3275 sec.

7. **DISPLAY MESSAGES:**
 "OLOL" - Appears when measurement exceeds + signal range.
 "ULUL" - Appears when measurement exceeds - signal range
 ". . . ." - Appears when display values exceed + display range.
 "-" - Appears when display values exceed - display range.

8. **INPUT:**
 Connection Type: 4-wire bridge (differential); 2-wire (single-ended)
 Common Mode Range (with respect to input common): 0 to +5 VDC
 Rejection: 80 dB (DC to 120 Hz)

INPUT RANGE	ACCURACY* (18 to 28°C)	ACCURACY* (0 to 50°C)	IMPEDANCE/ COMPLIANCE	MAX CONT. OVERLOAD	** RESOLUTION
± 24 mVDC	0.02% of rdg + 3 µV	0.07% of rdg + 4 µV	100 Mohm	30 V	1 µV
± 240 mVDC	0.02% of rdg + 30 µV	0.07% of rdg + 40 µV	100 Mohm	30 V	10 µV

* After 20 minute warm-up. Accuracy is specified in two ways: Accuracy over an 18 to 28°C and 10 to 75% RH environment; and accuracy over a 0 to 50°C and 0 to 85% RH (non-condensing environment). Accuracy over the 0 to 50°C range includes the temperature coefficient effect of the unit.

** Higher resolution can be achieved via input scaling

9. **EXCITATION POWER:** Jumper selectable
 +5 VDC @ 65 mADC max., +/-2%
 +10 VDC @ 125 mADC max., +/-2%
 Temperature Coefficient (ratio metric): 20 ppm/°C max.

10. **USER INPUTS:** Three programmable user inputs
 Max. Continuous Input: 30 VDC

Isolation To Sensor Input Common: Not isolated.
 Response Time: 12 msec. max.
 Logic State: User programmable (L/S/R/E) for sink/source (L/H) logic

INPUT STATE (L/S/R/E)	LO/SINK	HI/SOURCE
Active	20 KΩ pull-up to +3.3 V V _{IN} < 1.1 VDC	20 KΩ pull-down V _{IN} > 2.2 VDC
Inactive	V _{IN} > 2.2 VDC	V _{IN} < 1.1 VDC

11. **TOTALIZER:**
 Time Base: second, minute, hour, or day
 Batch: Can accumulate (gate) input display from a user input
 Time Accuracy: 0.01% typical
 Decimal Point: 0 to 0.0000
 Scale Factor: 0.001 to 65.000
 Low Signal Cut-out: -199,999 to 999,999
 Total: 6 digits on Line 1; 9 digits on Line 2

12. **CUSTOM LINEARIZATION:**
 Data Point Pairs: Selectable from 2 to 16
 Display Range: -199,999 to 999,999
 Decimal Point: 0 to 0.0000

13. **MEMORY:** Nonvolatile memory retains all programmable parameters and display values.

14. **ENVIRONMENTAL CONDITIONS:**
 Operating Temperature Range: 0 to 50 °C
 Storage Temperature Range: -40 to 60 °C
 Vibration to IEC 68-2-6: Operational 5-150 Hz, 2 g
 Shock to IEC 68-2-27: Operational 25 g (10 g relay)
 Operating and Storage Humidity: 0 to 85% max. RH non-condensing
 Altitude: Up to 2000 meters

15. **CERTIFICATIONS AND COMPLIANCES:**

CE Approved
 EN 61326-1 Immunity to Industrial Locations
 Emission CISPR 11 Class A
 IEC/EN 61010-1
 RoHS Compliant
 UL Listed: File #E179259
 Type 4X Indoor Enclosure rating (Face only)
 IP65 Enclosure rating (Face only)
 IP20 Enclosure rating (Rear of unit)
 Refer to EMC Installation Guidelines section of the bulletin for additional information.

16. **CONNECTIONS:** High compression cage-clamp terminal block
 Wire Strip Length: 0.3" (7.5 mm)
 Wire Gauge Capacity: 26 to 16 AWG (0.14 to 1.5 mm²)
 Torque: 4.4-5.3 inch-lbs (0.5-0.6 N-m)

17. **CONSTRUCTION:** This unit is rated Type 4X/IP65 for indoor use only.
 IP20 Touch safe. Installation Category II, Pollution Degree 2. One piece bezel/ case. Flame resistant. Synthetic rubber keypad. Panel gasket and mounting clip included.

18. **WEIGHT:** 8 oz. (226.8 g)

DIMENSIONS In inches [mm]

Note: Recommended minimum clearance (behind the panel) for mounting clip installation is 2.1" [53.4] H x 5.5" [140] W.

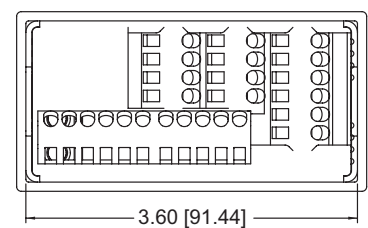
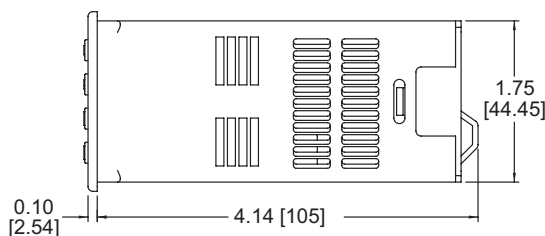
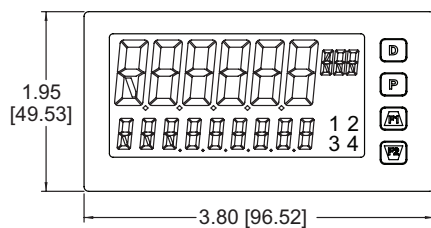

OPTION CARDS



WARNING: Disconnect all power to the unit before installing option cards.

Adding Option Cards

The PAX2 can be fitted with up to three option cards. The details for each option card can be reviewed in the specification section below. Only one card from each function type can be installed at a time. The function types include Setpoint Alarms (PAXCDS), Communications (PAXCDC), and Analog Output (PAXCDL). The option cards can be installed initially or at a later date.

COMMUNICATION CARDS (PAXCDC)

A variety of communication protocols are available for the PAX2. Only one PAXCDC card can be installed at a time. *Note: For Modbus communications use RS485 Communications Output Card and configure communication (TYPE) parameter for Modbus.*

SERIAL COMMUNICATIONS CARD: PAXCDC1_ and PAXCDC2_

Type: RS485 or RS232

Communication Type: Modbus ASCII, RLC Protocol (ASCII), and Modbus RTU

Isolation To Sensor & User Input Commons: 500 Vrms for 1 min.
Not Isolated from all other commons.

Data: 7/8 bits

Baud: 1200 to 38,400

Parity: no, odd or even

Bus Address: Selectable 0 to 99 (RLC Protocol), or 1 to 247 (Modbus Protocol), Max. 32 meters per line (RS485)

Transmit Delay: Selectable for 0 to 0.250 sec (+2 msec min)

DEVICENET™ CARD: PAXCDC30

Compatibility: Group 2 Server Only, not UCMM capable

Baud Rates: 125 Kbaud, 250 Kbaud, and 500 Kbaud

Bus Interface: Phillips 82C250 or equivalent with MIS wiring protection per DeviceNet™ Volume I Section 10.2.2.

Node Isolation: Bus powered, isolated node

Host Isolation: 500 Vrms for 1 minute between DeviceNet™ and unit input common.

PROFIBUS-DP CARD: PAXCDC50

Fieldbus Type: Profibus-DP as per EN 50170, implemented with Siemens SPC3 ASIC

Conformance: PNO Certified Profibus-DP Slave Device

Baud Rates: Automatic baud rate detection in the range 9.6 Kbaud to 12 Mbaud

Station Address: 0 to 125, set by rotary switches.

Connection: 9-pin Female D-Sub connector

Network Isolation: 500 Vrms for 1 minute between Profibus network and sensor and user input commons. Not isolated from all other commons.

SETPOINT CARDS (PAXCDS)

The PAX2 has 6 available setpoint alarm output option cards. Only one PAXCDS card can be installed at a time. (Logic state of the outputs can be reversed in the programming.) These option cards include:

DUAL RELAY CARD: PAXCDS10

Type: Two FORM-C relays

Isolation To Sensor & User Input Commons: 2000 Vrms for 1 min.

Contact Rating:

One Relay Energized: 5 amps @ 120/240 VAC or 28 VDC (resistive load).
Total current with both relays energized not to exceed 5 amps

Life Expectancy: 100 K cycles min. at full load rating. External RC snubber extends relay life for operation with inductive loads

QUAD RELAY CARD: PAXCDS20

Type: Four FORM-A relays

Isolation To Sensor & User Input Commons: 2300 Vrms for 1 min.

Contact Rating:

One Relay Energized: 3 amps @ 240 VAC or 30 VDC (resistive load).
Total current with all four relays energized not to exceed 4 amps

Life Expectancy: 100K cycles min. at full load rating. External RC snubber extends relay life for operation with inductive loads

QUAD SINKING OPEN COLLECTOR CARD: PAXCDS30

Type: Four isolated sinking NPN transistors.

Isolation To Sensor & User Input Commons: 500 Vrms for 1 min.
Not Isolated from all other commons.

Rating: 100 mA max @ $V_{SAT} = 0.7$ V max. $V_{MAX} = 30$ V

QUAD SOURCING OPEN COLLECTOR CARD: PAXCDS40

Type: Four isolated sourcing PNP transistors.

Isolation To Sensor & User Input Commons: 500 Vrms for 1 min.
Not Isolated from all other commons.

Rating: Internal supply: 18 VDC unregulated, 30 mA max. total
External supply: 30 VDC max., 100 mA max. each output

DUAL TRIAC/DUAL SSR DRIVE CARD: PAXCDS50

Triac:

Type: Isolated, zero crossing detection

Voltage: 260 VAC max., 20 VAC min.

Max Load Current: 1 Amp @ 25°C

0.75 Amp @ 50°C

Total load current with both triacs ON not to exceed 1.5 Amps

Min Load Current: 5 mA

Off State Leakage Current: 1 mA max @ 60 Hz

Operating Frequency: 20-400 Hz

SSR Drive:

Type: Two isolated sourcing PNP Transistors.

Isolation To Sensor & User Input Commons: 500 Vrms for 1 min.
Not Isolated from all other commons.

Rating:

Output Voltage: 18/24 VDC (unit dependent) $\pm 10\%$, 30 mA max.
total both outputs

QUAD FORM C RELAY CARD: PAXCDS60

Type: Four FORM-C relays

Isolation To Sensor & User Input Commons: 500 Vrms for 1 min.

Contact Rating:

Rated Load: 3 Amp @ 30 VDC/125 VAC

Total Current With All Four Relays Energized not to exceed 4 amps

Life Expectancy: 100 K cycles min. at full load rating. External RC snubber extends relay life for operation with inductive loads

ALL SETPOINT CARDS

Response Time: See Update Rates step response specification on page 6;
add 6 msec (typical) for relay card

LINEAR DC OUTPUT (PAXCDL)

Either a 0(4)-20 mA or 0-10 V retransmitted linear DC output is available from the analog output option card. The programmable output low and high scaling can be based on various display values. Reverse slope output is possible by reversing the scaling point positions.

ANALOG OUTPUT CARD: PAXCDL10

Types: 0 to 20 mA, 4 to 20 mA or 0 to 10 VDC

Isolation To Sensor & User Input Commons: 500 Vrms for 1 min.
Not Isolated from all other commons.

Accuracy: 0.17% of FS (18 to 28 °C); 0.4% of FS (0 to 50 °C)

Resolution: 1/3500

Compliance: 10 VDC: 10 K Ω load min., 20 mA; 500 Ω load max.

Powered: Self-powered

Update Response: See Update Rates specification on page 6.

1.0 INSTALLING THE METER

Installation

The PAX2 meets Type 4X/IP65 requirements when properly installed. The unit is intended to be mounted into an enclosed panel. Prepare the panel cutout to the dimensions shown. Remove the panel latch from the unit. Slide the panel gasket over the rear of the unit to the back of the bezel. The unit should be installed fully assembled. Insert the unit into the panel cutout.

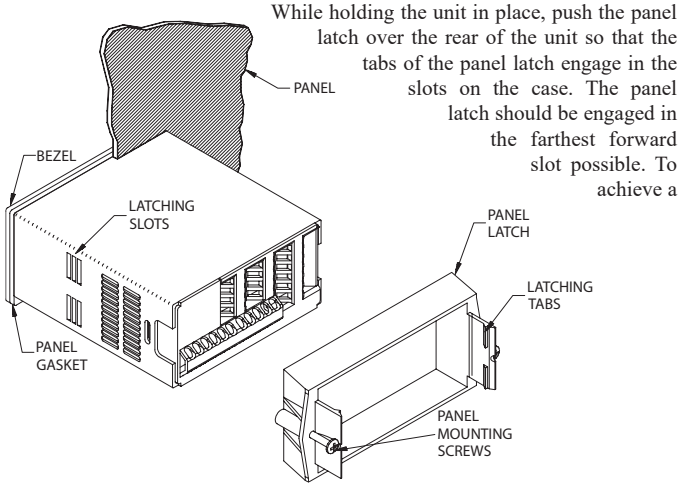

While holding the unit in place, push the panel latch over the rear of the unit so that the tabs of the panel latch engage in the slots on the case. The panel latch should be engaged in the farthest forward slot possible. To achieve a

proper seal, tighten the latch screws evenly until the unit is snug in the panel (Torque to approximately 7 in-lbs [79N-cm]). Do not over-tighten the screws.

Installation Environment

The unit should be installed in a location that does not exceed the operating temperature and provides good air circulation. Placing the unit near devices that generate excessive heat should be avoided.

The bezel should only be cleaned with a soft cloth and neutral soap product. Do NOT use solvents. Continuous exposure to direct sunlight may accelerate the aging process of the bezel.

Do not use tools of any kind (screwdrivers, pens, pencils, etc.) to operate the keypad of the unit.

PANEL CUT-OUT

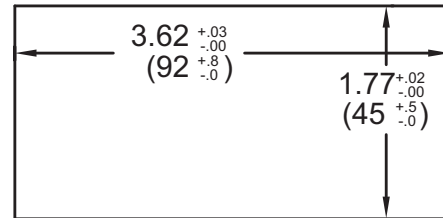

2.0 SETTING THE JUMPERS

Bridge Excitation

This jumper is used to select bridge excitation voltage level. Use the 5 V excitation with high output (3 mV/V) bridges, so that the higher sensitivity 24 mV range can be used. Using the 5 V excitation also reduces bridge power consumption compared to the 10 V excitation. A maximum of four 350 ohm load cells can be driven by the internal bridge excitation voltage.

JUMPER SELECTIONS

The indicates factory setting.

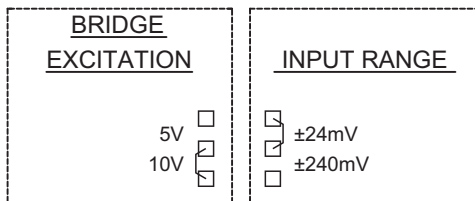

↓ REAR TERMINALS ↓

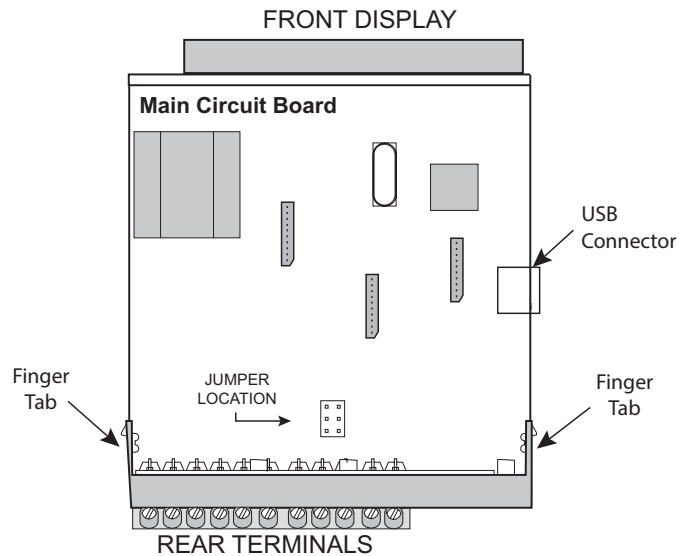

3.0 INSTALLING OPTION CARDS

The option cards are separately purchased cards that perform specific functions. These cards plug into the main circuit board of the unit. The option cards have many unique functions when used with the PAX2.



CAUTION: The option and main circuit boards contain static sensitive components. Before handling the cards, discharge static charges from your body by touching a grounded bare metal object. Ideally, handle the cards at a static controlled clean workstation. Dirt, oil or other contaminants that may contact the cards can adversely affect circuit operation.

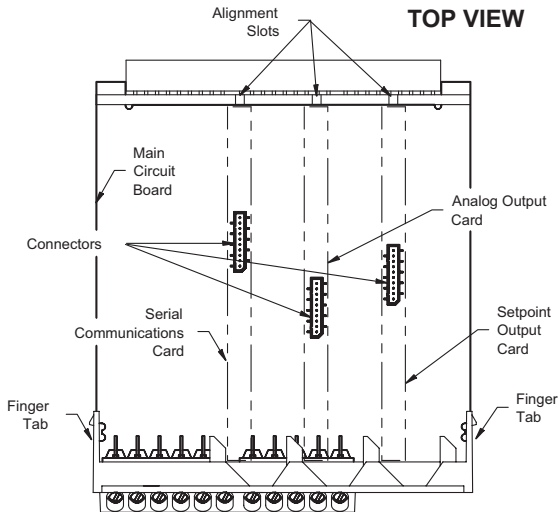

WARNING: Exposed line voltage exists on the circuit boards. Remove all power to the unit AND load circuits before removing the unit from its case.

To Install:

1. For option card specific installation instructions, see the installation instructions provided with the option card being installed.
2. When handling the main circuit board, hold it by the rear cover. When handling the option card, hold it by the terminal block.
3. Remove the main assembly from the rear of the case by squeezing both finger holds on the rear cover and pulling the assembly out of the case. Or use a small screwdriver to depress the side latches and pull the main assembly out of the case. Do not remove the rear cover from the main circuit board.
4. Locate the appropriate option card slot location on the main circuit board. Align the option card terminal block with the slot terminal block position on the rear cover. Align the option card connector with the main circuit board option card connector and then press to fully engage the connector. Verify the tab on the option card rests in the alignment slot on the display board.
5. If installing an option card that includes a terminal block on the top of the option card, a knock-out on the top of the PAX case will need to be removed to allow the top terminal block to be inserted later. Locate the  shaped knock-out that aligns with the option slot for which the option card is being installed. Carefully remove the knock-out, being careful not to remove additional knock-outs. Trim knock-out tabs (gates) that remain on the case. The top terminal block on the option card will need to be removed before completing step 6.
6. Slide the assembly back into the case. Be sure the rear cover latches engage in the case. If option card includes a top terminal block, install top terminal block at this time.

4.0 WIRING THE METER

WIRING OVERVIEW

Electrical connections are made via screw-clamp terminals located on the back of the unit. All conductors should conform to the meter's voltage and current ratings. All cabling should conform to appropriate standards of good installation, local codes and regulations. It is recommended that the power supplied to the unit (DC or AC) be protected by a fuse or circuit breaker.

When wiring the unit, compare the numbers embossed on the back of the unit case against those shown in wiring drawings for proper wire position. Strip the wire, according to the terminal block specifications (stranded wires should be tinned with solder). Insert the lead into the correct terminal and then tighten the terminal until the wire is secure (Pull wire to verify tightness).

EMC INSTALLATION GUIDELINES

Visit <http://www.redlion.net/emi> for more information on EMI guidelines, Safety and CE issues as they relate to Red Lion products.

4.1 POWER WIRING

AC Power

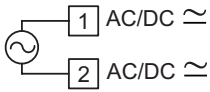

DC Power

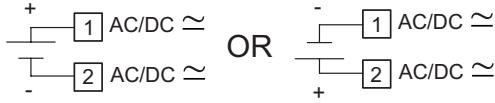

The power supplied to the unit shall employ a 15 Amp UL approved circuit breaker for AC input and a 1 Amp, 250 V UL approved fuse for DC input. It shall be easily accessible and marked as a disconnecting device to the installed unit. This device is not directly intended for connection to the mains without a reliable means to reduce transient over-voltages to 1500 V.

4.2 INPUT SIGNAL WIRING

Before connecting signal wires, the Input Range Jumper and Bridge Excitation Jumper should be verified for proper position.

2-Wire Single Ended Input

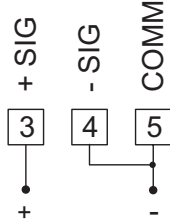

4-Wire Bridge Input

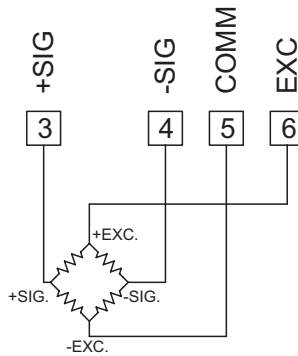

6-Wire Bridge Input

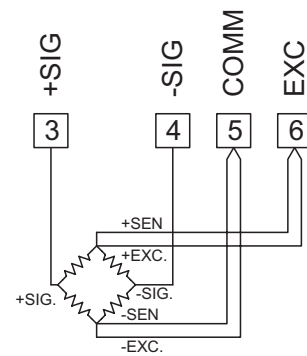

4.3 USER INPUT WIRING

If not using User Inputs, then skip this section. User Input terminal does not need to be wired in order to remain in inactive state.

Sinking Logic (*USERACT LO*)

When the *USERACT* parameter is programmed to *LO*, the user inputs are internally pulled up to +3.3 V with 20 K Ω resistance. The input is active when it is pulled low (<1.1 V).

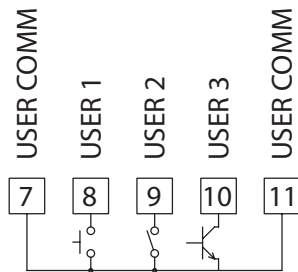

Sourcing Logic (*USERACT HI*)

When the *USERACT* parameter is programmed to *HI*, the user inputs are internally pulled down to 0 V with 20 K Ω resistance. The input is active when a voltage greater than 2.2 VDC is applied.

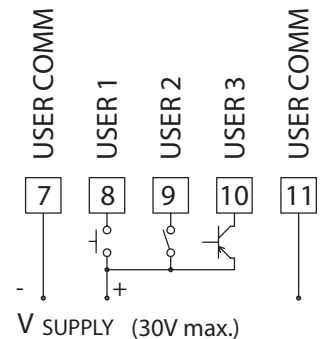

4.4 SETPOINT (ALARMS) WIRING

4.5 SERIAL COMMUNICATION WIRING

4.6 ANALOG OUTPUT WIRING

See appropriate option card bulletin for wiring details.

5.0 FRONT PANEL KEYS AND DISPLAY OVERVIEW

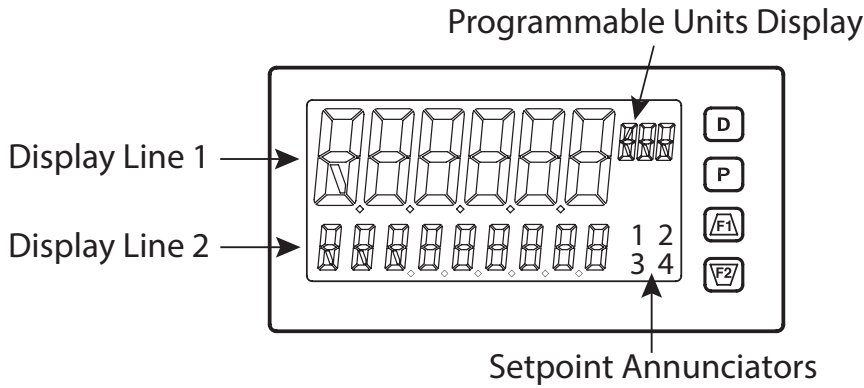

KEY DISPLAY MODE OPERATION

- D** Index Line 2 through enabled Line 2 display values
- P** Enter full programming mode or access the parameter and hidden display loops; Press and hold to skip parameters and go directly to Code or Programming Menu
- F1** User programmable Function key 1; hold for 3 seconds for user programmable second function 1*
- F2** User programmable Function key 2; hold for 3 seconds for user programmable second function 2*

*Factory setting for F1/F2 and second function F1/F2 is no mode

PROGRAMMING MODE OPERATION

- Return to the previous menu level (momentary press)
Quick exit to Display Mode (press and hold)
- Access the programming parameter menu, store selected parameter and index to next parameter
- Increment selected parameter value; Hold **F1** and momentarily press **F2** key to increment next decade or **D** key to increment by 1000's
- Decrement selected parameter value; Hold **F2** and momentarily press **F1** key to decrement next decade or **D** key to decrement by 1000's

DISPLAY LINE 1

Line 1 is the large, 6-digit top line display. Values such as, Input, Gross, Tare, Max(HI), Min(LO), Total and setpoints, can be shown on Line 1. The 3-digit Units mnemonic characters can be used to indicate which Line 1 display value is shown. Standard or custom mnemonics are available for the Line 1 values. See Line 1 parameters in the Display Parameters programming section for configuration details.

DISPLAY LINE 2

Line 2 is the smaller, 9-digit bottom line display. Values such as Input, Gross, Tare, Max(HI), Min(LO), Total, setpoints, and parameter List A/B status can all be shown on the Line 2 display. The display loops described below are used to view, reset and modify the selected display values, based on the Line 2 Value Access setting programmed for each available value. See Line 2 parameters in the Display Parameters programming section for configuration details.

LINE 2 DISPLAY LOOPS

The PAX2S offers three display loops to allow users quick access to needed information.

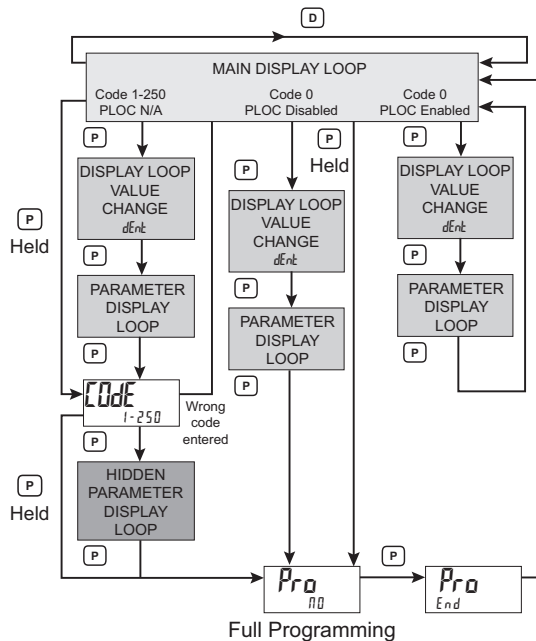

Main Display Loop

In the Main display loop, the D key is pressed to sequence through the selected Line 2 values. A left justified 2, 3 or 4-character mnemonic indicates which Line 2 value is currently shown. When in the Main display loop, the Function keys **F1** and **F2** perform the user functions programmed in the User Input parameter section.

Parameter and Hidden Parameter Display Loops

Display loops provide quick access to selected parameters that can be viewed and modified on Line 2 without having to enter Full Programming mode. These values include Parameter List A/B selection, setpoints, and display (color, intensity and contrast) settings. To utilize the Parameter or Hidden Parameter display loops, a security code (1-250) must be programmed. (See Programming Security Code in the Display Parameters programming section for details.)

The Parameter display loop is accessed by pressing the **P** key. The selected Parameter display loop values can be viewed and/or changed per the Line 2 Value Access setting programmed for each available value. The Hidden Parameter display loop follows the Parameter display loop, and can only be accessed when the correct security code is entered at the Code prompt. Combining the two parameter loops provides an area for parameters that require general access and/or protected or secure access depending on the application needs.

While in the Parameter and Hidden Parameter loops, pressing the **D** key will return the unit to the Main display loop. To directly access the Code prompt, press and hold the **P** key. This can be done from the Main display loop or at any point during the Parameter display loop. Also, to directly access Full Programming mode while in the Hidden Parameter loop, press and hold the **P** key to bypass any remaining Hidden Parameter loop values.

6.0 PROGRAMMING THE PAX2S

It is recommended that program settings be recorded as programming is performed. A blank Parameter Value Chart is provided at the end of this bulletin.

PROGRAMMING MODE ENTRY

The Programming Mode is entered by pressing the **P** key. Full Programming Mode will be accessible unless the unit is programmed to use the Parameter loop or Hidden Parameter display loop on the Line 2 display. In this case, programming access will be limited by a security code and/or a hardware program lock. (Refer to the previous section for details on Line 2 display loops and limited programming access.) Full Programming Mode permits all parameters to be viewed and modified. In this mode, the front panel keys change to Programming Mode Operations and certain user input functions are disabled.

MODULE ENTRY

The Programming Menu is organized into five modules. These modules group together parameters that are related in function. The **F1** and **F2** keys are used to select the desired module. The displayed module is entered by pressing the **P** key.

MODULE MENU

Upon entering a module, a parameter selection sub-menu is provided to choose the specific parameter type for programming. For example, this includes analog and user input under the Input Parameter menu. Use the **F1** and **F2** keys to select the desired parameter type, and press the **P** key to enter the parameter menu.

PARAMETER MENU

Upon entering the Parameter Menu, the **P** key is pressed to advance to a specific parameter to be changed. After completing the parameter menu, or upon pressing the **D** key, the display returns to the initial entry point for the parameter menu. For each additional press of the **D** key, the display returns to the previous level within the module until exiting the module entirely.

SELECTION/VALUE ENTRY

For each parameter, the top line display shows the parameter while the bottom line shows the selections/value for that parameter. The **F1** and **F2** keys are used to move through the selections/values for the parameter. Pressing the **P** key, stores and activates the displayed selection/value. This also advances the unit to the next parameter.

Numerical Value Entry

If the parameter is programmed for enter (Enter), the **F1** and **F2** keys are used to change the parameter values in any of the display loops.

The **F1** and **F2** keys will increment or decrement the parameter value. When the **F1** or **F2** key is pressed and held, the value automatically scrolls. The longer the key is held the faster the value scrolls.

For large value changes, press and hold the **F1** or **F2** key. While holding that key, momentarily press the opposite arrow key (**F2** or **F1**) to shift decades (10's 100's, etc), or momentarily press the **D** key and the value scrolls by 1000's as the arrow key is held. Releasing the arrow key removes the decade or 1000's scroll feature. The arrow keys can then be used to make small value changes as described above.

PROGRAMMING MODE EXIT

To exit the Programming Mode, press and hold the **D** key (from anywhere in the Programming Mode) or press the **P** key with *Pro AB* displayed. This will commit any stored parameter changes to memory and return the unit to the Display Mode. If a parameter was just changed, the **P** key must be pressed to store the change before pressing the **D** key. (If power loss occurs before returning to the Display Mode, verify recent parameter changes.)

PROGRAMMING TIPS

It is recommended to start with the Input Parameters and proceed through each module in sequence. If lost or confused while programming, press and hold the **D** key to exit programming mode and start over. It is recommended that program settings be recorded as programming is performed. When programming is complete lock out programming with a user input or lock-out code.

Factory Settings may be completely restored in the Factory Service Operations module. This is useful when encountering programming problems.

In Programming Menu:

* - Top line is green to indicate top level programming modules

** - Top line is orange to indicate module menu or sub-menu selection

*** - Top line is red to indicate a changeable parameter.

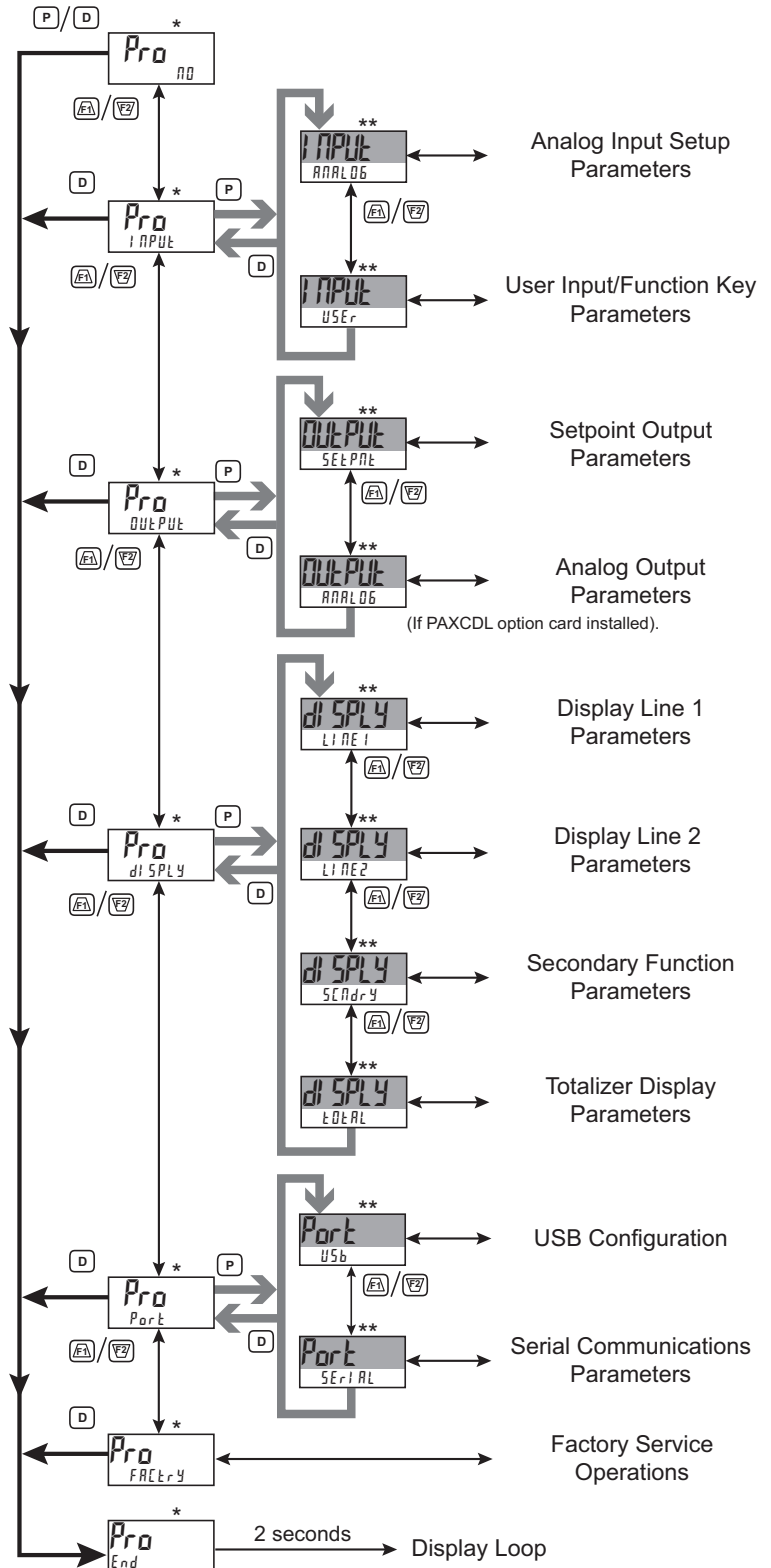

6.1 INPUT PARAMETERS (INPUT)

INPUT SELECT



ANALOG USER

Select the Input to be programmed.

6.1.1 ANALOG INPUT PARAMETERS (ANALOG)

This section details the programming for the analog input.

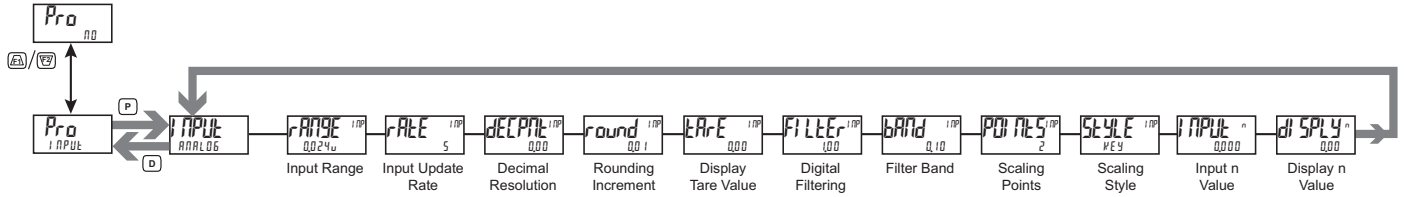

INPUT RANGE



0.024u 0.24u

Select the desired input range.

INPUT UPDATE RATE (/SEC)



5 10 20
40 80 160

Select the ADC conversion rate (conversions per second). The selection does not affect the display update rate, however it does affect setpoint and analog output response time. The default factory setting of 5 is recommended for most applications. Selecting a fast update rate may cause the display to appear very unstable.

DECIMAL RESOLUTION (Display Units)



0 0.00 0.0000
0.0 0.000

Select desired display resolution.

ROUNDING INCREMENT



1 2 5
10 20 50 100

Rounding selections other than one, cause the Input Display to 'round' to the nearest rounding increment selected (ie. rounding of '5' causes 122 to round to 120 and 123 to round to 125). Rounding starts at the least significant digit of the Input Display. Remaining parameter entries (scaling point values, setpoint values, etc.) are not automatically adjusted to this display rounding selection.

DISPLAY TARE (Offset) Value



- 19999 to 99999

The Display Tare(offset) Value is the difference between the Gross (absolute) Display value and the Relative (net) Display value for the same input level. The unit will automatically update this value after each Zero Display. The Display Tare Value can be directly keyed-in to intentionally add or remove display offset. See Relative/Gross Display and Zero Display explanations in the Input Parameters - User Input Module.

DIGITAL FILTERING



0.00 to 25.00 seconds

The input filter setting is a time constant expressed in hundredths of a second. The filter settles to 99% of the final display value within approximately 3 time constants. This is an Adaptive Digital Filter which is designed to steady the Input Display reading. A value of '0' disables filtering.

FILTER BAND



0 to 2500 display units

The digital filter will adapt to variations in the input signal. When the variation exceeds the input filter band value, the digital filter disengages. When the variation becomes less than the band value, the filter engages again. This allows for a stable readout, but permits the display to settle rapidly after a large process change. The value of the band is in display units. A band setting of '0' keeps the digital filter permanently engaged.

SCALING POINTS



2 to 16

Linear - Scaling Points (2)

For linear processes, only 2 scaling points are necessary. It is recommended that the 2 scaling points be at opposite ends of the input signal being applied. The points do not have to be the signal limits. Display scaling will be linear between and continue past the entered points up to the limits of the Input Signal Jumper position. Each scaling point has a coordinate-pair of Input Value (INPUT n) and an associated desired Display Value (DISPLAY n).

Nonlinear - Scaling Points (Greater than 2)

For non-linear processes, up to 16 scaling points may be used to provide a piece-wise linear approximation. (The greater the number of scaling points used, the greater the conformity accuracy.) The Input Display will be linear between scaling points that are sequential in program order. Each scaling point has a coordinate-pair of Input Value (INPUT n) and an associated desired Display Value (DISPLAY n). Data from tables or equations, or empirical data can be used to derive the required number of segments and data values for the coordinate pairs. Several linearization equations are available within Crimson software.

SCALING STYLE



KEY key-in data
APPLY apply signal

If Input Values and corresponding Display Values are known, the Key-in (KEY) scaling style can be used. This allows scaling without the presence of the input signal. If Input Values have to be derived from the actual input signal source or simulator, the Apply (APPLY) scaling style must be used.

INPUT VALUE FOR SCALING POINT 1



- 199999 to 999999

For Key-in (KEY), enter the known first Input Value by using the F1 or F2 arrow keys. (The Input Range selection sets up the decimal location for the Input Value). For Apply (APPLY), the existing programmed value will appear. If this is acceptable, press the P key to save and continue to the next parameter. To update this value, apply the input signal that corresponds to Scaling Point 1, press F2 key and the actual signal value will be displayed. Then press the P key to accept this value and continue to the next parameter.

DISPLAY VALUE FOR SCALING POINT 1



- 199999 to 999999

Enter the first coordinating Display Value by using the arrow keys. This is the same for KEY and APPLY scaling styles. The decimal point corresponds to the DECIMAL selection.

INPUT VALUE FOR SCALING POINT 2



- 199999 to 999999

For Key-in (KEY), enter the known second Input Value by using the F1 or F2 arrow keys. For Apply (APPLY), the existing programmed value will appear. If this is acceptable, press the P key to save and continue to the next parameter. To update this value, apply the input signal that corresponds to Scaling Point 2, press F2 key and the actual signal value will be displayed. Then press the P key to accept this value and continue to the next parameter. (Follow the same procedure if using more than 2 scaling points.)

DISPLAY VALUE FOR SCALING POINT 2



- 199999 to 999999

Enter the second coordinating Display Value by using the F1 or F2 arrow keys. This is the same for KEY and APPLY scaling styles. (Follow the same procedure if using more than 2 scaling points.)

6.1.2 USER INPUT / FUNCTION KEY PARAMETERS (USER)

This section details the programming for the rear terminal User Inputs and front panel Function Keys. Three user inputs are individually programmable to perform specific unit control functions. While in the Display Mode, the function is executed when the user input transitions to the active state. (Refer to the user input specifications for response times.) Certain User input functions are disabled in Programming Mode. Two front panel function keys, F1 and F2, are also individually programmable to perform specific unit control functions. While in the Display Mode, the primary function is executed when the key is pressed. Holding the F1 or F2 function key for three seconds executes a secondary function. It is possible to program a secondary function without a primary function. The front panel key functions are disabled while in Programming Mode.

In most cases, if more than one user input and/or function key is programmed for the same function, the maintained (level trigger) actions will be performed while at least one of those user inputs or function keys are activated. The momentary (edge trigger) actions are performed every time any of those user inputs or function keys transition to the active state.

The List user function has a value assignment sublist, which appears when the P key is pressed and LIST is selected. The function will only be performed for the assignment values selected as YES. If a user input or function key is configured for a function with a sublist, then that sublist will need to be scrolled through each time to access the remaining user inputs or function keys following the sublist.

Note: In the following explanations, not all selections are available for both user inputs and front panel function keys. Displays are shown with each selection. Those selections showing both displays are available for both. If a display is not shown, it is not available for that selection. In the parameter explanations, USER-n represents all user inputs. Fn represents both function keys and second function keys.

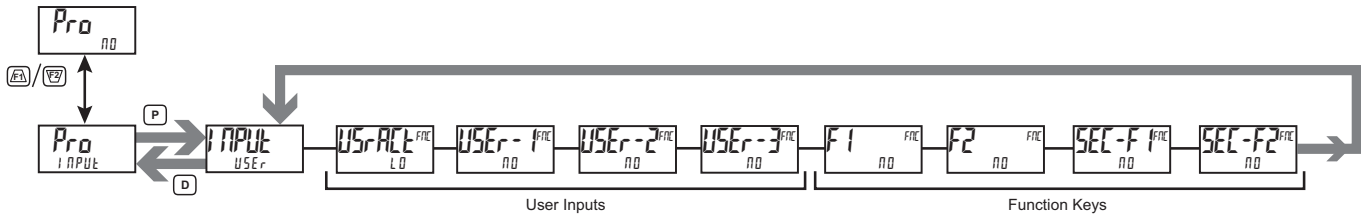

USER INPUT ACTIVE STATE



LO HI

Select the desired active state for the User Inputs. Select LO for sink input, active low. Select HI for source input, active high.

NO FUNCTION



No function is performed if activated. This is the factory setting for all user inputs and function keys.

PROGRAMMING MODE LOCK-OUT



Programming Mode is locked-out, as long as activated (maintained action). A security code can be configured to allow programming access during lock-out.

ZERO (TARE) DISPLAY



The Zero (Tare) Display provides a way to zero the Input Display value at various input levels, causing future relative input display readings to be offset. This function is useful in weighing applications where the container or material on the scale should not be included in the next measurement value. When activated (momentary action), *rESEt* flashes and the Display is set to zero. At the same time, the Display value (that was on the display before the Zero Display) is subtracted from the Display Tare Value and is automatically stored as the new Display Tare Value. If another Zero (tare) Display is performed, the display again changes to zero and the Display Tare Value shifts accordingly.

RESET TARE VALUE



The Reset Tare provides a way to zero the Display Tare (offset) value, eliminating the Tare (offset) from the relative display. When activated (momentary action), *rESEt* flashes and the Display Tare value is set to zero. Following a Reset Tare, the Input display (relative) value will match the Gross (absolute).

RELATIVE/GROSS (ABSOLUTE) VALUE

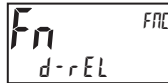

This function will switch the Input Display between Relative and Gross (Absolute) value. The Relative is a net value that includes the Display Tare (Offset) Value. The Input Display will show the Relative unless switched by this function. The Gross is an absolute value (based on Input (Analog) Module *d5P* and *!AP* entries) without the Display Tare (Offset) Value. The Gross value is selected as long as the user input is activated (maintained action) or at the transition of the function key (momentary action). When the user input is released, or the function key is pressed again, the input display switches back to Relative value. *Gr055* (gross) or *rEL* (relative) is momentarily displayed at transition to indicate which value is being displayed.

HOLD DISPLAY



The active display is held but all other unit functions continue as long as activated (maintained action).

HOLD ALL FUNCTIONS



The unit disables processing the input, holds all display contents, and locks the state of all outputs as long as activated (maintained action). The serial port continues data transfer.

SYNCHRONIZE METER READING



The unit suspends all functions as long as activated (maintained action). When the user input is released, the unit synchronizes the restart of the A/D converter input sampling with other processes or timing events.

STORE BATCH READING IN TOTALIZER



The Input Display value is added (batched) to the Totalizer when activated (momentary action) and the display flashes *bAtch*. The Totalizer retains a running sum of each batch operation until the Totalizer is reset. When this function is selected, the normal operation of the Totalizer is overridden and only batched Input Display values accumulate in the Totalizer.

SELECT TOTALIZER DISPLAY



The Totalizer appears on Line 2 as long as activated (maintained action). When the user input is released, the previously selected display is returned. The **D** or **P** keys override and disable the active user input. The Totalizer continues to function including associated outputs independent of the selected display.

RESET TOTALIZER



When activated (momentary action), *rESEt* flashes and the Totalizer resets to zero. The Totalizer then continues to operate as it is configured. This selection functions independent of the selected display.

RESET AND ENABLE TOTALIZER



When activated (momentary action), *rESEt* flashes and the Totalizer resets to zero. The Totalizer continues to operate while active (maintained action). When the user input is released, the Totalizer stops and holds its value. This selection functions independent of the selected display.

ENABLE TOTALIZER



The Totalizer continues to operate while active (maintained action). When the user input is released, the Totalizer stops and holds its value. This selection functions independent of the selected display.

SELECT MAXIMUM DISPLAY



The Maximum display appears on Line 2 as long as activated (maintained). When the user input is released, the previously selected display is returned. The **D** or **P** keys override and disable the active user input. The Maximum continues to function independent of the selected display.

RESET MAXIMUM DISPLAY

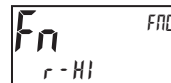

When activated (momentary action), *rESEt* flashes and the Maximum resets to the present Input Display value. The Maximum function then continues from that value. This selection functions independent of the selected display.

SELECT MINIMUM DISPLAY



The Minimum display appears on Line 2 as long as activated (maintained). When the user input is released, the previously selected display is returned. The **D** or **P** keys override and disable the active user input. The Minimum continues to function independent of the selected display.

RESET MINIMUM DISPLAY



When activated (momentary action), *rESEt* flashes and the Minimum resets to the present Input Display value. The Minimum function then continues from that value. This selection functions independent of the selected display.

RESET MAXIMUM AND MINIMUM DISPLAY

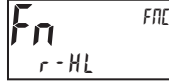

When activated (momentary action), *rESEt* flashes and the Maximum and Minimum readings are set to the present Input Display value. The Maximum and Minimum function then continues from that value. This selection functions independent of the selected display.

SELECT LINE 1 DISPLAY



When activated (momentary action), the display advances to the next Line 1 display that has been made available (in the Display Module, Line 1/Select sub-menu).

SELECT LINE 2 DISPLAY



When activated (momentary action), the display advances to the next Line 2 display that has been made available (in the Display Module, Line 2/Access sub-menu).

ADJUST DISPLAY INTENSITY



When activated (momentary action), the display intensity changes to the next intensity level.

CHANGE DISPLAY COLOR



When activated (momentary action), Line 1 will change color green to red, red to orange, orange to green.

SELECT PARAMETER LIST



Two lists of values are available to allow the user to either switch between two sets of setpoints, or setpoints and scaling parameters and/or Line 1 & 2 mnemonics (if enabled).

The two lists are named *LIST-A* and *LIST-B*. If a user input is used to select the list then *LIST-A* is selected when the user input is not active and *LIST-B* is selected when the user input is active (maintained action). If a front panel key is used to select the list then the list will toggle for each key press (momentary action). The display will indicate which list is active when the list is changed, at power-up, and when entering the Parameter loop (if enabled) or Programming menus.

To program the values for *LIST-A* and *LIST-B*, first complete the programming of all the parameters. Exit programming and switch to the other list. Re-enter programming and enter the desired values for various parameters included in the list.

Two sub-menus are used to select whether scaling parameters and the custom units mnemonics are included in the list function. When the *SCALE* sub-menu is selected as *YES*, the following parameters are also included in the A/B parameter lists:

- Scaling Points 1-16
- Input Decimal Point
- Input Filter Band
- Input Rounding Factor
- Totalizer Scale Factor
- Totalizer Decimal point

When the list is changed, the Offset (tare) value and internal Auto-zero buffer value (if Number of scaling points = 2) are also converted to the new units.

When the *UNIT5* sub-menu is selected as *YES*, the Custom Units mnemonics are included in A/B parameter list. Using the *LIST* function and enabling *SCALE* & *UNIT5* provides the ability to use the PAX2 to read-out and display in 2 different engineering units (i.e., pounds and kilograms).

SUB-MENU	DESCRIPTION	FACTORY
<i>SCALE</i>	Include Scaling Parameters	<i>NO</i>
<i>UNIT5</i>	Include Units mnemonics	<i>NO</i>

SETPOINT SELECTIONS



- r-1* - Reset Setpoint 1 (Alarm 1)
- r-2* - Reset Setpoint 2 (Alarm 2)
- r-3* - Reset Setpoint 3 (Alarm 3)
- r-4* - Reset Setpoint 4 (Alarm 4)
- r-34* - Reset Setpoint 3 & 4 (Alarm 3 & 4)
- r-234* - Reset Setpoint 2, 3 & 4 (Alarm 2, 3 & 4)
- r-ALL* - Reset All Setpoints (Alarms 1-4)

PRINT REQUEST



The unit issues a block print through the serial port when activated, and the serial type is set to *rL*. The data transmitted during a print request and the serial type is programmed in Port (Serial) module. If the user input is still active after the transmission is complete (about 100 msec), an additional transmission occurs. As long as the user input is held active, continuous transmissions occur.

6.2 OUTPUT PARAMETERS (OUTPUT)

OUTPUT SELECT



SETPNT ANALOG

Select the Setpoint or Analog output to be programmed. The Analog output selection only appears if an analog output option card is installed in the unit.

6.2.1 SETPOINT OUTPUT PARAMETERS (SETPNT)

This section details the programming for the setpoints. To have output capabilities, a setpoint Option card needs to be installed into the PAX2S (see Ordering Information). Depending on the card installed, there will be two or four setpoint outputs available. If no output card is installed, programming for the setpoints is still available. An Exchange Parameter Lists feature for setpoint values is explained in User Input programming.

The Setpoint Assignment and Setpoint Output Action determine certain setpoint feature availability. The Setpoint Parameter Availability chart illustrates this.

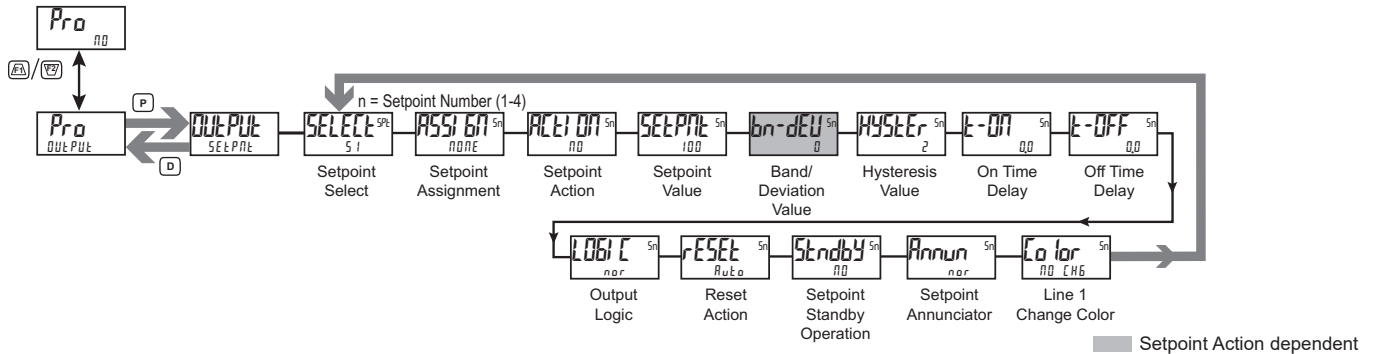

SETPOINT SELECT



51 52 53 54

Select the Setpoint output to be programmed. The "5n" in the following parameters will reflect the chosen setpoint number. After the chosen setpoint is completely programmed, the display returns to the Setpoint Select menu. Repeat steps for each setpoint to be programmed.

The number of outputs available is setpoint output card dependent (2 or 4). If no output card is installed, programming is still available for all 4 setpoints. This allows the Line 1 color change feature to provide a visual indication when a setpoint value has been reached, even if no setpoint output is being used.

SETPOINT ASSIGNMENT



NONE rEL Gross tOTAL

Selects the unit value to be used to trigger the Setpoint Alarm. The *rEL* setting will cause the setpoint to trigger off of the relative (net) input value. The relative input value is the absolute input value plus the Display Tare (Offset) Value. The *Gross* setting will cause the setpoint to trigger off of the gross (absolute) input value. The gross input value is based on the Input (Analog) module *dSP* and *INP* entries.

SETPOINT ACTION



NO Ab-HI Ab-LO AU-HI
AU-LO dE-HI dE-LO bAND
bAND n tOtLo tOtH

Enter the action for the selected setpoint (alarm output). See Setpoint Alarm Figures for a visual detail of each action. The Setpoint Actions that pertain to the total is only active when the Setpoint Assignment is set to *tOTAL*.

- NO* = No Setpoint Action
- Ab-HI* = Absolute high, with balanced hysteresis
- Ab-LO* = Absolute low, with balanced hysteresis
- AU-HI* = Absolute high, with unbalanced hysteresis
- AU-LO* = Absolute low, with unbalanced hysteresis
- dE-HI* = deviation high, with unbalanced hysteresis

- dE-LO* = deviation low, with unbalanced hysteresis
- bAND* = Outside band, with unbalanced hysteresis
- bAND n* = Inside band, with unbalanced hysteresis
- tOtLo* = Lower 6 digits of 9 digit Totalizer, with unbalanced hysteresis
- tOtH* = Upper 6 digits of 9 digit Totalizer, with unbalanced hysteresis

SETPOINT VALUE



- 199999 to 999999

Enter desired setpoint alarm value. Setpoint values can also be entered in the Display Mode during Program Lockout when the setpoint is programmed as *Enter* in the Display (Line 2) Access parameters. The decimal point position is determined by the Setpoint Assignment value.

BAND/DEVIATION VALUE



- 199999 to 999999

This parameter is only available in band and deviation setpoint actions. Enter desired setpoint band or deviation value. When the Setpoint Action is programmed for Band, this value can only be a positive value.

HYSTERESIS VALUE



1 to 65000

Enter desired hysteresis value. See Setpoint Alarm Figures for visual explanation of how setpoint alarm actions (balanced and unbalanced) are affected by the hysteresis. When the setpoint is a control output, usually balanced hysteresis is used. For alarm applications, usually unbalanced hysteresis is used. For unbalanced hysteresis modes, the hysteresis functions on the low side for high acting setpoints and functions on the high side for low acting setpoints. Note: Hysteresis eliminates output chatter at the switch point, while time delay can be used to prevent false triggering during process transient events.

Setpoint Alarm Figures

With reverse output logic $r\epsilon u$, the below alarm states are opposite.

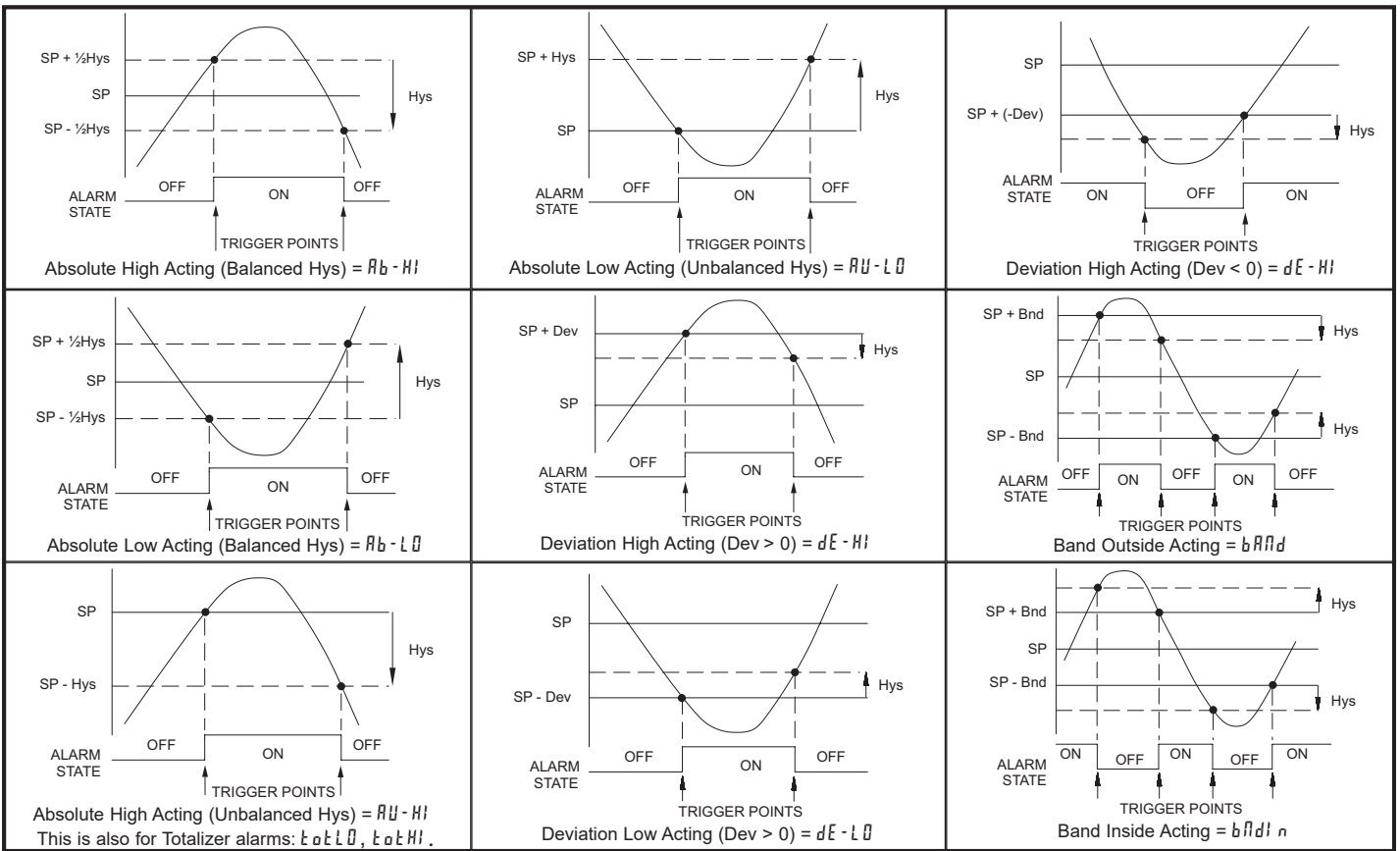

ON TIME DELAY



0.0 to 3275.0 seconds

Enter the time value in seconds that the alarm is delayed from turning on after the trigger point is reached. A value of 0.0 allows the unit to update the alarm status per the response time listed in the Specifications. When the output logic is $r\epsilon u$, this becomes off time delay. Any time accumulated at power-off resets during power-up.

OFF TIME DELAY



0.0 to 3275.0 seconds

Enter the time value in seconds that the alarm is delayed from turning off after the trigger point is reached. A value of 0.0 allows the unit to update the alarm status per the response time listed in the Specifications. When the output logic is $r\epsilon u$, this becomes on time delay. Any time accumulated at power-off resets during power-up.

OUTPUT LOGIC



nor $r\epsilon u$

Enter the output logic of the alarm output. The nor logic leaves the output operation as normal. The $r\epsilon u$ logic reverses the output logic. In $r\epsilon u$, the alarm states in the Setpoint Alarm Figures are reversed.

RESET ACTION



Auto Latch1 Latch2

Enter the reset action of the alarm output.

$Auto$ = Automatic action; This action allows the alarm output to automatically reset at the trigger points per the Setpoint Action shown in Setpoint Alarm Figures. The "on" alarm may be manually reset immediately by a front panel function key or user input. The alarm remains reset until the trigger point is crossed again.

$Latch1$ = Latch with immediate reset action; This selection latches the alarm output on at the trigger point per the Setpoint Action shown in Setpoint Alarm Figures. Latch means that the alarm output can only be turned off by front panel function key or user input manual reset, serial reset command or unit power cycle. When the user input or function key is activated (momentary or maintained), the corresponding "on" alarm output is reset immediately and remains off until the trigger point is crossed again. (Previously latched alarms will be off if power up Display Value is lower than setpoint value.)

$Latch2$ = Latch with delay reset action; This selection latches the alarm output on at the trigger point per the Setpoint Action shown in Setpoint Alarm Figures. Latch means that the alarm output can only be turned off by front panel function key or user input manual reset, serial reset command or unit power cycle. When the user input or function key is activated (momentary or maintained), the unit delays the reset event until the corresponding "on" alarm output crosses the trigger off point. (Previously latched alarms are off if power up Display Value is lower than setpoint value. During a power cycle, the unit erases a previous Latch 2 reset if it is not activated at power up.)

SETPOINT STANDBY OPERATION



no YES

When YES , the alarm is disabled (at power up) until the trigger point is crossed.

SETPOINT ANNUNCIATOR

Annun^{Sn}
nor

nor rEu FLASH OFF

The *nor* mode displays the corresponding setpoint annunciators of “on” alarm outputs. The *rEu* mode displays the corresponding setpoint annunciators of “off” alarms outputs. The *FLASH* mode flashes the corresponding setpoint annunciators of “on” alarm outputs. The *OFF* mode disables display setpoint annunciators.

LINE 1 CHANGE COLOR

Color^{Sn}
noChg

noChg BrEEN OrANGE rEd
BrnOrb rEdOrb rEdGrn LINE 1

This parameter allows the Line 1 Display to change color, or alternate between two colors, when the alarm is activated. When multiple alarms are programmed to change color, the highest numbered active alarm (S4-S1) determines the display color.

The *noChg* selection will maintain the color displayed prior to the alarm activation. The *LINE 1* selection sets the display to the Display (Line 1) Color (*Color*).

6.2.2 ANALOG OUTPUT PARAMETERS (ANALOG)

This section is only accessible with the optional PAXCDL Analog card installed (see Ordering Information).

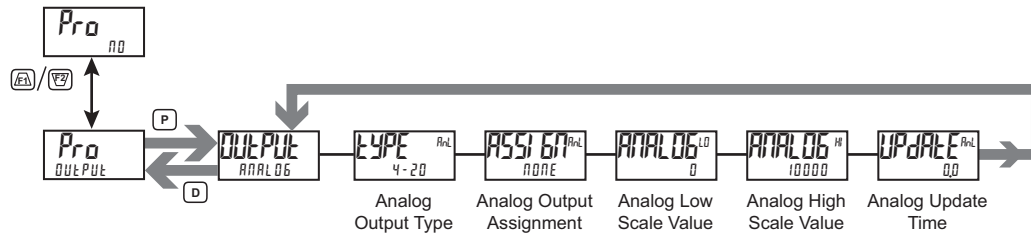

ANALOG OUTPUT TYPE

TYPE^{RnL}
4-20

4-20 0-10 0-20

Enter the analog output type. For 0-20 mA or 4-20 mA use terminals 18 and 19. For 0-10 V use terminals 16 and 17. Only one range can be used at a time.

ANALOG LOW SCALE VALUE

ANALOG^{LO}
0

- 999999 to 999999

Enter the Display Value that corresponds to 0 mA (0-20 mA) , 4 mA (4-20 mA) or 0 VDC (0-10 VDC).

ANALOG OUTPUT ASSIGNMENT

ASSIGN^{RnL}
none

none rEL Br055 tOTAL HI
LO 51 52 53 54

Enter the source for the analog output to retransmit:

- none* = Manual Mode operation. (See Serial RLC Protocol in the Communications Port module).
- rEL* = Relative (net) Input Value. The Relative Input Value is the Gross (Absolute) Input Value that includes the Display Tare (Offset) Value.
- Br055* = Gross (Absolute) Input Value. The Gross Input Value is based on the Input (Analog) module *d5P* and *iRP* entries.
- tOTAL* = Totalizer Value
- HI* = Maximum Display Value
- LO* = Minimum Display Value
- 51-54* = Setpoint Values

ANALOG HIGH SCALE VALUE

ANALOG^{HI}
10000

- 999999 to 999999

Enter the Display Value that corresponds to 20 mA (0-20 mA) , 20 mA (4-20 mA) or 10 VDC (0-10 VDC).

ANALOG UPDATE TIME

UPDATE^{RnL}
0.0

0.0 to 10.0

Enter the analog output update rate in seconds. A value of 0.0 allows the unit to update the analog output at the ADC Conversion Rate.

6.3 DISPLAY PARAMETERS (d SPLY)

DISPLAY SELECT



LINE 1 LINE 2 SCrDrY tOTAL

Select the Display to be programmed.

6.3.1 LINE 1 PARAMETERS (LINE 1)

This section details programming for the Line 1 (Top Line) Display. The Input, Gross, Tare, Total, Maximum (HI) and Minimum (LO) capture values and setpoints can be shown on the Line 1 display. The 3-digit Units mnemonic characters can be used to indicate which Line 1 display value is shown. Standard mnemonics are available for Setpoints 1-4. Standard or custom mnemonics are available for all other Line 1 values.

Main Display Loop

In the Main display loop, the selected values can be consecutively read on Line 1 by activating a user input or function key programmed as SEL L1. Each time the user input/function key is activated, Line 1 display will change to the next enabled Line 1 display value. Line 1 can also be programmed for Scroll, which will cause Line 1 to automatically scroll through all of the selected Line 1 display values.

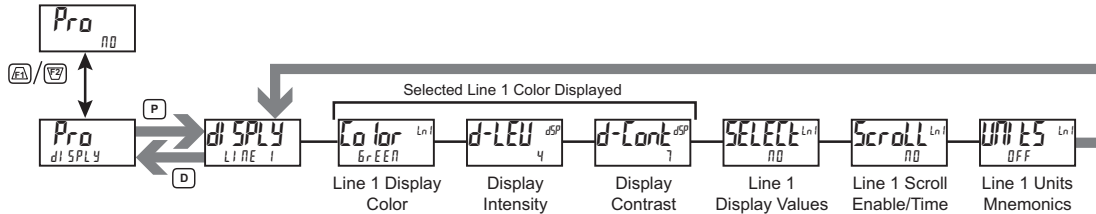

LINE 1 DISPLAY COLOR



GREEN rEd ORANGE

Enter the desired Display Line 1 and programmable Units Display color.

LINE 1 DISPLAY SCROLL ENABLE/TIME



NO 1 to 15 seconds

If Line 1 Display Scrolling is desired, set the scroll time in seconds.

DISPLAY INTENSITY LEVEL



0 to 4

Enter the desired Display Intensity Level (0-4) by using the arrow keys. The display will actively dim or brighten as the levels are changed. This parameter can also be accessed in the Parameter display loop when enabled.

DISPLAY CONTRAST LEVEL



0 to 15

Enter the desired Display Contrast Level (0-15) by using the arrow keys. The display contrast / viewing angle will actively adjust up or down as the levels are changed. This parameter can also be accessed in the Parameter display loop when enabled.

LINE 1 UNITS MNEMONIC(S)



OFF LABEL CUSt FACt

Select the mode for Line 1 Units Mnemonic(s). See LINE 1 UNITS MNEMONIC DIAGRAM for programming details.

SELECTION	MODE	DESCRIPTION
OFF	OFF	No Line 1 mnemonic shown.
LABEL	LABEL	Single programmable mnemonic shown for all Line 1 values.
CUSt	CUSTOM	Custom programmable mnemonics shown for each Line 1 value.
FACt	FACTORY	Factory default mnemonics shown for each Line 1 value.

The characters available for the programmable modes include:

A B C D E F G H I J K L M N O P Q R S T U V W X Y Z 0 1
2 3 4 5 6 7 8 9 a c e g h i n o q r u - = [/ ° . blank

Two character spaces are required to display this character.

LINE 1 DISPLAY VALUE SELECT/ENABLE



NO YES

Enter YES to select which values will be shown on the Line 1 display. A sub-menu provides Yes/No selection for each available Line 1 value. Values set to YES in the sub-menu will be displayable on Line 1.

DISPLAY	DESCRIPTION	FACTORY
INPUT	Input	YES
GROSS	Gross (absolute)	NO
TARE	Tare	NO
TOTAL	Total	NO
HI	Max value	NO
LO	Min value	NO
S1	Setpoint 1	NO
S2	Setpoint 2	NO
S3	Setpoint 3	NO
S4	Setpoint 4	NO

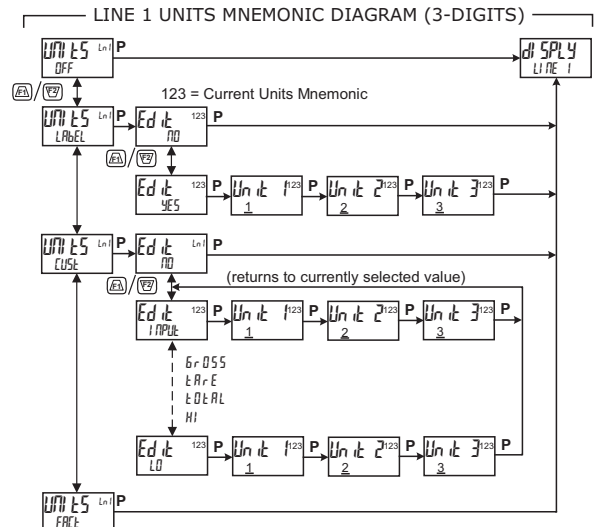

6.3.2 LINE 2 PARAMETERS (LINE 2)

This section details programming for the Line 2 (Bottom Line) Display. The Input, Gross, Tare, Total, Max, Min, Setpoint, Band/Deviation values and Parameter List A/B status can be shown on the Line 2 display. The display loops described below are used to view, reset and modify the selected display values, based on the Line 2 Value Access setting programmed for each available value.

Main Display Loop

In the Main display loop, the selected values can be consecutively read on Line 2 by pressing the **D** key. A left justified 2, 3 or 4-character mnemonic indicates which Line 2 value is currently shown. When in the Main display loop, the Function keys **F1** and **F2** perform the User functions programmed in the User Input program section.

Parameter Display Loop and Hidden Parameter Loop

These display loops provide quick access to selected parameters that can be viewed and modified on Line 2 without having to enter Full Programming Mode. These values include Parameter List A/B selection, Setpoints and Display Settings (color, intensity and contrast). To utilize the Parameter or Hidden Parameter display loops, a security code (1-250) must be programmed. (See Programming Security Code at the end of this section.)

The Parameter display loop is accessed by pressing the **P** key. The selected Parameter display loop values can be viewed and/or changed per the Line 2 Value Access setting programmed for each available value. The Hidden Parameter loop follows the Parameter display loop, and can only be accessed when the correct security code is entered at the Code prompt.

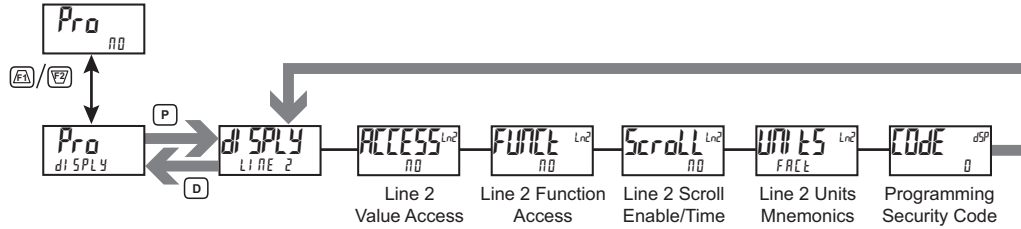

LINE 2 VALUE ACCESS



Select **YES** to program the Value Access setting for each available Line 2 parameter. Line 2 values can be made accessible in either the Main (**D** key), Parameter (**P** key) or Hidden (**P** key following code entry) display loops. When the List parameter is configured for an **Enter** setting, a List assignment sub-menu will follow. Refer to Input module, User sub-menu section for a description of the function.

Each parameter must be configured for one of the following settings. Not all settings are available for each parameter, as shown in the Parameter Value Access table.

SELECTION	DESCRIPTION
LDC	Not viewed on Line 2 Display (Factory Default Setting)
d-rERd	View in Main display loop. Cannot change or reset.
d-rSt	View and reset in Main display loop.
d-Ent r	View and change in Main display loop
P-rERd	View in Parameter display loop. Cannot change or reset.
P-Ent r	View and change in Parameter display loop
H idE	View and change in Hidden Parameter display loop

LINE 2 FUNCTIONS ACCESS



Select **YES** to display the following list of functions that can be made available at the end of the Parameter (**P-Enter**) or Hidden (**H idE**) display loops. Each Line 2 Function can be programmed for **LDC**, **P-Enter**, or **H idE**.

The more critical and frequently used functions should be first assigned to the User Inputs and User Function keys, however if more functions are needed than what can be obtained with user inputs and function keys, these will provide a means to provide that access. Refer to Input module, User sub-menu section for a description of the function.

SELECTION	DESCRIPTION
rEl	Zero (tare) display
r-tArE	Reset Display Tare (offset) value
bAt	Store batch reading in Totalizer
r-tot	Reset Totalizer
r-HI	Reset Maximum value
r-LO	Reset Minimum value
r-HL	Reset Max and Min values
r-i	Reset Setpoint output 1

LINE 2 PARAMETER VALUE ACCESS

DISPLAY	DESCRIPTION	NOT VIEWED	MAIN DISPLAY LOOP (D KEY)			PARAMETER DISPLAY LOOP (P KEY)		HIDDEN LOOP
			LDC	d-rERd	d-rSt	d-Ent r	P-rERd	
INPUT	Input	X	X	X				
GROSS	Gross (absolute)	X	X					
TARE	Tare Value	X	X		X			
TOTAL	Total	X	X	X				
Hi	Max Value	X	X	X				
Lo	Min Value	X	X	X				
LIST	Parameter List A/B	X	X		X	X	X	X
Sn	Setpoint Value (S1-S4) *	X	X		X	X	X	X
bn-dn	Band/Deviation	X	X		X	X	X	X
Color	Line 1 Display Color	X				X	X	X
d-LEU	Display Intensity Level	X				X	X	X
d-CONt	Display Contrast Level	X				X	X	X

* Indicates multiple value entries.

6.3.3 SECONDARY FUNCTION PARAMETERS (SENdry)

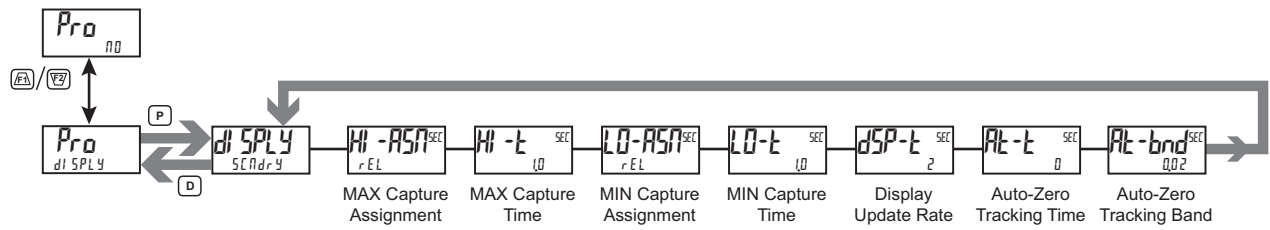

MAX (HI) CAPTURE ASSIGNMENT

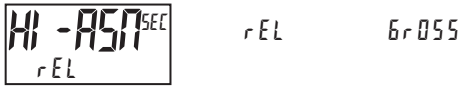

Select the desired input value that will be assigned to the Max Capture.

MAX (HI) CAPTURE DELAY TIME



When the Input value is above the present MAX value for the entered delay time, the unit will capture that value as the new MAX reading. A delay time helps to avoid false captures of sudden short spikes.

MIN (LO) CAPTURE ASSIGNMENT

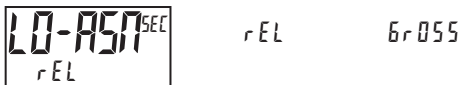

Select the desired input value that will be assigned to the Min Capture.

MIN (LO) CAPTURE TIME



When the Input value is below the present MIN value for the entered delay time, the unit will capture that value as the new MIN reading. A delay time helps to avoid false captures of sudden short spikes.

DISPLAY UPDATE RATE



This parameter configures the display update rate. It does not affect the response time of the setpoint output or analog output option cards.

AUTO-ZERO TRACKING TIME

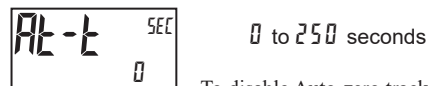

To disable Auto-zero tracking, set this value to 0.

AUTO-ZERO TRACKING BAND



The unit can be programmed to automatically compensate for zero drift. Drift may be caused by changes in the transducers or electronics, or accumulation of material on weight systems.

Auto-zero tracking operates when the readout remains within the tracking band for a period of time equal to the auto-zero tracking time. When these conditions are met, the unit re-zeroes the readout. After the re-zero operation, the unit resets and continues to auto-zero track.

The auto-zero tracking band should be set large enough to track normal zero drift, but small enough to not interfere with small process inputs.

For filling operations, the fill rate must exceed the auto-zero tracking rate. This avoids undesirable tracking at the start of the filling operation.

$$\text{Fill Rate} \geq \frac{\text{tracking band}}{\text{tracking time}}$$

Auto-zero tracking is disabled by setting the auto-zero tracking time parameter = 0.

6.3.4 TOTALIZER (INTEGRATOR) PARAMETERS (TOTAL)

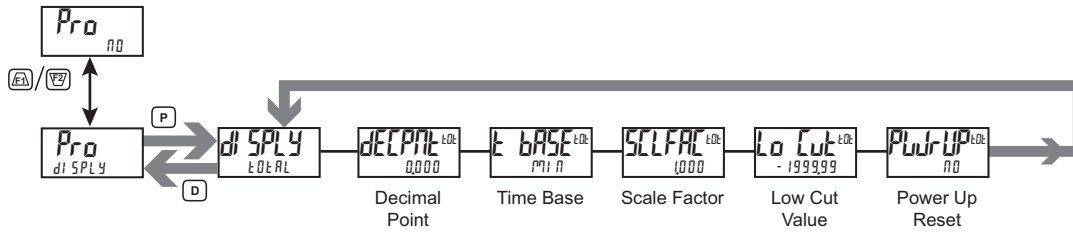

The totalizer accumulates (integrates) the Relative Input Display value using one of two modes. The first is using a time base. This can be used to provide an indication of total flow, usage or consumption over time. The second is through a user input or function key programmed for Batch (one time add on demand). This can be used to provide a readout of total weight, useful in weight based filling operations. If the Totalizer is not needed, its display can be locked-out and this module can be skipped during programming.

TOTALIZER DECIMAL POINT



For most applications, this should match the Input Display Decimal Point (diSPly). If a different location is desired, refer to Totalizer Scale Factor.

TOTALIZER TIME BASE

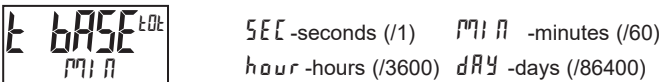

This is the time base used in Totalizer accumulations. If the Totalizer is being accumulated through a user input programmed for Batch, then this parameter does not apply.

TOTALIZER SCALE FACTOR



For most applications, the Totalizer reflects the same decimal point location and engineering units as the Input Display. In this case, the Totalizer Scale Factor is 1.000. The Totalizer Scale Factor can be used to scale the Totalizer to a value that is different than the Input Display. Common possibilities are:

1. Changing decimal point location (example tenths to whole)
2. Average over a controlled time frame.

Details on calculating the scale factor are shown later.

If the Totalizer is being accumulated through a user input programmed for Batch, then this parameter does not apply.

TOTALIZER LOW CUT VALUE

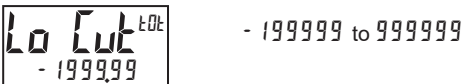

A low cut value disables Totalizer when the Input Display value falls below the value programmed.

TOTALIZER POWER UP RESET



The Totalizer can be reset to zero on each unit power-up by setting this parameter to YES.

TOTALIZER BATCHING

The Totalizer Time Base is overridden when a user input or function key is programmed for store batch (bAt). In this mode, when the user input or function key is activated, the Input Display reading is multiplied by the totalizer scale factor and then one time added to the Totalizer (batch). The Totalizer retains a running sum of each batch operation until the Totalizer is reset. This is useful in weighing operations, when the value to be added is not based on time but after a filling event.

TOTALIZER USING TIME BASE

Totalizer accumulates as defined by:

$$\text{Totalizer Scale Factor} = \frac{\text{Totalizer Display}^*}{\text{Input Display}^*}$$

*Value indicated with decimal and all display units after the decimal; Prior to calculating, "drop" the decimal leaving all trailing units.

Where:

Input Display = Fixed Input Display value.

Totalizer Display = Totalized value with Input Display constant during a period of time equal to the Totalizer Time Base.

Example: A PAX2S is monitoring the total weight of material on a 20 ft conveyor. The conveyor operates at a constant rate of 1 ft/sec. The Totalizer will calculate the total weight of material output from the conveyor. Although the PAX2S Input Display indicates lbs in whole units, the Totalizer will be programmed to display tons in 1/10 units. Note that this application requires a User Input to enable the Totalizer when the conveyor is running. Accuracy is dependent on the amount of material and position of material still on the conveyor. For accurate totalizer reading, the conveyor should be allowed to "empty" before taking a totalizer reading.

There are several factors to consider in this example. First, the material that clears the end of the conveyor in 1 second is only 1/20 of the weight being displayed at any given time (20 ft conveyor @ 1 ft/sec). Second, the Totalizer display is in tenths of tons, while the input is in pounds.

In order to calculate the Totalizer Scale Factor, choose a constant Input Display (100) value and then determine the Totalizer Display value that would result after the period of the Totalizer Time Base (1 hour) selected.

$$\frac{100 \text{ lb}}{20 \text{ sec}} = 5 \text{ lb/sec.} \rightarrow \text{With 100 lb on the conveyor, 5 lbs falls off the end of the conveyor each second.}$$

$$5 \text{ lb/sec} \times 3600 \text{ sec} = 18,000 \text{ lb} \rightarrow \text{3600 seconds of material passing the end of the conveyor in an hour.}$$

$$\frac{18,000 \text{ lb}}{2000 \text{ lb}} = 9.0 \text{ tons} \rightarrow \text{Conversion of lbs to tons.}$$

Conclusion: Input Display of 100 results in a Totalizer Display of 9.0 after 1 hour of constant and continuous operation. Place these values in the Totalizer Scale Factor formula as follows:

$$\begin{aligned} \text{Totalizer Scale Factor} &= \text{Totalizer Display}^* / \text{Input Display}^* \\ \text{Totalizer Scale Factor} &= 9.0/100 \\ \text{Totalizer Scale Factor} &= 90/100 \text{ **} \\ \text{Totalizer Scale Factor} &= 0.9 \end{aligned}$$

* This value should include the decimal and all display units after the decimal.

** This step requires that the decimal be "dropped", but all other digits remain.

6.4 COMMUNICATIONS PORT PARAMETERS (Port)

To select *SErIAL*, an optional communication card must be installed.

PORT SELECT



USB SERIAL

Select the Communications Port to be programmed.

USB PORT PARAMETERS (USB)

USB CONFIGURATION



AUTO SERIAL

AUTO Unit automatically configures USB port settings to operate with Crimson configuration software. When a USB cable is attached to PAX2S and PC, the port is internally set to Modbus RTU protocol, 38400 baud, 8 bits, and Unit Address 247. The Serial Port settings programmed below will not change, or show this.

SErIAL Configures USB port to utilize the Serial Port settings and protocol programmed below.

SERIAL PORT PARAMETERS (SErIAL)

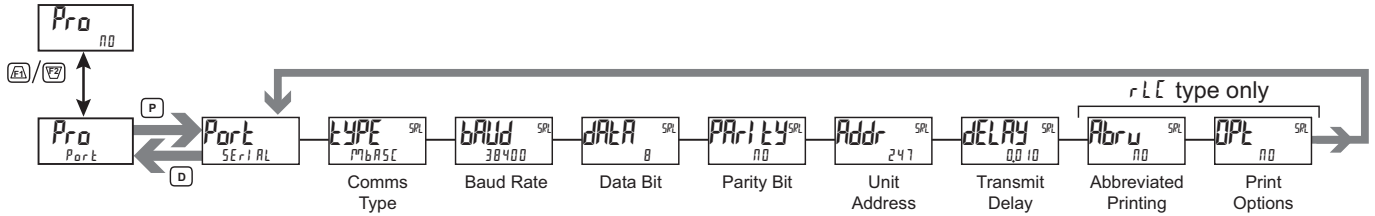

COMMUNICATIONS TYPE



- Modbus - Modbus RTU
- Modbus - Modbus ASCII
- RLC - RLC Protocol (ASCII)

Select the desired communications protocol. Modbus is preferred as it provides access to all unit values and parameters. Since the Modbus protocol is included within the PAX2S, the PAX Modbus option card, PAXCDC4, should not be used. The PAXCDC1 (RS485), or PAXCDC2 (RS232) card should be used instead.

PARITY BIT



- no
- EVEN
- odd

Set the parity bit to match that of the other serial communications equipment on the serial link. The unit ignores the parity when receiving data and sets the parity bit for outgoing data. If no parity is selected with 7 bit word length, an additional stop bit is used to force the frame size to 10 bits. Parity is automatically NO if *DATA* is set for 8 bit.

BAUD RATE



- | | | |
|------|------|-------|
| 1200 | 4800 | 19200 |
| 2400 | 9600 | 38400 |

Set the baud rate to match the other serial communications equipment on the serial link. Normally, the baud rate is set to the highest value that all the serial equipment are capable of transmitting and receiving.

UNIT ADDRESS

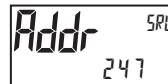

- 1 to 247 - Modbus
- 0 to 99 - RLC Protocol

Select a Unit Address that does not match an address number of any other equipment on the serial link.

DATA BIT



- 7
- 8

Select either 7 or 8 bit data word lengths. Set the word length to match the other serial communications equipment on the serial link. For *Modbus* communication type, data bit setting is fixed at 8 bits.

TRANSMIT DELAY



0.000 to 0.250 seconds

Following a Modbus command or RLC Transmit Value command, the PAX2S will wait this minimum amount of time in seconds before issuing a serial response

The following programming steps are only available when Communications Type (TYPE) is programmed for r L C .

PRINT OPTIONS



NO YES

ABBREVIATED PRINTING



NO YES

Select YES for full print or Command T transmissions (unit address, mnemonics and parameter data) or NO for abbreviated print transmissions (parameter data only). This will affect all the parameters selected in the print options. If the unit address is 00, it will not be sent during a full transmission.

YES - Enters the sub-menu to select the unit parameters to appear during a print request. For each parameter in the sub-menu, select YES for that parameter information to be sent during a print request or NO for that parameter information not to be sent. A print request is sometimes referred to as a block print because more than one parameter information (unit address, mnemonics and parameter data) can be sent to a printer or computer as a block.

DISPLAY	DESCRIPTION	FACTORY SETTING	MNEMONIC
INPUT	Signal Input	YES	INP
GROSS	Gross (absolute) Value	NO	GRS
TARE	Tare Value	NO	TAR
TOTAL	Total Value	NO	TOT
MAX & MIN	Max & Min	NO	MAX, MIN
SP4	Setpoint Values	NO	SP1-SP4

SERIAL COMMUNICATIONS OVERVIEW

The PAX2 supports serial communications using the optional serial communication cards or via the USB programming port located on the side of the unit. When USB is being used (connected), the serial communication card is disabled. When using the standard RS232 and RS485 PAX option cards, the PAX2 supports both the RLC protocol and also supports Modbus communications. The PAX Modbus option card should not be used with the PAX2, as the PAX2 internal Modbus protocol supports complete unit configuration, and is much more responsive.

USB

The USB programming port is primarily intended to be used to configure the PAX2S with the Crimson programming software. It can also be used as a virtual serial communications port following installation of the PAX2S USB drivers that are supplied with the Crimson software. When the USB port is being used, i.e. the USB cable is connected between PAX2S and PC, all serial communications with the serial option card (if used) is disabled.

USB Cable type required: USB A to Mini-B (not supplied)

PAX2S CONFIGURATION USING CRIMSON AND USB

1. Install Crimson software.
2. Supply power to PAX2S
3. Insure USB Configuration “`CONF15`” in USB Port Parameters is set to “`RTU`” (factory default setting).
4. Attach USB cable (USB A to Mini-B) between PC and PAX2S.
5. Create a new file (File, New) or open an existing PAX2S database within Crimson.
6. Configure Crimson Link options (Link, Options) to the serial port which the USB cable is attached (in Step 4).

SERIAL MODBUS COMMUNICATIONS

Modbus Communications requires that the Serial Communication Type Parameter (TYPE) be set to “`RTU`” or “`RS485`”.

PAX2S CONFIGURATION USING CRIMSON AND SERIAL COMMUNICATIONS CARD

1. Install Crimson software.
2. Install RS232 or RS485 card and connect communications cable from PAX2S to PC.
3. Supply power to PAX2S
4. Configure serial parameters (SERIAL) to Modbus RTU “`RTU`”, 38,400 baud, address 247.
5. Create a new file (File, New) or open an existing PAX2S database within Crimson.
6. Configure Crimson Link options (Link, Options) to the serial port which the communication cable is attached (in step 2).

SUPPORTED FUNCTION CODES

FC03: Read Holding Registers

1. Up to 64 registers can be requested at one time.
2. HEX <8000> is returned for non-used registers.

FC04: Read Input Registers

1. Up to 64 registers can be requested at one time.
2. Block starting point can not exceed register boundaries.
3. HEX <8000> is returned in registers beyond the boundaries.
4. Input registers are a mirror of Holding registers.

FC06: Preset Single Register

1. HEX <8001> is echoed back when attempting to write to a read only register.
2. If the write value exceeds the register limit (see Register Table), then that register value changes to its high or low limit. It is also returned in the response.

FC16: Preset Multiple Registers

1. No response is given with an attempt to write to more than 64 registers at a time.
2. Block starting point cannot exceed the read and write boundaries (1-1280).
3. If a multiple write includes read only registers, then only the write registers will change.
4. If the write value exceeds the register limit (see Register Table), then that register value changes to its high or low limit.

FC08: Diagnostics

The following is sent upon FC08 request:

Module Address, 08 (FC code), 04 (byte count), “Total Comms” 2 byte count, “Total Good Comms” 2 byte count, checksum of the string
 “Total Comms” is the total number of messages received that were addressed to the PAX2. “Total Good Comms” is the total messages received by the PAX2S with good address, parity and checksum. Both counters are reset to 0 upon response to FC08 and at power-up.

FC17: Report Slave ID

The following is sent upon FC17 request:

RLC-PAX2S ab<0100h><40h><40h><10h>
 a = SP Card, “0”-No SP, “2” or “4” SP
 b = Linear Card “0” = None, “1” = Yes
 <0100> Software Version Number (1.00)
 <40h>Max Register Reads (64)
 <40h>Max Register Writes (64)
 <10h> Number Guid/Scratch Pad Regs (16)

SUPPORTED EXCEPTION CODES

01: Illegal Function

Issued whenever the requested function is not implemented in the unit.

02: Illegal Data Address

Issued whenever an attempt is made to access a single register that does not exist (outside the implemented space) or to access a block of registers that falls completely outside the implemented space.

03: Illegal Data Value

Issued when an attempt is made to read or write more registers than the unit can handle in one request.

07: Negative Acknowledge

Issued when a write to a register is attempted with an invalid string length.

PAX2S FREQUENTLY USED MODBUS REGISTERS

Only frequently used registers are shown below. The entire Modbus Register Table can be found at www.redlion.net.

The following is an example of the necessary query and corresponding response for holding register 2. In this example register 2 is the decimal value 123.

Query: 01 03 00 01 00 01 D5 CA

Response: 01 03 02 00 7B F8 67

Notes:

1. The PAX registers can be read as holding (4x) or input (3x) registers.
2. For a value spanning two registers, the portion of the value less than 65,535 will be in (Lo word) register and the portion of the value greater than 65,535 will continue into (Hi word) register. Negative values are represented by two's complement of the combined (Hi word) and (Lo word).
3. The PAX2 should not be powered down while parameters are being changed. Doing so may result in an in-complete write to the non-volatile memory and produce checksum errors.

REGISTER (4x)	HOLDING REGISTER NAME	LOW LIMIT	HIGH LIMIT	FACTORY SETTING	ACCESS	COMMENTS
1	Input Relative Value (Hi word)	-199999	999999	N/A	Read Only	Process value of present input level. This value is affected by Input Type, Resolution, Scaling, & Tare (Offset) Value. (Relative Value = Gross (Absolute) Input Value - Tare Value)
2	Input Relative Value (Lo word)					
3	Maximum Value (Hi word)	-199999	999999	N/A	Read/Write	Maximum Relative Input Capture Value obtained since having been reset.
4	Maximum Value (Lo word)					
5	Minimum Value (Hi word)	-199999	999999	N/A	Read/Write	Minimum Relative Input Capture Value obtained since having been reset.
6	Minimum Value (Lo word)					
7	Total Value (Hi word)	-199999	999999	0	Read/Write	Totalizer value
8	Total Value (Lo word)					
9	Setpoint 1 Value (Hi word)	-199999	999999	100	Read/Write	Active List (A or B)
10	Setpoint 1 Value (Lo word)					
11	Setpoint 2 Value (Hi word)	-199999	999999	200	Read/Write	Active List (A or B)
12	Setpoint 2 Value (Lo word)					
13	Setpoint 3 Value (Hi word)	-199999	999999	300	Read/Write	Active List (A or B)
14	Setpoint 3 Value (Lo word)					
15	Setpoint 4 Value (Hi word)	-199999	999999		Read/Write	Active List (A or B)
16	Setpoint 4 Value (Lo word)					
17	Setpoint 1 Band/Dev. Value (Hi word)	-199999	999999	0	Read/Write	Active List (A or B). Applicable only for Band or Deviation Setpoint Action.
18	Setpoint 1 Band/Dev. Value (Lo word)					
19	Setpoint 2 Band/Dev. Value (Hi word)	-199999	999999	0	Read/Write	Active List (A or B). Applicable only for Band or Deviation Setpoint Action.
20	Setpoint 2 Band/Dev. Value (Lo word)					
21	Setpoint 3 Band/Dev. Value (Hi word)	-199999	999999	0	Read/Write	Active List (A or B). Applicable only for Band or Deviation Setpoint Action.
22	Setpoint 3 Band/Dev. Value (Lo word)					
23	Setpoint 4 Band/Dev. Value (Hi word)	-199999	999999	0	Read/Write	Active List (A or B). Applicable only for Band or Deviation Setpoint Action.
24	Setpoint 4 Band/Dev. Value (Lo word)					
25	Setpoint Output Register (SOR)	0	15	0	Read/Write	Status of Setpoint Outputs. Bit State: 0 = Off, 1 = On. Bit 3 = SP1, Bit 2 = SP2, Bit 1 = SP3, Bit 0 = SP4. Outputs can only be activated/reset with this register when the respective bits in the Manual Mode Register (MMR) are set.
26	Manual Mode Register (MMR)	0	31	0	Read/Write	Bit State: 0 = Auto Mode, 1 = Manual Mode Bit 4 = SP1, Bit 3 = SP2, Bit 2 = SP3, Bit 1 = SP4, Bit 0 = Linear Output
27	Reset Output Register	0	15	0	Read/Write	Bit State: 1 = Reset Output, bit is returned to zero following reset processing; Bit 3 = SP1, Bit 2 = SP2, Bit 1 = SP3, Bit 0 = SP4
28	Analog Output Register (AOR)	0	4095	0	Read/Write	Functional only if Linear Output is in Manual Mode. (MMR bit 0 = 1) Linear Output Card written to only if Linear Out (MMR bit 0) is set.
29	Input Gross (Absolute) Value (Hi word)	-199999	999999	N/A	Read Only	Gross (absolute) value of present Input level. This value is affected by Input Type, Resolution, Scaling, but not affected by Offset Value
30	Input Gross (Absolute) Value (Lo word)					
31	Tare Value (Hi word)	-199999	999999	0	Read/Write	Relative Input Value (standard unit value) is the difference between the Gross (absolute) input value and the Tare value, i.e. Relative = Gross - Tare
32	Tare Value (Lo word)					

SERIAL RLC PROTOCOL COMMUNICATIONS

RLC Communications requires the Serial Communications Type Parameter (TYPE) be set to "rLL".

SENDING SERIAL COMMANDS AND DATA TO THE UNIT

When sending commands to the unit, a string containing at least one command character must be constructed. A command string consists of a command character, a value identifier, numerical data (if writing data to the unit) followed by a command terminator character * or \$. The <CR> is also available as a terminator when Counter C is in the SLAVE mode.

Command Chart

COMMAND	DESCRIPTION	NOTES
N	Node (Unit) Address Specifier	Address a specific unit. Must be followed by a two digit node address. Not required when address = 00.
T	Transmit Value (read)	Read a register from the unit. Must be followed by register ID character
V	Value Change (write)	Write to register of the unit. Must be followed by register ID character and numeric data.
R	Reset	Reset a register or output. Must be followed by register ID character.
P	Block Print Request	Initiates a block print output. Registers are defined in programming.

Command String Construction

The command string must be constructed in a specific sequence. The unit does not respond with an error message to invalid commands. The following procedure details construction of a command string:

- The first characters consist of the Node Address Specifier (N) followed by a 2 character address number. The address number of the unit is programmable. If the node address is 0, this command and the node address itself may be omitted. This is the only command that may be used in conjunction with other commands.
- After the optional address specifier, the next character is the command character.
- The next character is the Register ID. This identifies the register that the command affects. The P command does not require a Register ID character. It prints according to the selections made in print options.
- If constructing a value change command (writing data), the numeric data is sent next.
- All command strings must be terminated with the string termination characters *, \$ or when Counter C is set for slave mode <CR>. The unit does not begin processing the command string until this character is received. See Timing Diagram figure for differences between terminating characters.

Register Identification Chart

ID	VALUE DESCRIPTION	MNEMONIC	APPLICABLE COMMANDS/COMMENTS
A	Input (relative value)	INP	T, P, R (Reset command resets input to zero; tares)
B	Total	TOT	T, P, R (Reset command resets total to zero)
C	Max Input	MAX	T, P, R (Reset command resets Max to current reading)
D	Min Input	MIN	T, P, R (Reset command resets Min to current reading)
E	Setpoint 1	SP1	T, P, V, R (Reset command resets the setpoint output)
F	Setpoint 2	SP2	
G	Setpoint 3	SP3	
H	Setpoint 4	SP4	
I	Band/Deviation 1	BD1	T, V
J	Band/Deviation 2	BD2	T, V
K	Band/Deviation 3	BD3	T, V
L	Band/Deviation 4	BD4	T, V
M	Gross (Absolute) Input value	GRS	T, P
O	Tare (Offset) Value	TAR	T, P, R, V
U	Auto/Manual Register	MMR	T, V
W	Analog Output Register	AOR	T, V
X	Setpoint Register	SOR	T, V

Command String Examples:

- Node address = 17, Write 350 to Setpoint 1.
String: N17VE350\$
- Node address = 5, Read Input value.
String: N5TA*
- Node address = 0, Reset Setpoint 4 output.
String: RH*

Sending Numeric Data

Numeric data sent to the unit must be limited to 6 digits (-199999 to 999999). Leading zeros are ignored. Negative numbers must have a minus sign. The unit ignores any decimal point and conforms the number to the scaled resolution. (For example: the unit's scaled decimal point position = 0.0 and 25 is written to a register. The value of the register is now 2.5.)

Note: Since the unit does not issue a reply to value change commands, follow with a transmit value command for readback verification.

RECEIVING DATA FROM THE UNIT

Data is transmitted by the unit in response to either a transmit command (T), a print block command (P) or User Function print request. The response from the unit is either a full field transmission or an abbreviated transmission. The unit response mode is selected in Serial Port Parameters (*Rbru*).

Full Field Transmission (Address, Mnemonic, Numeric data)

Byte	Description
1, 2	2 byte Node Address field [00-99]
3	<SP> (Space)
4-6	3 byte Register Mnemonic field
7-18	2 byte data field, 10 bytes for number, one byte for sign, one byte for decimal point
19	<CR> carriage return
20	<LF> line feed
21	<SP>* (Space)
22	<CR>* carriage return
23	<LF>* line feed

* These characters only appear in the last line of a block print.

The first two characters transmitted are the node address, unless the node address assigned = 0, in which case spaces are substituted. A space follows the node address field. The next three characters are the register mnemonic.

The numeric data is transmitted next. The numeric field is 12 characters long (to accommodate the 10 digit totalizer), with the decimal point position floating within the data field. Negative values have a leading minus sign. The data field is right justified with leading spaces.

The end of the response string is terminated with a carriage return <CR> and <LF>. When block print is finished, an extra <SP><CR> <LF> is used to provide separation between the blocks.

Abbreviated Transmission (Numeric data only)

Byte	Description
1-12	12 byte data field, 10 bytes for number, one byte for sign, one byte for decimal point
13	<CR> carriage return
14	<LF> line feed
15	<SP>* (Space)
16	<CR>* carriage return
17	<LF>* line feed

* These characters only appear in the last line of a block print.

Unit Response Examples:

- Node address = 17, full field response, Input = 875
17 INP 875 <CR><LF>
- Node address = 0, full field response, Setpoint 2 = -250.5
SP2 -250.5<CR><LF>
- Node address = 0, abbreviated response, Setpoint 2 = 250, last line of block print
250<CR><LF><SP><CR><LF>

Auto/Manual Mode Register (MMR) ID: U

This register sets the controlling mode for the outputs. In Auto Mode (0) the unit controls the setpoint and analog output. In Manual Mode (1) the outputs are defined by the registers SOR and AOR. When transferring from auto mode to manual mode, the unit holds the last output value (until the register is changed by a write). Each output may be independently changed to auto or manual. In a write command string (VU), any character besides 0 or 1 in a field will not change the corresponding output mode.

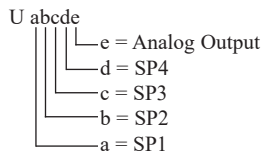

Example: VU00011 places SP4 and Analog in manual.

Analog Output Register (AOR) ID: W

This register stores the present signal value of the analog output. The range of values of this register is 0 to 4095, which corresponds to the analog output range per the following chart:

Register Value	Output Signal*		
	0-20 mA	4-20 mA	0-10 V
0	0.00	4.00	0.000
1	0.005	4.004	0.0025
2047	10.000	12.000	5.000
4094	19.995	19.996	9.9975
4095	20.000	20.000	10.000

*Due to the absolute accuracy rating and resolution of the output card, the actual output signal may differ 0.15% FS from the table values. The output signal corresponds to the range selected (0-20 mA, 4-20 mA or 0-10 V).

Writing to this register (VW) while the analog output is in the Manual Mode causes the output signal level to update immediately to the value sent. While in the Automatic Mode, this register may be written to, but it has no effect until the analog output is placed in the manual mode. When in the Automatic Mode, the unit controls the analog output signal level. Reading from this register (TW) will show the present value of the analog output signal.

Example: VW2047 will result in an output of 10.000 mA, 12.000 mA or 5.000V depending on the range selected.

Setpoint Output Register (SOR) ID: X

This register stores the states of the setpoint outputs. Reading from this register (TX) will show the present state of all the setpoint outputs. A "0" in the setpoint location means the output is off and a "1" means the output is on.

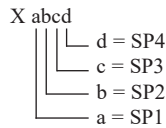

In Automatic Mode, the unit controls the setpoint output state. In Manual Mode, writing to this register (VX) will change the output state. Sending any character besides 0 or 1 in a field or if the corresponding output was not first in manual mode, the corresponding output value will not change. (It is not necessary to send least significant 0s.)

Example: VX10 will result in output 1 on and output 2 off.

COMMAND RESPONSE TIME

The unit can only receive data or transmit data at any one time (half-duplex operation). When sending commands and data to the unit, a delay must be imposed before sending another command. This allows enough time for the unit to process the command and prepare for the next command.

At the start of the time interval t_1 , the computer program prints or writes the string to the com port, thus initiating a transmission. During t_1 , the command characters are under transmission and at the end of this period, the command terminating character (*) is received by the unit. The time duration of t_1 is dependent on the number of characters and baud rate of the channel.

$$t_1 = (10 * \# \text{ of characters}) / \text{baud rate}$$

At the start of time interval t_2 , the unit starts the interpretation of the command and when complete, performs the command function. This time interval t_2 varies from 2 msec to 15 msec. If no response from the unit is expected, the unit is ready to accept another command.

If the unit is to reply with data, the time interval t_2 is controlled by the use of the command terminating character and the Serial Transmit Delay parameter (*dELAY*). The standard command line terminating character is “*”. This terminating character results in a response time window of the Serial Transmit Delay time (*dELAY*) plus 15 msec. maximum. The *dELAY* parameter should be programmed to a value that allows sufficient time for the release of the sending driver on the RS485 bus. Terminating the command line with “\$” results in a response time window (t_2) of 2 msec minimum and 15 msec maximum. The response time of this terminating character requires that sending drivers release within 2 msec after the terminating character is received.

At the beginning of time interval t_3 , the unit responds with the first character of the reply. As with t_1 , the time duration of t_3 is dependent on the number of characters and baud rate of the channel.

$$t_3 = (10 * \# \text{ of characters}) / \text{baud rate}$$

At the end of t_3 , the unit is ready to receive the next command. The maximum serial throughput of the unit is limited to the sum of the times t_1 , t_2 and t_3 .

Timing Diagrams

NO REPLY FROM UNIT

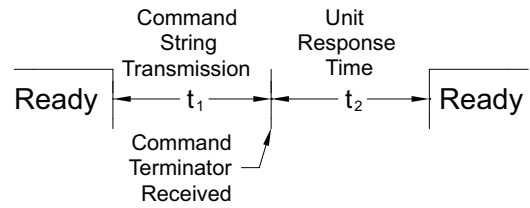

RESPONSE FROM UNIT

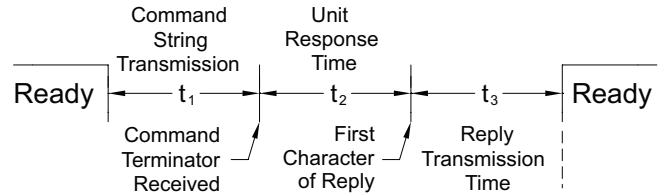

COMMUNICATION FORMAT

Data is transferred from the unit through a serial communication channel. In serial communications, the voltage is switched between a high and low level at a predetermined rate (baud rate) using ASCII encoding. The receiving device reads the voltage levels at the same intervals and then translates the switched levels back to a character.

The voltage level conventions depend on the interface standard. The table lists the voltage levels for each standard.

LOGIC	INTERFACE STATE	RS232*	RS485*
1	mark (idle)	TXD,RXD; -3 to -15 V	a-b < -200 mV
0	space (active)	TXD,RXD; +3 to +15 V	a-b > +200 mV

* Voltage levels at the Receiver

Data is transmitted one byte at a time with a variable idle period between characters (0 to ∞). Each ASCII character is “framed” with a beginning start bit, an optional parity bit and one or more ending stop bits. The data format and baud rate must match that of other equipment in order for communication to take place. The figures list the data formats employed by the unit.

Start bit and Data bits

Data transmission always begins with the start bit. The start bit signals the receiving device to prepare for reception of data. One bit period later, the least significant bit of the ASCII encoded character is transmitted, followed by the remaining data bits. The receiving device then reads each bit position as they are transmitted. Since the sending and receiving devices operate at the same transmission speed (baud rate), the data is read without timing errors.

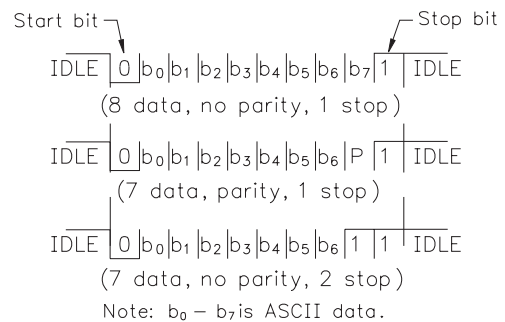

Character Frame Figure

Parity bit

After the data bits, the parity bit is sent. The transmitter sets the parity bit to a zero or a one, so that the total number of ones contained in the transmission (including the parity bit) is either even or odd. This bit is used by the receiver to detect errors that may occur to an odd number of bits in the transmission. However, a single parity bit cannot detect errors that may occur to an even number of bits. Given this limitation, the parity bit is often ignored by the receiving device. The PAX ignores the parity bit of incoming data and sets the parity bit to odd, even or none (mark parity) for outgoing data.

Stop bit

The last character transmitted is the stop bit. The stop bit provides a single bit period pause to allow the receiver to prepare to re-synchronize to the start of a new transmission (start bit of next byte). The receiver then continuously looks for the occurrence of the start bit. If 7 data bits and no parity is selected, then 2 stop bits are sent from the PAX.

6.5 FACTORY SERVICE OPERATIONS (FACTORY)

FACTORY SERVICE CODE



0-250

Enter the Service Code for the desired operation.

RESTORE FACTORY DEFAULTS



Use the $\overline{F1}$ and $\overline{F2}$ keys to display `CODE 66` and press **P**. The unit will flash `rESEt` and then return to `CODE 50`. Press the **P** key to return to Display Mode. This will overwrite all user settings with the factory settings. The only exception is the User Mnemonics which retain their programmed values (see Code 69).

RESTORE FACTORY DEFAULTS (w/Units Mnemonics)



Same as Code 66, except the User Mnemonics are also returned to the factory default settings (blank).

MODEL AND CODE VERSION

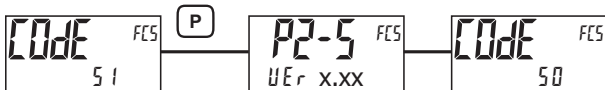

The unit will briefly display the model (`P25`) on Line 1, and the current firmware version (`UEr x.xx`) on Line 2, and then return to `CODE 50`.

CALIBRATION

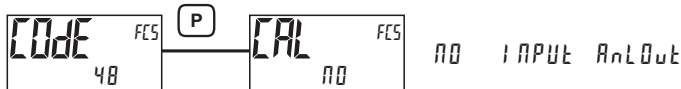

The unit has been fully calibrated at the factory. Scaling to convert the input signal to a desired display value is performed in Input Parameters. If the unit appears to be indicating incorrectly or inaccurately, refer to Troubleshooting before attempting to calibrate the unit. When recalibration is required (generally every 2 years), it should only be performed by qualified technicians using appropriate equipment. Calibration does not change any user programmed parameters. However, it will affect the accuracy of the input signal and the values previously stored using the Apply (`APPLY`) Scaling Style.

Preparation for Voltage Input Calibration



Warning: Input Calibration requires a signal source capable of producing a signal greater than or equal to the range being calibrated with an accuracy of 0.01% or better.

Before starting, verify that the Input Range Jumper is set for the range to be calibrated. Verify that the precision signal source is connected and ready. Allow a 30 minute warm-up period before calibrating the unit. Selecting `NO` at any calibration step, will cause the unit to maintain the existing calibration parameters for that step. Selecting `YES` and pressing the **P** key will cause the unit to store new calibration settings for the range selected. Pressing **D** at any time will exit programming mode, but any range that has been calibrated will maintain the new settings.

Input Calibration Procedure

- After entering `CODE 48`, in Factory Service Operations, select the input (`0020u` or `020u`) to be calibrated.
- Press the **P** key until the desired range along with `zEP` is indicated on Line 1 of the unit.
- Apply the zero input limit of the range indicated on Line 1 of the unit.
- Press $\overline{F1}$ to select `YES`.
- Press **P**. Display will indicate `----` on Line 2 as the unit reads and stores the new calibration parameter.
- Display will indicate the desired range along with `Full` on Line 1 of the unit.
- Apply the signal level indicated on Line 1 of the unit.
- Press $\overline{F1}$ to select `YES`.
- Press **P**. Display will indicate `----` on Line 2 as the unit reads and stores the new calibration parameter.
- Repeat Preparation and Calibration Procedure for the other Input Range if calibration for the other range is desired.

Analog Output Card Calibration

Before starting, verify that a precision meter with an accuracy of 0.05% or better (voltmeter for voltage output and/or current meter for current output) is connected and ready. Using the chart below, step through the five selections to be calibrated. At each prompt, use the $\overline{F1}$ and $\overline{F2}$ keys to adjust the output so that the external meter display matches the selection being calibrated. When the external reading matches, or if the range is not being calibrated, press the **P** key to advance to the next range. When all the desired ranges have been calibrated, exit programming mode and remove the external meters.

DISPLAY	EXTERNAL METER	ACTION
0.000A	0.00 mA	Adjust if necessary, press P
0.004A	4.00 mA	Adjust if necessary, press P
0.020A	20.00 mA	Adjust if necessary, press P
0.0u	0.00 V	Adjust if necessary, press P
10.0u	10.00 V	Adjust if necessary, press P

TROUBLESHOOTING

PROBLEM	REMEDIES
No Display At Power-Up	Check power level and power connections
No Display After Power-Up	Check Display Module: <i>d-L E U</i> , <i>d-C ont</i> , and <i>L I NE 1</i> program settings.
Program Locked-Out	Check for Active User Input, programmed for <i>PLUC</i> . Deactivate User Input. Enter proper access code at <i>[0 d E 0]</i> prompt. (Universal access code = <i>222</i>)
No Line 1 Display	Check program settings for Line 1 Display Value Select/Enable. Confirm at least one Line 1 Display Value is enabled (<i>Y E 5</i>).
No Line 2 Display	Check program settings for Line 2 Value Access. Confirm at least one Line 2 Parameter Value is enabled in Main Display Loop (<i>d-r E R d</i> , <i>d-r 5 t</i> , <i>d- E n t r</i>).
No Line 1 Units Mnemonic Display	Check program settings for Line 1 Units Mnemonic(s).
Display of <i>0 L 0 L</i> , <i>U L U L</i> , or “. . . .”	See General Meter Specifications, Display Messages.
Incorrect Input Display Value	Check Input Jumper Setting, Input Level, and Input Connections. Verify Input - Analog program settings. Contact factory
Modules or Parameters Not Accessible	Check for corresponding option card. Verify parameter is valid in regard to previous program settings.
Error Code: <i>E r r K E Y</i>	Keypad is active at power up. Check for depressed or stuck keypad. Press any key to clear Error Code.
Error Code: <i>E E P A r</i> Error Code: <i>E E P d n</i>	Parameter Data Checksum Error. Press any key to clear Error Code, verify all program settings and cycle power. Contact factory if Error Code returns at next power-up.
Error Code: <i>E r r P r a</i>	Parameter Data Validation Error. Press any key to clear Error Code, verify all program settings and cycle power. Contact factory if Error Code returns at next power-up.
Error Code: <i>E E [R L</i>	Calibration Data Validation Error. Contact factory.
Error Code: <i>E E L i n</i>	Linear Output Card Data Validation Error. Press any key to clear Error Code and cycle power. If Error Code returns at next power-up, replace Linear Option Card or contact factory.

PARAMETER VALUE CHART PAX2S

Programmer _____ Date _____
Unit# _____ Security Code _____

INPUT INPUT SETUP PARAMETERS

ANALOG Analog Input Parameters

DISPLAY	PARAMETER	USER SETTING
rRNGE	INPUT RANGE	_____
rPcE	INPUT UPDATE RATE	_____
dECPtE	DECIMAL RESOLUTION	_____
rOund	ROUNDING INCREMENT	_____
tArE	DISPLAY TARE (OFFSET)	_____
FILtEr	DIGITAL FILTER	_____
bAND	DIGITAL FILTER BAND	_____
POINtS	SCALING POINTS	_____
StYLE	SCALING STYLE	_____
iNPUt 1	INPUT 1 SCALING VALUE	_____
dISPLy 1	DISPLAY 1 VALUE	_____
iNPUt 2	INPUT 2 SCALING VALUE	_____
dISPLy 2	DISPLAY 2 VALUE	_____
iNPUt 3	INPUT 3 SCALING VALUE	_____
dISPLy 3	DISPLAY 3 VALUE	_____
iNPUt 4	INPUT 4 SCALING VALUE	_____
dISPLy 4	DISPLAY 4 VALUE	_____
iNPUt 5	INPUT 5 SCALING VALUE	_____
dISPLy 5	DISPLAY 5 VALUE	_____
iNPUt 6	INPUT 6 SCALING VALUE	_____
dISPLy 6	DISPLAY 6 VALUE	_____
iNPUt 7	INPUT 7 SCALING VALUE	_____
dISPLy 7	DISPLAY 7 VALUE	_____
iNPUt 8	INPUT 8 SCALING VALUE	_____
dISPLy 8	DISPLAY 8 VALUE	_____
iNPUt 9	INPUT 9 SCALING VALUE	_____

DISPLAY	PARAMETER	USER SETTING
dISPLy 9	DISPLAY 9 VALUE	_____
iNPUt 10	INPUT 10 SCALING VALUE	_____
dISPLy 10	DISPLAY 10 VALUE	_____
iNPUt 11	INPUT 11 SCALING VALUE	_____
dISPLy 11	DISPLAY 11 VALUE	_____
iNPUt 12	INPUT 12 SCALING VALUE	_____
dISPLy 12	DISPLAY 12 VALUE	_____
iNPUt 13	INPUT 13 SCALING VALUE	_____
dISPLy 13	DISPLAY 13 VALUE	_____
iNPUt 14	INPUT 14 SCALING VALUE	_____
dISPLy 14	DISPLAY 14 VALUE	_____
iNPUt 15	INPUT 15 SCALING VALUE	_____
dISPLy 15	DISPLAY 15 VALUE	_____
iNPUt 16	INPUT 16 SCALING VALUE	_____
dISPLy 16	DISPLAY 16 VALUE	_____

USER User Input Parameters

DISPLAY	PARAMETER	USER SETTING
USrAcE	USER ACTIVE STATE	_____
USr-1	USER INPUT 1	_____
USr-2	USER INPUT 2	_____
USr-3	USER INPUT 3	_____
F1	FUNCTION KEY 1	_____
F2	FUNCTION KEY 2	_____
SEC-F1	2nd FUNCTION KEY 1	_____
SEC-F2	2nd FUNCTION KEY 2	_____

OUTPUT OUTPUT PARAMETERS

SETPOINT Setpoint Output Parameters

DISPLAY	PARAMETER	USER SETTING	USER SETTING	USER SETTING	USER SETTING
		S1	S2	S3	S4
SELEct	SETPOINT SELECTION	_____	_____	_____	_____
ASSIGN	SETPOINT SOURCE	_____	_____	_____	_____
AcT: ON	ACTION FOR SETPOINT	_____	_____	_____	_____
SEtPnt	SETPOINT VALUE	_____	_____	_____	_____
bn-dEV	SETPOINT BAND/DEVIATION VALUE	_____	_____	_____	_____
HYSter	HYSTERESIS FOR SETPOINT	_____	_____	_____	_____
t-ON	ON TIME DELAY SETPOINT	_____	_____	_____	_____
t-OFF	OFF TIME DELAY SETPOINT	_____	_____	_____	_____
LOGic	OUTPUT LOGIC	_____	_____	_____	_____
rESEt	RESET ACTION	_____	_____	_____	_____
Stndby	STANDYBY OPERATION	_____	_____	_____	_____
Annun	OUTPUT ANNUNCIATOR LIGHT	_____	_____	_____	_____
CoLor	CHANGE COLOR	_____	_____	_____	_____

ANALOG Analog Output Parameters

DISPLAY	PARAMETER	USER SETTING
tYPE	ANALOG TYPE	_____
ASSIGN	ANALOG ASSIGNMENT	_____
ANALOG L ^O	ANALOG LOW	_____
ANALOG H ^I	ANALOG HIGH	_____
UPdAtE	ANALOG UPDATE TIME	_____

dISPLy DISPLAY PARAMETERS

LINE 1	PARAMETER	USER SETTING
CoLor	Line 1 Display Color	_____
d-LEv	Display Level	_____
d-Contr	Display Contrast Level	_____
SELEct	Line 1 Display Value Select	_____
iNPUt	_____	L0 _____
GrOSS	_____	S1 _____
tArE	_____	S2 _____
tDEAL	_____	S3 _____
H	_____	S4 _____

DISPLAY	PARAMETER	USER SETTING
Scroll	Line 1 Display Scroll Enable/Time	_____
Units	Line 1 Units Mnemonic(s)	_____
	LABEL MNEMONIC	LABEL
		List A List B
Unit 1	Line 1 Units Digit 1 (Left)	_____
Unit 2	Line 1 Units Digit 2 (Center)	_____
Unit 3	Line 1 Units Digit 3 (Right)	_____

LIST A CUSTOM MNEMONICS	Unit 1	Unit 2	Unit 3
Input	_____	_____	_____
Gross	_____	_____	_____
Tare	_____	_____	_____
Total	_____	_____	_____
Max (HI)	_____	_____	_____
Min (LO)	_____	_____	_____

LIST B CUSTOM MNEMONICS	Unit 1	Unit 2	Unit 3
Input	_____	_____	_____
Gross	_____	_____	_____
Tare	_____	_____	_____
Total	_____	_____	_____
Max (HI)	_____	_____	_____
Min (LO)	_____	_____	_____

LINE 2 Line 2 Parameters

ACCESS	LINE 2 VALUE ACCESS	USER SETTING
INPUT	_____	S2 _____
GROSS	_____	b2-d2 _____
TARE	_____	S3 _____
TOTAL	_____	b3-d3 _____
HI	_____	S4 _____
LO	_____	b4-d4 _____
LIST	_____	Co lor _____
SI	_____	d-LEU _____
bl-dl	_____	d-Cont _____

FUNCTION	LINE 2 FUNCTIONS ACCESS	USER SETTING
REL	_____	r-2 _____
r-tARE	_____	r-3 _____
bAL	_____	r-4 _____
r-tot	_____	r-34 _____
r-HI	_____	r-234 _____
r-LO	_____	r-ALL _____
r-HL	_____	Pr int _____
r-1	_____	_____

DISPLAY	PARAMETER	USER SETTING
Scroll	Line 2 Display Scroll Enable/Time	_____
Units	Line 2 Units Mnemonic(s)	_____
	LABEL MNEMONIC	LABEL
		List A List B
Unit 1	Line 2 Units Digit 1 (Left)	_____
Unit 2	Line 2 Units Digit 2	_____
Unit 3	Line 2 Units Digit 3	_____
Unit 4	Line 2 Units Digit 4	_____
Unit 5	Line 2 Units Digit 5	_____
Unit 6	Line 2 Units Digit 6	_____
Unit 7	Line 2 Units Digit 7	_____
Unit 8	Line 2 Units Digit 8	_____
Unit 9	Line 2 Units Digit 9 (Right)	_____

LIST A CUSTOM MNEMONICS	1	2	3	4	5	6	7	8	9
Input	_____	_____	_____	_____	_____	_____	_____	_____	_____
Gross	_____	_____	_____	_____	_____	_____	_____	_____	_____
Tare	_____	_____	_____	_____	_____	_____	_____	_____	_____
Total	_____	_____	_____	_____	_____	_____	_____	_____	_____
HI (Max)	_____	_____	_____	_____	_____	_____	_____	_____	_____
LO (Min)	_____	_____	_____	_____	_____	_____	_____	_____	_____

LIST B CUSTOM MNEMONICS	1	2	3	4	5	6	7	8	9
Input	_____	_____	_____	_____	_____	_____	_____	_____	_____
Gross	_____	_____	_____	_____	_____	_____	_____	_____	_____
Tare	_____	_____	_____	_____	_____	_____	_____	_____	_____
Total	_____	_____	_____	_____	_____	_____	_____	_____	_____
HI (Max)	_____	_____	_____	_____	_____	_____	_____	_____	_____
LO (Min)	_____	_____	_____	_____	_____	_____	_____	_____	_____

CODE Security Code _____

Secondary Function Parameters

DISPLAY	PARAMETER	USER SETTING
HI-ASN	MAX ASSIGNMENT	_____
HI-t	MAX CAPTURE DELAY TIME	_____
LO-ASN	MIN ASSIGNMENT	_____
LO-t	MIN CAPTURE DELAY TIME	_____
dSP-t	DISPLAY UPDATE TIME	_____
RL-t	AUTO-ZERO TRACKING TIME	_____
RL-bnd	AUTO-ZERO TRACKING BAND	_____

TOTAL Totalizer Parameters

DISPLAY	PARAMETER	USER SETTING
dECPtE	TOTALIZER DECIMAL POINT	_____
t bPSE	TOTALIZER TIME BASE	_____
SCALE	TOTALIZER SCALE FACTOR	_____
LO Cut	TOTALIZER LOW CUT VALUE	_____
PowerUP	TOTALIZER POWER-UP RESET	_____

Port COMMS. PORT PARAMETERS

DISPLAY	PARAMETER	USER SETTING
USB	USB Port Parameters	
CONF16	USB Configuration	_____
SERIAL	Serial Port Parameters	
TYPE	Communications Type	_____
BAUD	Baud Rate	_____
DATA	Data Bits	_____
PARITY	Parity Bit	_____
ADDR	Unit Address	_____
DELAY	Transmit Delay	_____
ABRU	Abbreviated Printing	_____
OPT	Print Options	_____
INPUT	Signal Input (relative)	_____
GROSS	Gross (absolute)	_____
TARE	Tare Value	_____
TOTAL	Total Value	_____
HI	Maximum Value	_____
LO	Minimum Value	_____
SETPtE	Setpoint Values	_____

RED LION CONTROLS TECHNICAL SUPPORT

If for any reason you have trouble operating, connecting, or simply have questions concerning your new product, contact Red Lion's technical support.

Support: support.redlion.net
 Website: www.redlion.net
 Inside US: +1 (877) 432-9908
 Outside US: +1 (717) 767-6511

Red Lion Controls, Inc.
 35 Willow Springs Circle, York, PA 17406

This page intentionally left blank.

PAX2S PROGRAMMING QUICK OVERVIEW

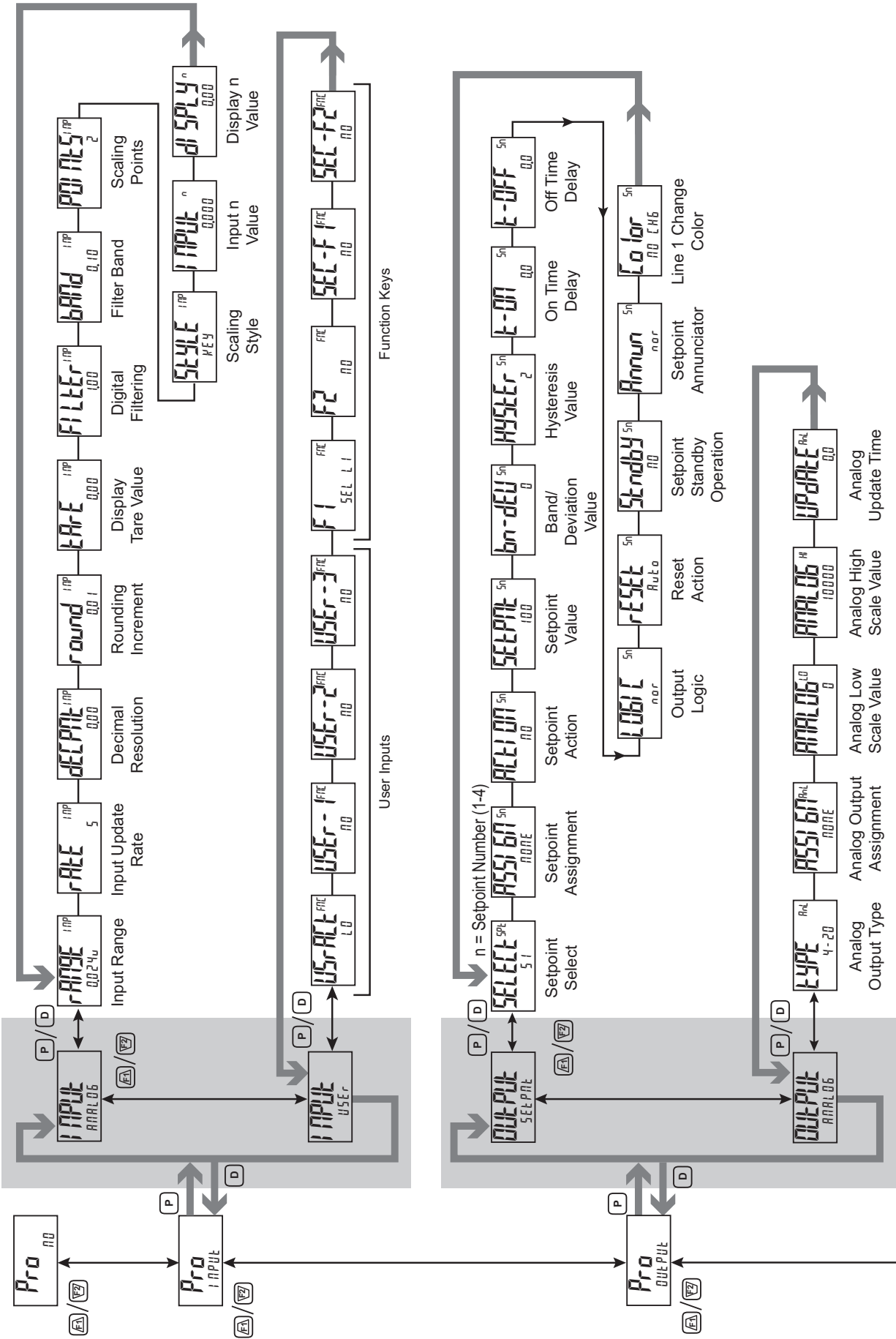

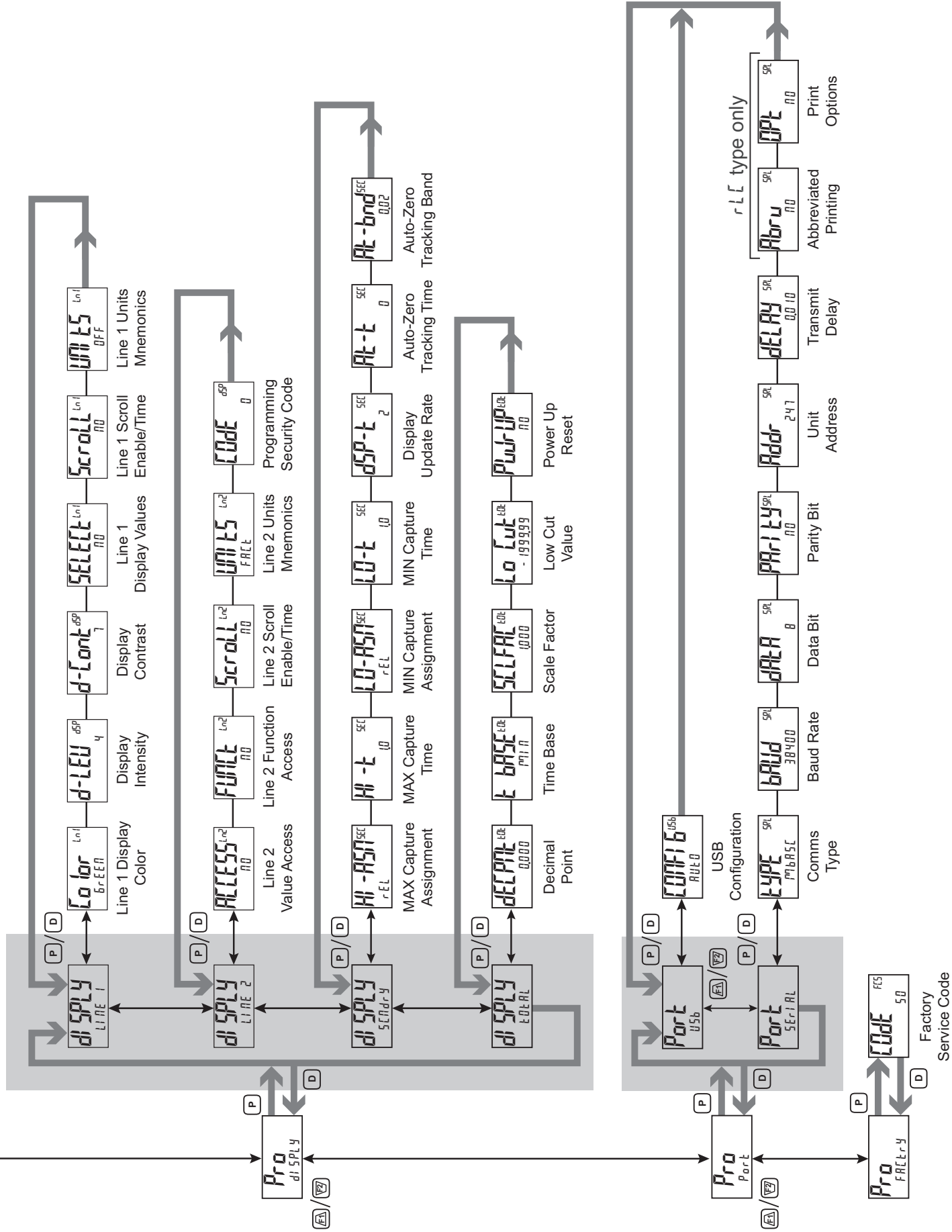

COPYRIGHT

©2023 Red Lion Controls, Inc. All rights reserved. Red Lion and the Red Lion logo are registered trademarks of Red Lion Controls, Inc. All other company and product names are trademarks of their respective owners.

LIMITED WARRANTY

(a) Red Lion Controls Inc. (the "Company") warrants that all Products shall be free from defects in material and workmanship under normal use for the period of time provided in "Statement of Warranty Periods" (available at www.redlion.net) current at the time of shipment of the Products (the "Warranty Period"). **EXCEPT FOR THE ABOVE-STATED WARRANTY, COMPANY MAKES NO WARRANTY WHATSOEVER WITH RESPECT TO THE PRODUCTS, INCLUDING ANY (A) WARRANTY OF MERCHANTABILITY; (B) WARRANTY OF FITNESS FOR A PARTICULAR PURPOSE; OR (C) WARRANTY AGAINST INFRINGEMENT OF INTELLECTUAL PROPERTY RIGHTS OF A THIRD PARTY; WHETHER EXPRESS OR IMPLIED BY LAW, COURSE OF DEALING, COURSE OF PERFORMANCE, USAGE OF TRADE OR OTHERWISE.** Customer shall be responsible for determining that a Product is suitable for Customer's use and that such use complies with any applicable local, state or federal law.

(b) The Company shall not be liable for a breach of the warranty set forth in paragraph (a) if (i) the defect is a result of Customer's failure to store, install, commission or maintain the Product according to specifications; (ii) Customer alters or repairs such Product without the prior written consent of Company.

(c) Subject to paragraph (b), with respect to any such Product during the Warranty Period, Company shall, in its sole discretion, either (i) repair or replace the Product; or (ii) credit or refund the price of Product provided that, if Company so requests, Customer shall, at Company's expense, return such Product to Company.

(d) **THE REMEDIES SET FORTH IN PARAGRAPH (c) SHALL BE THE CUSTOMER'S SOLE AND EXCLUSIVE REMEDY AND COMPANY'S ENTIRE LIABILITY FOR ANY BREACH OF THE LIMITED WARRANTY SET FORTH IN PARAGRAPH (a).**

BY INSTALLING THIS PRODUCT, YOU AGREE TO THE TERMS OF THIS WARRANTY, AS WELL AS ALL OTHER DISCLAIMERS AND WARRANTIES IN THIS DOCUMENT.