

MODEL SCP - 100 KHZ PRESETTABLE COUNTER WITHOUT DISPLAY - ECONOMY PLUS THESE HIGH PERFORMANCE FEATURES:



- TWO ADJUSTABLE OUTPUT TIME DELAY RANGES
 1. 0.05 to 1 sec for conventional preset use
 2. 0.7 to 15 msec for dividing pre-scaler use
- L.E.D. STATUS INDICATORS FOR:
 Count Activity; Preset Output; Reset
- AVAILABLE IN 4 or 6-DIGIT VERSIONS
- COUNT INPUT PROGRAMMABLE FOR ALL STANDARD SENSORS & FOR COUNT SWITCHES
- RESET ON POWER-UP
- TWO COMPLEMENTARY SOLID-STATE OUTPUTS
 1. Primary output to drive control relay
 2. Auxiliary output (inverted) for external circuitry
- RESET-TO-ZERO (RTZ) ACTION WITH FIVE SELECTABLE RESET MODES
 1. Manual Reset - Timed Output
 2. Manual Reset - Latched Output
 3. Automatic Cycle Reset & Run at Preset
 4. Automatic Cycle Reset & Run at end of Timeout
 5. Automatic Cycle - Prescale Divider
- CONTROL INPUTS FOR:
 1. Remote Reset
 2. Count Inhibit
 3. Up/Down Count Direction

DESCRIPTION

The Model SCP is an economical and reliable answer to a wide variety of machine control, batching and pre-scale dividing applications. With dual complementary outputs, count input configuration set-up switches to accept almost any sensor output, five reset cycle modes, and control inputs for remote reset, up/down counting, and inhibit functions, the SCP offers extremely broad application flexibility. Based on solid-state technology proven in tens of thousands of field applications, this unit features outstanding reliability and noise immunity.

In operation, the desired preset count is dialed in by means of digital thumbwheel switches on the front panel. The number entered on the switches is loaded into an internal comparator when the counter is reset to 0, or at the end of a count cycle, and can not be changed once the count has started. This avoids the problem of an operator inadvertently changing a thumbwheel switch position once a run has started, or accidental overrun which can occur with a counter that may be set "on-the-fly".

The front panel also contains three LED lights to indicate status of the counter. A "count" light illuminates whenever the count signal is high. At slow count rates, individual counts can be observed by the blinking of this light, and at higher count rates, the light blinks merge into a continuous glow. A "preset" light signals that the preset count has been reached. The "reset" indicator lights and stays on as long as the reset condition exists.

Connections are made to the Model SCP via a terminal strip at the rear. Clamp-Type pressure plate terminals accept stripped #14 wire without lugs. (Tinning of stranded wire is recommended for easy installation.)

SPECIFICATIONS

1. **PRIMARY SUPPLY VOLTAGE:** Available in two voltage ranges. 115/230 VAC ($\pm 10\%$), 50/60 Hz, 4 VA. Also operates from +12 VDC Supply (See Application Notes).
2. ***SENSOR OUTPUT POWER (TERM. "A"):**
 +12 VDC $\pm 15\%$ @ 50 mA max.
3. **RESET & PRESET TIMING PARAMETERS:**
 - A. **COUNT-AFTER-RESET** - Counter will accept new counts 7.5 μ sec after reset is removed.
 - B. New preset value entry takes place during reset or during timed output. If a new preset value is entered after a count cycle has started, the original preset value remains in effect for that cycle. The new value will be loaded in at the end of the cycle and will be in effect for the next cycle.
4. **OUTPUTS:**
 - SNK OUT** - Primary output (*current sinking*) to drive control relay load, 100 mA max. Output turns "ON" (*goes low*) when preset count is reached.
 - SRC OUT** - Aux. Output (*inverted*) delivers +12 VDC @ +10 mA when preset count is reached.
5. **CURRENT DRAIN FROM BATTERY BACKUP:** 60 mA without sensor and relay output load. (See Accessories Section of Catalog for Non-Interruptible Power Supplies)
6. **OPERATING TEMPERATURE RANGE:** -20° to +50°C
7. **CONSTRUCTION:** Steel Case, Aluminum Bezel and Panel, Black Epoxy Coated.
8. **WEIGHT:** 1.2 lbs. (0.54 Kg)

* - See SC Series Sensor Input Connections & Input Configuration Switch Set-up, Note 1.

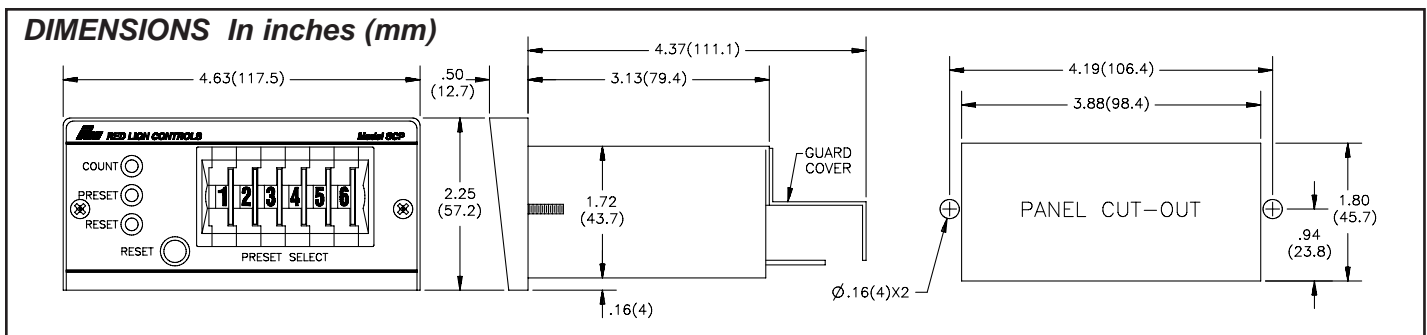

MODEL SCP INPUT/OUTPUT CONNECTIONS & PROGRAMMING SWITCHES

RESET MODE & CYCLE SWITCHES

- S4 - ON:** ENABLES Front Panel Reset Button
OFF: DISABLES Front Panel Reset
- S5 - ON:** AUTO RST* - Causes counter to automatically reset either upon reaching the preset count or after time-out of output as determined by S6.
OFF: MAN. - Counter will reset only in response to Front Panel Button (if ENABLED) or Remote Reset (\bar{R}).
- S6 - ON:** T.D. RST* - Causes counter to reset automatically (with S5 ON) at end of output time delay.
OFF: INST* - Causes counter to reset automatically (with S5 ON) at instant preset count is reached.
- S7 - ON:** LATCH - causes outputs to latch after reaching preset. Outputs stay ON until manually reset by Front Panel Button or Remote Reset.
- OFF:** T.D. - Allows outputs to respond to normal time delayed dropout.
- S8 - ON:** LG. DLY. - Sets adjustable Time Delay Range to 0.05 - 1 sec.
OFF: SHT. - Sets adjustable Time Delay to 0.7 - 15 msec.

* Remote Reset (\bar{R}) and Front Panel Reset (if ENABLED) will always reset the counter regardless of automatic setup mode used.

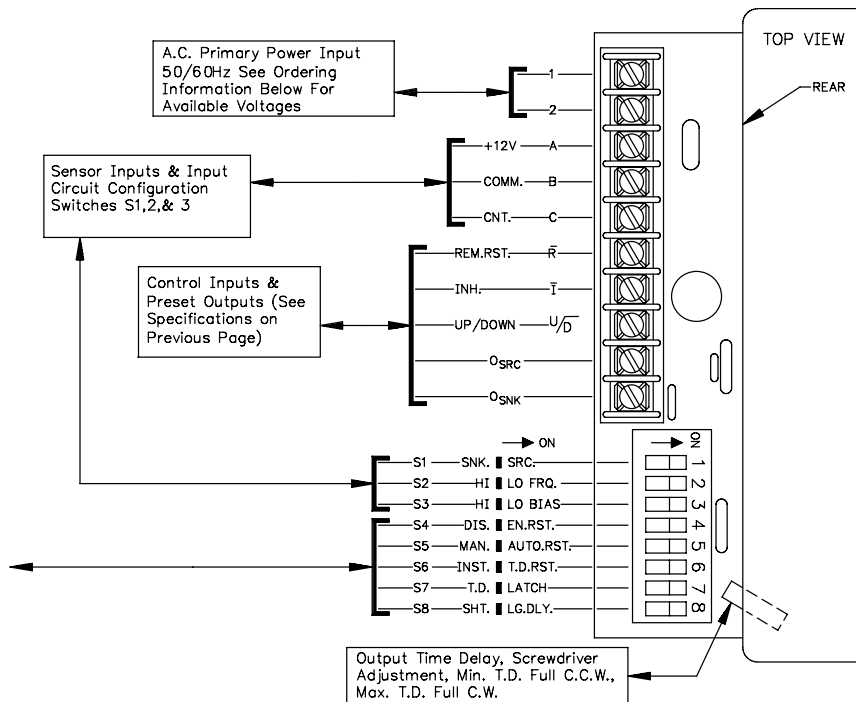

TYPICAL APPLICATION CONNECTIONS & SET-UP

A typical length-measuring wind/rewind application involving up/down counting to accommodate forward and reverse web motion and provision for remote reset.

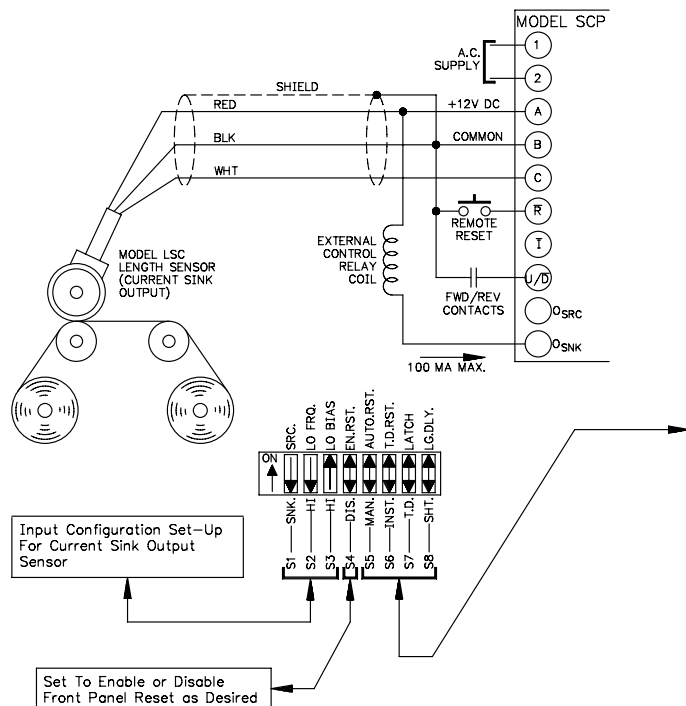

RESET CYCLE MODES - SWITCHES S5, 6, 7 & 8

MODE 1 LATCH AT PRESET, MANUAL RESET

Counts from zero, activates and latches outputs ON at preset. Front panel button (if enabled) or remote reset (Term. " \bar{R} ") returns counter to zero and deactivates outputs. Accepts new count pulses 7.5 μ sec after reset is removed.



MODE 2 MOMENTARY OUTPUT AT PRESET, MANUAL RESET

Counts from zero and activates outputs momentarily at preset. Momentary output time is adjustable from 0.05 to 1 second. Count can proceed upward if not reset, and if count direction is then reversed, by pulling U/D down to B, the outputs will again reactivate as the count decrements down through preset a second time. Output activates each time count passes through preset provided time-out from previous pass has concluded. Front panel reset (if enabled) or remote reset (\bar{R}) returns the counter to zero and interrupts output if time-out has not concluded. Unit is ready to accept new counts 7.5 μ sec after removal of reset.



MODE 3 AUTOMATIC CYCLE - RESET & RUN AT PRESET

Counts from zero, activates outputs momentarily at preset and simultaneously resets counter to zero, ready to accept new counts for next cycle 7.5 μ sec after resetting. Momentary output time is adjustable from 0.05 to 1 sec. Output ON-time must be less than time required to count from zero to reset for proper Mode 3 operation.



MODE 4 AUTO. CYCLE - RESET & RUN AFTER TIME-OUT

Counts from zero, activates outputs momentarily at preset. Counter resets to zero at conclusion of output time-out and is ready to accept new counts for the next cycle 7.5 μ sec after reset.



MODE 5 AUTO. CYCLE - PRESCALE DIVIDER

Identical to Mode 3 except momentary output time delay range switched to "short" range (0.7 to 15 msec) by placing S8 in OFF position. The shorter time-out allows the SCP to be used as a pre-scaling divider providing output pulses in excess of 1 KHz to the input of another counter.



ORDERING INFORMATION

MODEL NO.	DESCRIPTION	NO. OF DIGITS	PART NUMBERS FOR AVAILABLE SUPPLY VOLTAGES	
			230 VAC	115 VAC
SCP	100 KHz Preset Counter w/o Display	4	SCP00411	SCP00401
		6	SCP00611	SCP00601

For more information on Pricing, Enclosures & Panel Mount Kits see the RLC Catalog or contact your local RLC distributor.

SCP CONTROL INPUT/OUTPUT CONNECTIONS

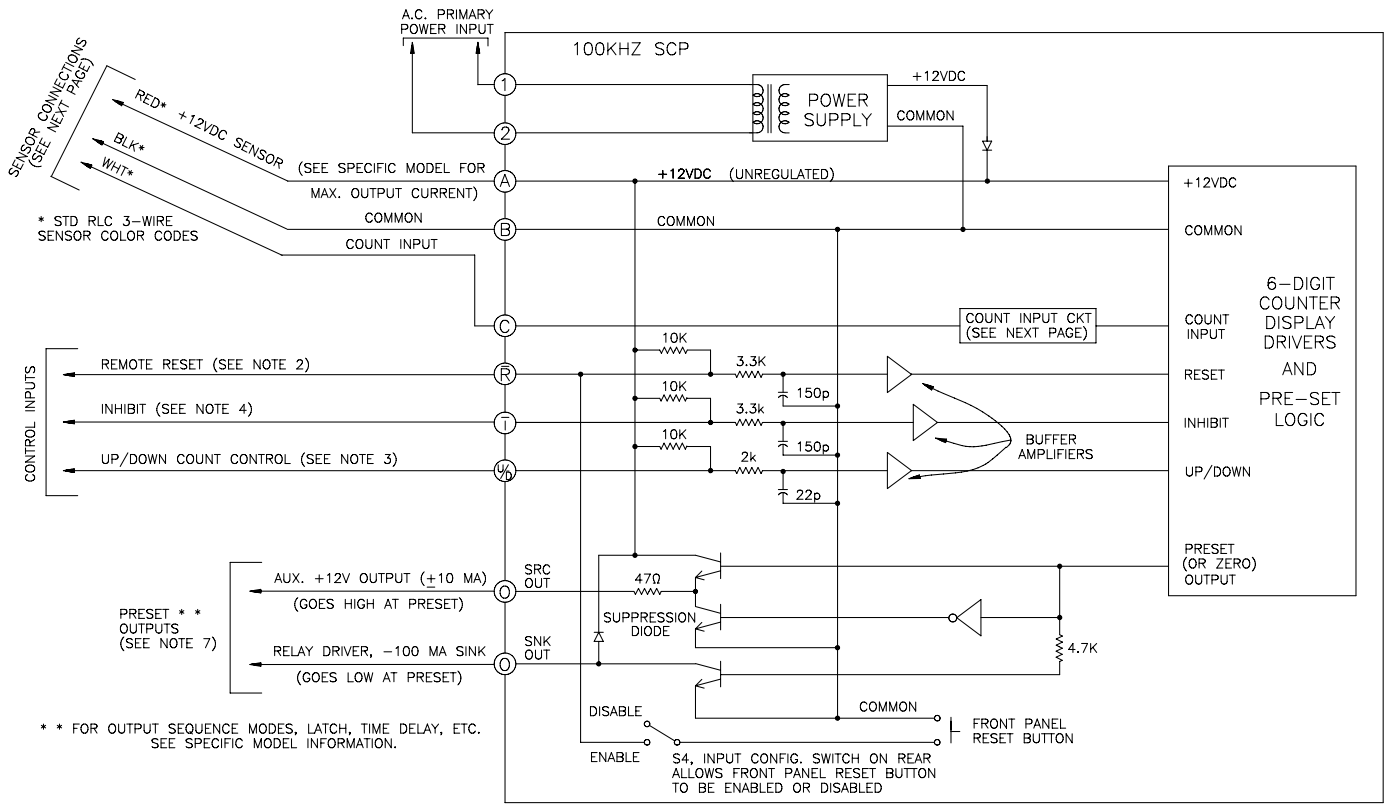

NOTES:

1. BATTERY BACK-UP & DISPLAY LIGHT (L)

OPERATION

SC Counters can be operated from +12 VDC batteries or power supplies. (+12 VDC is connected to Term. "A" and minus to "B").

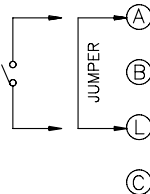

2. REMOTE RESET (R̄) - Counter will be reset when this input is pulled low (to Term. "B") by a remote contact or NPN O.C. output. Response time to Reset input is 2 µsec. Counter is ready to accept new counts 7.5 µsec after removal of reset. (Front panel reset button on all Models may be enabled or disabled via configuration switch on rear.)

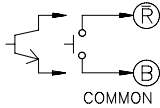

3. UP/DOWN (U/D̄) - With U/D̄ Terminal open, counters increment (count "UP") to increase the accumulated number. When U/D̄ is pulled low, the counter will decrement (count "DOWN") to decrease the accumulated number. Response time to change count direction is 2 µsec.

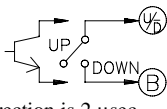

Note: SC Counters count in complementary numbers when counting down through zero, i.e. the counting sequence when decrementing is 3, 2, 1, 0, 999999, 999998, 999997, etc.

4. INHIBIT (Ī) - Counter is inhibited from accepting counts as long as "Ī" is pulled low to Term. "B". Response time for initiation is 2 µsec, and release is 4 µsec.

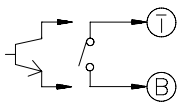

5. OUTPUTS (Preset Counters) - All SC Presettable counters have 2 complementary outputs per preset level (Models SC2DU and SC2DD have two sets of outputs, one set for each preset level).

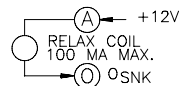

SNK OUT - Primary output for driving a relay coil. Output goes low to energize relay at end of count cycle. This output is rated $V_{OL} = 0.6 V @ 100 mA$, $V_{OH} = 12 V$ max. (Internal suppression diode limits V_{OH} to +12 V internal supply and higher external supply cannot be used.)

SRC OUT - Auxiliary output goes high at end of a count cycle. This output is actually Bi-Polar, will source or sink 10 mA, and may be used for count input to other counters or external electronic control circuits.

6. RESET-TO-PRESET (RTP) & RESET-TO-ZERO (RTZ) ACTION

SC Presettable Counters when Reset, return the counter either to zero or to the Preset value (Start Count) as determined by the Reset Action.

MODEL SCP - Fixed RTZ action

MODEL SCD - Programmable for RTZ or RTP action

MODEL SC2DU - Fixed RTZ action

MODEL SC2DD - Fixed RTP action

Reset actions do not determine UP/DOWN count direction. Count direction is controlled only by the U/D̄ terminal which must be connected to "B" when down-counting is required.

SENSOR INPUT CONNECTIONS & INPUT CONFIGURATION SWITCH SET-UP

The schematic diagram at right shows the details of the 100 KHz SCP count input circuit, the terminals used for sensor connection and the configuration set-up switches. These switches are the first three switches in the switch bank and are designated S1, S2 and S3 from left to right. The functions of these switches are as follows:

- S1 - ON (SRC):** Provides 3.9 KΩ Pull-down load for sensors with sourcing outputs. (Max. sensor current, 3 mA)
OFF (SNK): Provides a 7.8 KΩ Pull-up load for sensors with sinking outputs. (Max. sensor current, 1.6 mA)
- S2 - ON (LO FRQ):** Connects damping cap for switch contact debounce. Limits count speed to 100 cps maximum. Min. count pulse ON/OFF times-5 msec. (See Note 2)
OFF (HI FRQ): Removes damping cap, allows operation to 100 KHz. Min count pulse ON/OFF times-5 μsec.
- S3 - ON (LO BIAS):** Sets input trigger levels to the low range to accept logic pulses with 0 to +5 V swings. ($V_{IL} = 1.5 V$, $V_{IH} = 3.75 V$, See Note 3)
OFF (HI BIAS): Sets input trigger levels at mid-range to accept outputs from 2-wire proximity sensors, resistive photo-cells and logic pulses with full 0 to +12 V swings. ($V_{IL} = 5.5 V$, $V_{IH} = 7.5 V$, See Note 3)

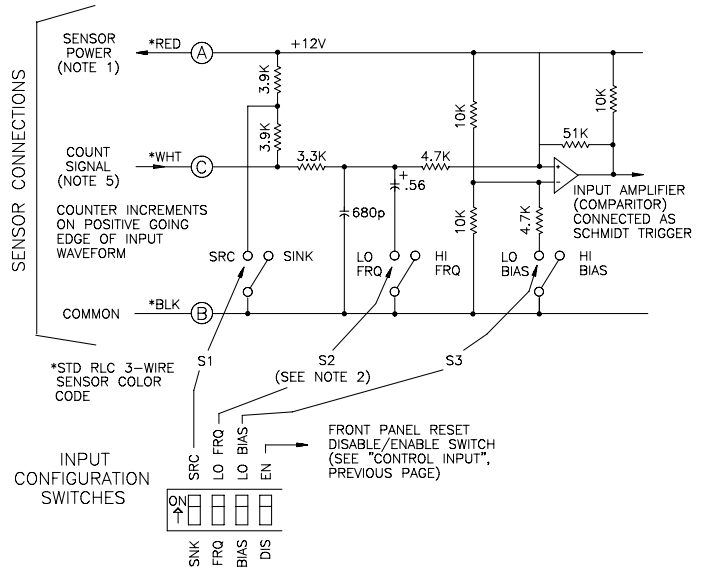

<p>COUNT SWITCH OR ISOLATED TRANSISTOR OUTPUTS</p> <p>CURRENT SOURCE CONNECTED (INCREMENT ON CLOSING)</p> <p>CURRENT SINK CONNECTED (INCREMENT ON OPENING)</p> <p>FOR INPUT VOLTAGES ABOVE +12V, SEE NOTE 5</p> <p>RLC SENSOR MODELS: MPS, RR & PR PHOTO ELECTRICS</p>	<p>SENSORS WITH CURRENT SINK OUTPUT (NPN O.C.)</p> <p>(INCREMENTS ON TURN-OFF)</p> <p>RLC SENSOR MODELS: LMP-C, ASTC, PSAC, RPGC, RRGB, RPHG, LSC</p> <p>CONNECTOR PIN DESIGNATOR FOR RRGB & RPHG</p>	<p>SENSORS WITH CURRENT SOURCE OUTPUT (PNP O.C.)</p> <p>(INCREMENTS ON TURN-ON)</p>		
<p>TWO WIRE PROXIMITY SENSORS CURRENT SOURCE CONNECTED</p> <p>(INCREMENT ON CURRENT RISE)</p> <p>RLC SENSOR MODELS: PSA-1, PSA-2</p>	<p>OLDER STYLE SENSORS WITH -EF OUTPUT, CURRENT SOURCE CONNECTED</p> <p>(INCREMENT ON + EDGE)</p> <p>SENSOR WITH +5V EMITTER-FOLLOWER OUTPUT</p> <p>RLC SENSOR MODELS: LMP-EC, 715</p>	<p>A.C. INPUTS FROM MAG PICKUPS, TACH. GENERATORS, INVERTERS, ETC.</p> <p>AC SIGNAL SOURCE</p> <p>RESISTOR TO LIMIT CURRENT (SEE NOTE 5)</p> <p>A.C. SIGNALS OVER 50 VAC, RMS SHOULD BE COUPLED THROUGH AN ISOLATION TRANSFORMER</p>	<p>INTERFACING WITH CMOS CIRCUITRY (B TYPE)</p> <p>NOTE: IF EXTERNAL SUPPLY IS USED TO POWER CMOS CIRCUIT, VOLTAGE MUST BE EQUAL TO OR GREATER THAN TERM. A VOLTAGE.</p>	<p>INTERFACING WITH TTL</p> <p>NOTE: CIRCUIT SHOWN FOR STANDARD TTL GATE OUTPUT. TTL CIRCUITS ARE AVAILABLE WITH NPN O.C. OUTPUT ELIMINATING NEED FOR THE CLAMP DIODE.</p>

NOTES:

1. SENSOR SUPPLY VOLTAGE AND CURRENT

Sensor supply voltage on Term. "A" is +12 VDC nominal with ±15% variation due to line and internal load variation. All RLC sensors will accommodate this variation. Maximum sensor current rating varies depending on the specific counter model (See Specifications of specific model). This rating is the maximum allowable sensor current when all digits of a 6-digit unit display 8's, and with 100 mA relay load(s) on preset counters. If all 6 digits are not used, an additional 45 mA is available for each digit not displayed. 4-digit models will deliver an additional 90 mA over the current rating stated. SC counter power supplies are not regulated, and in multiple counter (or counter/tachometer) installations all terminal "A's" and "B's" can be paralleled for load sharing. For unusually high sensor current requirements, use Accessory Power Supply (See Accessory Section of Catalog).

2. HI/LO FRQ. SELECTION

The HI/LO FRQ Selection switch MUST be set on LO FRQ when switch contacts are used to generate count input signals. Since the LO FRQ mode

also provides very high immunity against electrical noise pickup, it is recommended that this mode also be used whenever possible with electronic sensor outputs, as added insurance. The LO FRQ mode can be used with any type of sensor output provided count pulses never decrease below 5 msec, and the count rate does not exceed 100 cps.

3. V_{IL} and V_{IH} levels given are nominal values ±10% when counter voltage on terminal A is +12 VDC. These nominal values will vary in proportion to the variations in Terminal A voltage caused by line voltage and load changes.
4. When shielded cable is used, shield should be connected to terminal B at counter and left unconnected at sensor end.
5. The Count Input (Terminal C), can accept source pulses from other circuits up to +28 V in amplitude. For voltages above +28 V a limiting resistor and zener diode should be used to limit the voltage at Terminal C. Negative input voltages to Count Input (Terminal C), will damage the input circuit. If the possibility exists that the input voltage can swing negative, an external shunt or series diode should be used to block the negative swing.